

Original Teile Genuine Parts Original Teile Genuine Parts Original Teile Genuine Parts Original Teile Genuine Parts



Genuine Parts Original Teile Genuine Parts Original Teile Genuine Parts Original Teile Genuine Parts Original Teile

Superbeetles.nl

VW 1302/1303

VWkever.com

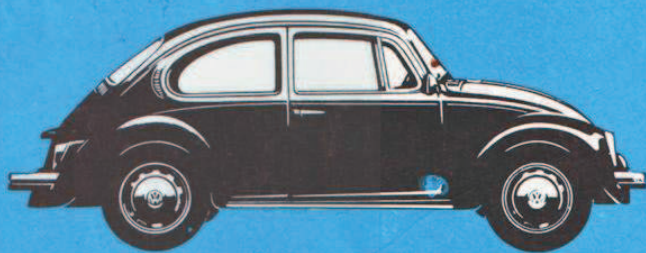

Bildkatalog für Original Volkswagen und Audi Teile.
Illustrated catalogue of Genuine Volkswagen and Audi Parts.
Catalogue illustré pour pièces Volkswagen et Audi d'Origine.
Catalogo illustrato delle parti originali Volkswagen e Audi.
Catálogo ilustrado de piezas originales Volkswagen y Audi.
Geïlustreerde catalogus voor Originele Volkswagen en Audi delen.

1984

Bildtafel-Übersicht Typ 1302/1303

Illustrations Type 1302/1303

Tableau des planches Type 1302/1303

Quadro sinottico illustrazioni Tipo 1302/1303

Ilustración-Cuadro sinóptico Tipo 1302/1303

Overzicht tekeningen type 1302/1303

Bildtafel-Nr.
Illustration No.
Planche-No.
Ilustraz.-N.
Ilustrac.-Num.
Tekening nr.

	Motor	Engine	Moteur	Motore	Motor	Motor
1	Motor	Engine	Moteur	Motore	Motor	Motor
2	Kurbelgehäuse, Befestigungsteile für Motor an Getriebe	Crankcase, Engine to transmission securing parts	Carter, Pièces d'assemblage des carters de moteur et de boîte-pont	Basamento, Organi di collegamento del motore con la trasmissione	Cárter del motor, Piezas para fijar el motor al cambio de velocidades	carter, bevestigingsdelen motor en versnellingsbak
3	Zylinder, Zylinderkopf mit Deckel	Cylinders, Cylinder head with cover	Cylindres, culasse avec couvercle	Cilindri, testata con coperchio	Cilindros, culata con tapa	cilinders, cilinderkop met deksel
4	Kurbelwelle, Pleuelstange, Lagerung, Riemenscheibe	Crankshaft, Connecting rods, Crankshaft bearings, Pulley	Vilebrequin bielles, coussinets, poulie	Albero a gomiti, bielle, cuscinetti, puleggia	Cigüeñal, bielas, cojinetes, polea	krukas, drijfstan- gen, lagers, poelie
5	Kolben, Kolbenringe, Kolbenbolzen	Pistons, Piston rings, Piston pin	Piston, segments, axe de piston	Pistone, segmenti, spinotto	Pistones, segmentos de pistón, bulón de pistón	zuigers, zuiger- veren, zuiger- pennen
6	Nockenwelle, Ventile	Camshaft, Valves	Arbre à cames, soupapes	Albero della distribuzione, valvole	Arbol de levas, válvulas	nokkenas, kleppen
7	Ölpumpe, Doppelölpumpe, Ölsieb, Ölüberdruckventil	Oil pump, Dual oil pump, Oil strainer, Oil pressure relief valve	Pompe à huile, double pompe à huile, tamis d'huile, limiteur de pression	Pompa olio, pompa doppia olio, filtro olio, valvola regolazione olio	Bomba de aceite, bomba de aceite doble, colador de aceite, válvula de sobrepresión de aceite	oliepomp, dubbele oliepomp, oliezeef, oliedrukventiel
8	Öleinfüllung, Ölmeßstab	Oil filler, Oil level dipstick	Remplissage d'huile, jauge de niveau d'huile	Tappo introduzione olio, astina livello olio	Relleno de aceite, varilla del nivel de aceite	olievulpijp, oliepijlstok
9	Ölkühler	Oil cooler	Radiateur d'huile	Radiatore dell'olio	Radiador de aceite	oliekoeler
10	Luftkühlung	Air cooling	Refroidissement par air	Raffreddamento ad aria	Refrigeración por aire	luchtkoeling
11	Kühlluftregelung	Cooling air control	Réglage du refroidissement	Valvole parziali- lizzatrici	Regulación del aire de refrigeración	koelluchtregeling
12	Motorabdeck- bleche	Engine cover plates	Blindages de moteur	Schermo motore	Chapas cubierta de motor	motorafdekplaten
13	Kraftstoffpumpe	Fuel pump	Pompe à essence	Pompa di alimentazione	Bomba de gasolina	benzinepomp
14	Kraftstoff- leitungen	Fuel lines	Canalisations d'alimentation	Tubazioni di alimentazione	Tuberías de gasolina	benzineleidingen
15	Vergaser 25, 30 PS	Carburetor 25, 30 bhp	Carbureteur 25, 30 CV	Carburatore 25, 30 CV	Carburador 25, 30 CV	carbureteur 25, 30 pk
16	Vergaser-Ober- teil 34-, 37-, 40-, 44-, 46-, 47-, 48-, 50 PS	Body upper for carburetor 34, 37, 40, 44, 46, 47, 48, 50 bhp	Corps supérieur pour carburateur 34-, 37-, 40-, 44-, 46-, 47-, 48-, 50 CV	Corpo superiore per carburatore 34-, 37-, 40-, 44-, 46-, 47-, 48-, 50 CV	Cuerpo sup. de carburador 34-, 37-, 40-, 44-, 46-, 47-, 48-, 50 CV	carbureteur- bovenstuk 34, 37, 40, 44, 46, 47, 48, 50 pk
17-10 17-20	Vergaser-Unter- teil 34-, 37-, 40-, 44-, 46-, 47-, 48-, 50 PS	Main body for carburetor 34, 37, 40, 44, 46, 47, 48, 50 bhp	Corps inférieur pour carburateur 34-, 37-, 40-, 44-, 46-, 47-, 48-, 50 CV	Corpo inferiore per carburatore 34-, 37-, 40-, 44-, 46-, 47-, 48-, 50 CV	Cuerpo inf. de carburador 34-, 37-, 40-, 44-, 46-, 47-, 48-, 50 CV	carbureteur- onderstuk 34, 37, 40, 44, 46, 47, 48, 50 pk
18	Luftfilter, Doppelluftfilter	Air cleaner, twin air cleaner	Filtre à air, filtre à air double	Filtro aria, filtro aria doppio	Filtro de aire, filtro de aire doble	luchtfilter, dubbel luchtfilter
19	Anschlußteile für Luftfilter	Connecting parts for air cleaner	Pièces de raccord pour filtre à air	Parti di collega- mento p. filtro aria	Piezas de conexión para filtro de aire	aansluitdelen luchtfilter

19-10	Lufftfilter mit Anschlußteilen für Einspritzmotor	Air cleaner with connecting parts for fuel injection engine	Filtre à air avec pièces de raccord pour moteur à injection	Filtro aria con parti di collegamento per motore a iniezione	Filtro de aire con piezas de conexión para motor de inyección	luchtfilter met aansluitdelen voor inspuitmotor
20	Saugrohr und Saugstutzen	Intake manifold and intake pipe	Collecteur d'admission et coude d'admission	Condotto di aspirazione e raccordo di aspirazione	Tubo de aspiración y tubuladura de aspiración	zuigbuis en inlaatspruitstuk
21-10	Abgasrückführung	Exhaust recirculation	Recyclage des gaz d'échappement	Ritorno gas di scarico	Retorno de gases de escape	uitlaatgasherverbranding
21-20	Schubanhebung und Abgasrückführung für Einspritzmotor	Decelerator and exhaust recirculation for fuel injection engine	Air additionnel marche en poussée et recyclage des gaz d'échappement pour moteur à injection	Combustione in decelerazione e ritorno gas di scarico per motore a iniezione	Combustión ulterior durante el empuje y retorno gases para motor de inyección	extra lucht bij afremmen op motor en herverbranding voor inspuitmotor
21-30	Ansauganlage für Einspritzmotor, Einzelteile „Höhenkorrektor“	Intake system — Fuel injection engine, Altitude corrector parts	Tubulure d'admission pour moteur à injection, pièces de correcteur altimétrique	Condotto di aspirazione per motore a iniezione, particolari „correttore altimetrico“	Sistema de aspiración para motor de inyección, piezas suelta „corrector de altura“	inlaatsysteem voor inspuitmotor, losse delen „hoogtecorrectie“
21-40	Kraftstoffleitung mit Ventil für Einspritzmotor	Fuel line with valve for fuel injection engine	Canalisation d'alimentation avec soupape pour moteur à injection	Tubazione carburante con valvola per motore a iniezione	Tubería de gasolina con válvula para motor de inyección	benzineleiding met verstuivers voor inspuitmotor
21-50	Elektrische Kraftstoffpumpe und Steuergerät für Einspritzmotor	Electric fuel pump and electronic control unit for injection engine	Pompe à essence (électrique) et appareil de commande pour moteur à injection	Pompa elettrica carburante e dispositivo elettronico di comando per motore a iniezione	Bomba eléctrica de gasolina y aparato de mando para motor de inyección	elektrische benzinepomp en regelapparaat inspuitmotor
22	Kupplung für Schaltgetriebe und Automatic	Clutch for manual transmission and Automatic	Embrayage pour BV mécanique et Automatic	Frizione per cambio meccanico e Automatic	Embrague p. cambio manual y Automatic	drukgroep voor schakelbak en automatic
23	Ausrücklager, Ausrückwelle, Kupplungshebel für Schaltgetriebe und Automatic	Release bearing, Operating shaft, Clutch operating lever for manual transmission and Automatic	Butée de débrayage, axe de fourchette de débrayage, levier de commande d'embrayage pour BV mécanique et Automatic	Collare di spinta, albero disinnesto, leva comando frizione per cambio meccanico e Automatic	Collar de desembrague eje de desembrague, palanca de embrague p. cambio manual y Automatic	druklager, ontkoppingsas, koppelingshefboom voor schakelbak en automatic
24	Automatische Kupplung mit Servomotor für Saxomat F ---117 999 000	Automatic clutch with clutch servo for Saxomat F ---117 999 000	Embrayage automatique avec servomoteur pour Saxomat F ---117 999 000	Frizione automatica con servomotore per Saxomat F ---117 999 000	Embrague automático con servomotor para Saxomat F ---117 999 000	automatische koppeling met servomotor voor Saxomat F ---117 999 000
25	Servomotor, Öl- und Unterdruckbehälter für Automatic F 118 000 001 ---	Clutch servo, Oil tank and vacuum tank for Automatic F 118 000 001 ---	Servomoteur, Réservoir à huile et réservoir de dépression pour Automatic F 118 000 001 ---	Servomotore, serbatoio olio e depressione per Automatic F 118 000 001 ---	Servomotor, Depósito de aceite y depósito de vacío para Automatic F 118 000 001 ---	servomotor, ATF-en onderdruktankje voor automatic F 118 000 001 ---
	Kraftstoffbehälter Auspuff Heizung	Fuel Tank Exhaust System Heating System	Réservoir à essence Pot d'échappement Chauffage	Serbatoio del carburante Tubazioni di scarico Riscaldamento	Depósito de gasolina Sistema de escape Calefacción	Benzinetank, uitlaat, verwarming
25-10	Kraftstoffbehälter, Kraftstoff-einfüllung	Fuel tank, Fuel filler	Réservoir à essence, goulot de réservoir à essence	Serbatoio del carburante, bocchettone riempimento carburante	Depósito de gasolina, Boca de relleno de gasolina	benzintank, benzinevulpijp
25-20	Aktivkohlebehälter	Activated carbon container	Réservoir à charbon actif	Scatola carbone attivo	Depósito de carbón activo	koofilter
26	Auspufftopf, Austrittsrohr für Vergasermotor	Muffler, Tail pipe for carburetor engine	Pot d'échappement, embout pour moteur à carburateur	Marmitta, tubo di scarico per motore a carburatore	Silenciador, Tubo terminal para motores de carburador	uitlaatpot, uitlaateindpijp voor carburatiemotor
26-10	Auspufftopf, Austrittsrohr und Katalysator für Einspritzmotor	Muffler, tail pipe and catalyst for fuel injection engine	Pot d'échappement, embout et catalyseur pour moteur à injection	Marmitta, tubo di scarico e catalizzatore per motore a iniezione	Silenciador, Tubo terminal y catalizador para motor de inyección	uitlaatpot, uitlaateindpijp en katalysator voor inspuitmotor

27	Heizung (Vergasermotor)	Heater System (carburetor engine)	Chauffage (moteur à carburateur)	Riscaldamento (motore a carburatore)	Calefacción (motor de carburador)	verwarming (carburatie- motor)
27-10	Heizung für Einspritzmotor	Heater for fuel injection engine	Chauffage pour moteur à injection	Riscaldamento per motore a iniezione	Calefacción para motor de inyección	verwarming inspuitmotor
28	Warmluftaustritt hinten	Warm air outlet, rear	Sortie d'air chaud arrière	Bocchetta aria calda posteriore	Salida de aire caliente, trasera	warmeluchtuitlaat achterin
29-10 29-20	Standheizung, Bauart Eberspächer F ---111 3200 000	Eberspächer stationary heater F ---111 3200 000	Chauffage «Eberspächer» F ---111 3200 000	Riscaldamento autonomo Eberspächer F ---111 3200 000	Calefacción estacionaria, tipo «Eberspächer» F ---111 3200 000	Eberspächer F ---111 3200 000
29-30 29-40	Standheizung, Bauart Eberspächer F 112 2000 001 ---	Eberspächer stationary heater F 112 2000 001 ---	Chauffage «Eberspächer» F 112 2000 001 ---	Riscaldamento autonomo Eberspächer F 112 2000 001 ---	Calefacción estacionaria, tipo «Eberspächer» F 112 2000 001 ---	Eberspächer F 112 2000 001 ---

Getriebe	Transmission	Boîte	Cambio	Cambio	Versnellingsbak
----------	--------------	-------	--------	--------	-----------------

30	Getriebegehäuse (Schaltgetriebe)	Transmission case (manual transmission)	Carter de boîtepont (BV mécanique)	Scatola della trasmissione (cambio meccanico)	Caja de cambio (cambio manual)	versnellingsbak- huis (schakelbak)
31	Getriebegehäuse (Automatic)	Transmission case (Automatic)	Carter de boîtepont (Automatic)	Scatola della trasmissione (Automatic)	Caja de cambio (Automatic)	versnellingsbak- huis (automatic)
32	Befestigungsteile für Getriebe	Securing parts for transmission	Pièces d'assem- blage pour boîtepont	Parti fissaggio trasmissione	Piezas de fijación para cambio	bevestigingsdelen versnellingsbak
33	Räder, Wellen (Schaltgetriebe)	Gears, Shafts (manual transmission)	Arbres et pignons (BV mécanique)	Ingranaggi ed alberi (cambio meccanico)	Piñones y árboles (cambio manual)	tandwielen, assen (schakelbak)
34	Räder, Wellen, Wandler (Automatic)	Gears, Shafts, Torque converter (Automatic)	Arbres, pignons et convertisseur (Automatic)	Ingranaggi ed alberi, convertitore di coppia (Automatic)	Piñones y árboles, convertidor (Automatic)	tandwielen, assen, koppelomvormer (automatic)

Vorderachse Lenkung	Front axle Steering	Train-avant Direction	Avantreno Sterzo	Eje delantero Dirección	Vooras, stuurinrichting
------------------------	------------------------	--------------------------	---------------------	----------------------------	----------------------------

35	Vorderrad- aufhängung, Bremstrommel, Bremsscheibe mit Lagerung	Front suspension, brake drum, brake disc with bearings	Suspension avant, tambour de frein, disque de frein avec palier	Sospensione anteriore, tamburo freno, disco freno con cuscinetti	Suspensión de las ruedas delanteras, tambor de freno, disco de freno con cojinete	voorwiel- ophanging, remtrommel, remschijf met lagering
36	Federung vorn, Stoßdämpfer vorn	Springs front, Shock absorber, front	Suspension avant, Amortisseurs avant	Barre di torsione anteriori, Ammortizzatori ant.	Suspensión delantera, Amortiguadores delant.	vering vooras, voorschok- dempers
37	Lenkgetriebe, Gelenkwelle F ---134 2999 000	Steering gear, Universal joint shaft F ---134 2999 000	Boîtier de direction, arbre de pont F ---134 2999 000	Complessivo sterzo, semiasse F ---134 2999 000	Mecanismo de dirección, eje articulado F ---134 2999 000	stuurhuis, stuurstang met kruiskoppelingen F ---134 2999 000
37-10	Lenkgetriebe, Lenkspurstange, Gelenkwelle F 135 2000 001---	Steering gear, Tie rod, Universal joint shaft F 135 2000 001---	Boîtier de direction, Barre de direction, arbre de pont F 135 2000 001---	Complessivo sterzo, Tirante sterzo, semiasse F 135 2000 001---	Mecanismo de dirección, Barra de acoplamiento, eje articulado F 135 2000 001---	stuurhuis, spoorstangen, stuurstang met kruiskoppelingen F 135 2000 001---
38	Lenkrad, Lenkrohr	Steering wheel, steering column	Volant de direction, colonne de direction	Volante, piantone sterzo	Volante, columna de dirección	stuurwiel, stuurpijp

39	Lenkspurstange, Hilfslenker F ---134 2999 000	Tie rod, steering idler arm F ---134 2999 000	Barre de direction, levier de relais F ---134 2999 000	Tirante sterzo, leva di rinvio F ---134 2999 000	Barra de acoplamiento, Brazo de mando auxiliar F ---134 2999 000	spoorstangen, hulppitmanarm F ---134 2999 000
39	Lenkungs-dämpfer F ---134 2999 000	Steering damper F ---134 2999 000	Amortisseur de direction F ---134 2999 000	Ammortizzatore direzione F ---134 2999 000	Amortiguador de dirección F ---134 2999 000	stuurdemper F ---134 2999 000

	Hinterachse	Rear Axle	Train-arrière	Ponte posteriore	Eje trasero	Achteras
40	Doppelgelenk-achse	Double joint axle	Train AR à double articulation	Semiassie a doppia articolazione	Eje de articulación doble	tussenassen
41	Hinterfeder, Hinterachse	Rear suspension, Rear axle	Ressort arrière, Train arrière	Molla post., Retrotreno	Muelle trasero, eje trasero	torsiestaaft, achteras
41	Stoßdämpfer hinten	Shock absorber, rear	Amortisseurs AR	Ammortizzatori posteriori	Amortiguadores traseros	achterschokdempers
42	Ausgleichgetriebe	Differential	Différentiel	Differenziale	Diferencial	differentieel
43	Sperr-differential	Limited slip differential	Différentiel avec dispositif de blocage	Differenziale autobloccante	Diferencial de bloqueo	sperdifferentieel
	Räder Bremsen	Road wheels Brakes	Roues Freins	Ruote Freni	Ruedas Frenos	Wielen, remmen
44	Scheibenrad	Road wheels	Roues	Ruote	Llanta	velg
45	Bremsträger — Bremsbacken mit Belägen vorn	Back plate, brake shoes with linings, front	Plateau de frein, segments et garnitures (AV)	Dischi portafreno — ganasce ant. con guarnizioni	Portafreno — zapatas de freno con forros, delante	remankerplaat - remschoenen met -voeringen voorwielen
46	Bremsträger — Bremsbacken mit Belägen hinten	Back plate, brake shoes with linings, rear	Plateau de frein, segments et garnitures (AR)	Dischi portafreno — ganasce post. con guarnizioni	Portafreno — zapatas de freno con forros, detrás	remankerplaat - remschoenen met -voeringen achterwielen
47	Hauptbremszylinder	Brake master cylinder	Maitre-cylindre	Pompa comando freni	Cilindro principal de freno	hoofdremcilinder
48	Radbremzylinder	Wheel brake cylinder	Cylindre récepteur	Cilindretto freno	Cilindro de freno de rueda	wielremcilinder
49	Ausgleichbehälter und Leitungen	Reservoir with lines	Réservoir compensateur avec conduites	Serbatoio di compensazione con tubazioni	Depósito de compensación con tuberías	remvloeistof-reservoir en leidingen
50	Leitungen — Bremskreis vorn	Front brake circuit lines	Conduites pour circuit avant	Tubazioni per circuito freni ant.	Tuberías para circuito de freno del.	leidingen voorste remcircuit
51	Leitungen — Bremskreis hinten	Rear brake circuit lines	Conduites pour circuit arrière	Tubazioni per circuito freni post.	Tuberías para circuito de freno tras.	leidingen, achterste remcircuit
52	Scheibenbremse	Disc brakes	Freins à disque	Freni a disco	Freno de disco	schijfremmen
	Rahmen Hand- und Fußhebelwerk	Frame Hand lever system Pedal cluster	Châssis Commandes à main et pédalier	Telaio Comandi a mano ed a pedale	Bastidor Palancas y pedales de mando	Chassis, hendels en pedalen
53	Rahmen, Rahmenkopf, Bodenblech	Frame, Frame head, Floor plate	Châssis, Tête de châssis, Plancher de châssis	Telaio, Testa telaio, lamiera di fondo	Bastidor, Cabeza del bastidor, Chapa del piso	chassis, chassiskop, bodemplaat
54	Stoßfänger vorn	Bumpers front	Pare-chocs avant	Paraurti anteriore	Parachoques delantero	voorbumper

54-10	Pralldämpfer mit Stoßfänger vorn	Buffer with bumper, front	Elément antichocs avec pare-chocs AV	Ammortizz. urto con paraurti anteriore	Amortiguador choques con parachoques delantero	Demper voorbumper en voorbumper
55	Stoßfänger hinten	Bumpers rear	Pare-chocs arrière	Paraurti posteriore	Parachoques trasero	achterbumper
55-10	Pralldämpfer mit Stoßfänger hinten	Buffer with bumper, rear	Elément antichocs avec pare-chocs AR	Ammortizz. urto con paraurti posteriore	Amortiguador choques con parachoques trasero	Demper achterbumper en achterbumper
56	Schaltbetätigung für Schaltgetriebe	Shift mechanism for manual transmission	Commande des vitesses pour boîte mécanique	Meccanismo cambio comandato a mano	Accionamiento del cambio manual	schakelmechanisme, schakelbak
57	Handbremshebel	Hand brake lever	Levier de frein à main	Leva del freno a mano	Palanca de freno de mano	handremhendel
58	Heizklappenzug	Heating control cable	Câble de chauffage	Cavo comando valvola riscaldamento	Cable de calefacción	regelkabel verwarming
59	Schaltbetätigung für Automatic	Shift mechanism for Automatic	Commande des vitesses pour Automatic	Meccanismo per Automatic	Accionamiento para Automatic	schakelmechanisme automatic
60	Brems- und Kupplungsfußhebelwerk	Brake and clutch pedal cluster	Commande des freins à pied et de l'embrayage	Pedaliera per pedali freno e frizione	Pedales de freno y de embrague	rem- en koppelingspedaal
61	Gasfußhebelwerk, Vergaserzug, Kupplungsseil	Accelerator pedal cluster, Accelerator cable, Clutch cable	Commande d'accélérateur, Câble d'accélérateur, Câble de débrayage	Pedaliera acceleratore, cavo comando acceleratore, fune frizione	Pedales de mando, cable de acelerador, cable de embrague	gaspedaal, gaskabel, koppelingskabel
62	Bremsfußhebel – Automatic	Brake pedal – Automatic	Pédale de frein – Automatic	Pedale del freno – Automatic	Pedal de freno – Automatic	rempedaal – automatic

	Aufbau	Body	Carrosserie	Carrozzeria	Carrocería	Carrosserie
63	Aufbau, Aufbau-Vorderteil	Body, Body front section	Carrosserie, Avant de carrosserie	Carrozzeria, carrozzeria parte anteriore	Carrocería, Carrocería - parte delantera	carrosserie, voorstuk carr.
64	Unterholm, Querträger	Side and cross members	Longerons, traverse	Longarine inferiori, supporto trasversale	Larguero inferior, travesaño	grondbalk, dwarsversterking
65	Vorderteil	Front section	Avant de carrosserie	Parte anteriore	Parte delantera	neus
66	Seitenteil vorn und hinten	Side panel front and rear	Panneaux latéraux avant et arrière	Fiancate anteriore e posteriore	Parte lateral delant. y tras.	voorste en achterste zijpaneel
67	Tankklappenzug, Tankklappe	Release cable – Tank filler flap	Tirette de portillon de réservoir	Fune comando sportello bocchettone, sportello bocchettone	Cable de accionamiento tapa del depósito de gasolina, Tapa del depósito de gasolina	trekkabel, benzinevulklep, benzinevulklep
68	Hinterteil	Rear section	Arrière de carrosserie	Parte posteriore	Parte trasera	achterstuk
69	Dach	Roof	Pavillon	Tetto	Techo	dak
70	Warmluftaustritt vorn, Be- und Entlüftung, Frischluftregulierung F ---112 3200 000	Warm air outlet, front, Ventilation, fresh air regulator F ---112 3200 000	Sortie d'air chaud avant, Ventilation, Régulateur d'aération F ---112 3200 000	Bocchetta aria calda anteriore, ventilazione, regolazione aria fresca F ---112 3200 000	Salida de aire caliente, delantera, Ventilación, regulador de aire F ---112 3200 000	warme luchtuitlaat voorin, ventilatie, -regeling F ---112 3200 000
71	Frischluftgebläse F ---112 3200 000	Fresh air fan F ---112 3200 000	Soufflante d'air frais F ---112 3200 000	Ventilatore aria fresca F ---112 3200 000	Turbina de aire de ventilación F ---112 3200 000	ventilator F ---112 3200 000
72	Warmluftaustritt vorn F 133 2000 001 --- 133 3200 000	Warm air outlet, front F 133 2000 001 --- 133 3200 000	Sortie d'air chaud avant F 133 2000 001 --- 133 3200 000	Bocchetta aria calda anteriore F 133 2000 001 --- 133 3200 000	Salida de aire caliente, delantera F 133 2000 001 --- 133 3200 000	uitstroomopeningen warme lucht voorin F 133 2000 001 --- 133 3200 000

72-10	Frischluffgebläse, Be- und Entlüftung, Frischluftregulierung F 133 2000 001 ---	Fresh air fan, Ventilation, Fresh air regulator F 133 2000 001 ---	Soufflante d'air frais, Ventilation, Régulateur d'aération F 133 2000 001 ---	Ventilatore aria fresca, ventilazione, regolazione aria fresca F 133 2000 001 ---	Turbina de aire de ventilación, ventilación, regulador de aire F 133 2000 001 ---	ventilator, ventilatie, -regeling F 133 2000 001 ---
73	Kotflügel, Einsteigverkleidung, Schmutzfänger hinten	Fender, Sill panel, Mud flaps, rear	Ailes, marchepieds, pare-boue AR	Parafanghi, rivest. pedane, paraspruzzi post.	Guardabarros, estribos, faldones tras.	spatschermen, treeplankrubbers, achterspatlappen
74	Deckel und Deckelschloßbetätigung vorn	Hood and hood lock control, front	Capot et commande de serrure de capot AV	Cofano e comando apertura cofano anteriore	Capó y accionamiento de la cerradura del capó del.	voordeksel met trekkabel
75	Deckel hinten	Rear hood	Capot arrière	Cofano posteriore	Capó trasero	achterdeksel
76	Türen, Türscharniere, Türdichtungen	Doors, Door hinges, Door weatherstrip	Portes, Charnières de portes, Joints de portes	Portiere, cerniere per porta, guarnizioni porta	Puertas, bisagras de puerta, juntas de puerta	portieren, portierscharnieren, en -rubbers
77	Türschloß mit Innenbetätigung	Door lock with operating lever	Serrure de porte avec commande à distance	Serratura porta con comando interno	Cerradura de puerta con accionamiento int.	portierslot met binnenbediening
78	Türgriff, Türfeststeller, Türpuffer	Door handle, Door check rod, Rubber buffer	Poignée de porte, Arret de porte, butée de porte	Maniglia per porta, asta bloccaporta, tampone riscontro porta	Picaporte de puerta, retentor de puerta, tope de puerta	portiergreep, -vanger, -buffer
79	Drehfenster-, Türfensterrahmen, Führungsschienen	Vent wing, Door window frame, channels	Cadre de déflecteur, cadre de glace de porte, Coulisseaux de porte	Telaietto per deflettore, telaio per cristallo porta, canalini di guida	Marco de ventanilla deflectora, marco de ventanilla para puerta, correderas-guía	frame ventilatieruitje, frame portierruit, geleiderails
80	Fensterheber, Türfensterhebeschienen, Fensterkurbel	Door window winder, Door window lift channel, Door window winder handle	Lève-glace, chaussure de glace de porte, manivelle de lève-glace	Alzacristallo, canalino alzacristallo, manovella alzacristallo	Levantavidrios, canal levantavidrios de la puerta, manivela levantavidrios	ruitmechanisme, ruitdrukstuk, raamslinger
81	Drehfenster	Vent wing	Déflecteur	Deflettore	Ventanilla deflectora	ventilatieruitje
82	Fensterscheiben und Dichtungen	Window glasses and weatherstrips	Glaces et joints	Cristalli e guarnizioni	Cristales y juntas	ruiten en -rubbers
82	Ausstellfenster	Hinged windows	Glaces pivotantes	Finestrini orientabili	Ventanilla lat., regulable	uitzetruit
83	Schwenkfenster	Drop windows	Glaces descendantes	Parti dei finestrini a scomparsa	Ventanilla abatible	tuimelruiten
84	Zierleisten, Schriftzüge	Moldings, Signs	Moulures, Monogrammes	Mondanature, scritte	Molduras de adorno, rótulos	sierlijsten, opschriften
85	Schalttafelabdeckung, Schalttafelkasten mit Deckel und Verschuß	Instrument panel cover, Glove compartment with lid and catch	Cache de tableau de bord, vide-poches avec battant et serrure	Rivestimento crusotto, cassetto portaoggetti con sportello e fermo a scatto	Pantalla de tablero de instrumentos, guantera con tapa y cerradura	dashboardbekleidung, dashboardkastje met deksel en slot
86	Zierritter, Ascher	Grille, Ashtray	Grille ornementale, cendrier	Griglia, portacenere	Rejilla de adorno, cenicero	sierrooster, asbakje
87	Rückblicksiegel, Sonnenblende, Haltegriff und Halteschleife	Rear view mirror, Sun visor, Grab handle and assist strap	Rétroviseur, pare-soleil, poignée et sangle passe-bras	Specchio retrovisivo, aletta parasole, maniglia e manopola di appiglio	Espejo retrovisor, parasol, asidero y asidero de lazo	binnenspiegel, zonnekleppen, handgreep en handlussen
88-10 88-20	Sicherheitsgurt, Verbandskastenhalterung	Safety belt, Mounting parts for first aid kit	Ceintures de sécurité, Fixation de boîte à pansements	Cintura di sicurezza, parti fissaggio cassetta pronto soccorso	Cinturón de seguridad, fijación para botiquín de urgencia	veiligheidsriemen, verbandtrommelhouder
89	Verkleidungen: Vorderwand, Unterholm, Radhaus, Kofferboden, Handbremshebel, Rahmentunnel	Interior trim: Front panel, Side member, Wheel housing, Luggage compartment, Hand brake lever, Frame tunnel	Garnitures: Tablier, Longeron, Passage de roue, Fond de coffre, Levier de frein à main, Tunnel	Rivestimenti: parete anteriore, longarina inf., passaruota, vano bagagli, leva freno a mano, copritunnel	Revestimientos: salpicadero, larguero inf., caja de rueda, portaequipajes, palanca del freno de mano, tunel del bastidor	bekleding: voorwand, grondbalk, wielkast, kofferbakbodem, handremhendel, chassistunnel
90	Pappe für Gepäckwanne	Fiber board — Front luggage compartment	Carton de coffre à bagages	Cartone per bagagliaio anteriore	Cartón para bandeja portaequipajes	bekleding voorste kofferbak

91	Fußstütze, Bodenbelag, Dämpfungen	Foot support, Floor mat, Sound absorbers	Repose-pieds, Tapis de sol, Revêtements d'insonorisation	Appoggiapiedi, tappeto, rivesti- menti antirumbo	Descansa-pies, esterilla, revesti- miento amori- guador	voetensteun, bodembekleding, geluiddempend materiaal
92	Türverkleidung, Seitenverklei- dung, Armlehne	Door and side trim panels, Arm rest	Garniture de porte, Garniture de custode, Accou- doir	Tappezzeria per porta, tappezzeria laterale, bracciuolo	Revestimiento de la puerta, revesti- miento lateral, des- cansabrazos	portierbekleding, bekleding zijpa- neel, arMLEuning
93	Türsäulen- und Dach- verkleidung	Door pillar lining and roof lining	Montant de porte — Garniture de pavillon	Rivestimento tetto montante centrale	Revestimiento montantes de puerta — Revesti- miento del techo	portierstijl- en hemelbekleding
94	Verdeckbezug Cabriolet	Top Cover Convertible	Capotage des Cabriolets	Copertura Cabriolet	Capota Cabriolet	cabrioletkap
95	Verdeckspitze, Verdeckschloß	Top frame header, Top lock	Frise d'éventail de capotage, Méca- nisme de fermeture	Testata capote, serratura su centina chiusura	Cabezal de capota, cierre de capota	sluittoog, kaps- luiting
96	Verdeckgestell F ---151 3200 000	Frame-Top F ---151 3200 000	Eventail de capotage F ---151 3200 000	Armatura per capote F ---151 3200 000	Armazón para capota F ---151 3200 000	frame cabrioletkap F ---151 3200 000
95-10	Verdeckgestell F 152 2000 001 ---	Frame-Top F 152 2000 001 ---	Eventail de capotage F 152 2000 001 ---	Armatura per capote F 152 2000 001 ---	Armazón para capota F 152 2000 001 ---	frame cabrioletkap F 152 2000 001 ---
97	Stahlkurbeldach	Steel sliding roof	Toit coulissant métallique	Tettuccio d'acciaio apribile a mano- vella	Techo corredizo de acero, a mani- vella	schuifdak
98	Stahlkurbeldach- Einbauteile	Steel sliding roof parts	Toit coulissant — Pièces de montage	Tettuccio d'acciaio apribile a mano- vella — parti interne	Techo corredizo de acero, a mani- vella — Piezas de montaje	inbouwdelen schuifdak
99	Sitz vorn F ---135 2600 000	Seat, front F ---135 2600 000	Siège AV F ---135 2600 000	Sedile anteriore F ---135 2600 000	Asiento delantero F ---135 2600 000	zitting stoel F ---135 2600 000
99-10	Sitz vorn F 156 2000 001 ---	Seat, front F 156 2000 001 ---	Siège AV F 156 2000 001 ---	Sedile anteriore F 156 2000 001 ---	Asiento delantero F 156 2000 001 ---	stoelen F 156 2000 001 ---
100	Rückenlehne vorn F ---135 2600 000	Backrest, front F ---135 2600 000	Dossier AV F ---135 2600 000	Schienale anteriore F ---135 2600 000	Respaldo delantero F ---135 2600 000	leuning stoel F ---135 2600 000
100-10	Rückenlehne vorn F 156 2000 001 ---	Backrest, front F 156 2000 001 ---	Dossier AV F 156 2000 001 ---	Schienale anteriore F 156 2000 001 ---	Respaldo delantero F 156 2000 001 ---	leuning stoel F 156 2000 001 ---
101	Sitz- und Rücken- lehne hinten	Seat and Backrest rear	Banquette AR et dossier	Sedile e schienale posteriore	Respaldo asiento y respaldo trasero	achterbank met leuning
102	Befestigungsteile für Aufbau auf Fahrgestell	Body to chassis securing parts	Pièces d'assem- blage de la carrosserie sur le châssis	Pezzi di fissaggio della carrozzeria al telaio	Piezas para fijación de la carrocería al chasis	bevestigingsdelen carroserie op chassis
	Elektrische Ausrüstung	Electrical equipment	Equipement électrique	Equipaggiamento elettrico	Instalación elétrica	Elektrische uitrusting
103	Lichtmaschinen und Einzelteile, Spannungsregler	Generators and parts, Voltage regulator	Dynamos et pièces constitutives, Régu- lateur de tension	Dinamo e parti- colari, regolatore tensione	Dínamos y piezas sueltas, Regulador de tension	dynamo en delen dynamo, spanningsregelaar
103-10 103-20	Drehstrom- generator	Alternator	Alternateur	Alternatore	Alternador	wisselstroom- dynamo
104	Zündverteiler, Zündverteiler- Einzelteile	Distributors, Distributor parts	Distributeur, Pièces du distributeur	Distributore d'accensione, particolari distributore	Distribuidor, Piezas del distribuidor	stroomverdeler en delen stroom- verdeler
105	Zündspule, Zündkerze, Zündkerzen- stecker, Zündleitung, Triggerimpuls- geber, Totpunkt- markengeber	Coil, Spark plug, Plug connector, Ignition cable, Trigger impulse coil, TDC marker relay	Bobina d'allumage, Bougie, Fiche de bougie, Câbles d'allumage, Emet- teur d'impulsions de déclenchement, Jauge de repère du point mort	Bobina d'accen- sione, candela, attacco candela, cavo d'accensione, eccitatore, rivelatore P.M.	Bobina, Bujía, Enchufe de bujía, Cable de encendido, Impulsor trigger, Indicador de punto muerto	bobine, bougies, bougiestekers, ontstekingskabels, ontstekingsstij- stipvoeler, b.d.p.-voeler
106	Zünd-Anlaß- schalter, Lenkschloß	Ignition starter switch, Steering lock	Interrupteur contact-démarrreur antivol direction	Interruttore accen- sione-avviamento, serratura blocca- sterzo	Interruptor de encendido y arranque, Cerra- dura de dirección	contact- start- schakelaar, stuurslot

107	Anlasser, Anlasser-Einzelteile, Batteriebefestigung, Trennrelais	Starting motor, Starting motor parts, Battery mounting, Circuit breakers	Démarrreur, Pièces du démarreur, Fixation de batterie, relais de coupure	Motorino di avviamento, particolari motorino di avviamento, Fissaggio batteria, relais disgiuntore	Motor de arranque, Piezas del motor de arranque, Fijación de la batería, relé separador	startmotor en delen daarvan, accubestijging, scheidingsrelais
108	Geber, Zeituhr, Zweikreis- und Handbrems-Kontrolleuchte, Richtstrahlleuchte, Öldruckschalter	Fuel gauge, clock, Dual circuit and hand brake warning light, Spot light, Oil pressure switch	Jauge, montre, Témoin du frein à main et du double circuit de freinage, faisceau dirigé, contacteur de pression huile	Galleggiante, orologio, spia contr. doppio circuito e leva freno a mano, luce direzionale, interruttore controllo pressione olio	Impulsor, reloj Luz control freno doble circuito y freno de mano, luz dirigida, interruptor presión aceite	vlotterelement, elektr. klokje, controlelampje 2-krings remstelsysteem en handrem, bundellampje, oliedrukschakelaar
109	Kontrollschalter — Automatic	Control switch — automatic	Contacteur de contrôle — Automatic	Innerruttore di controllo — automatic	Interruptor de control — Automatic	controleschakelaar — automatic
110	Sicherungsdosen, Anschlußklemmen	Fuse boxes, connectors	Boîtes à fusibles, Raccords de câbles	Portavalvole, morsetti con fusibile	Cajas de fusibles, bornes de conexión	zekeringendoos, aansluitklemmen
111	Scheinwerfer F —134 2153 056	Headlamp F —134 2153 056	Phares F —134 2153 056	Fari F —134 2153 056	Faros F —134 2153 056	koplampen F —134 2153 056
111-10	Scheinwerfer F 134 2153 057 —	Headlamp F 134 2153 057 —	Phares F 134 2153 057 —	Fari F 134 2153 057 —	Faros F 134 2153 057 —	koplampen F 134 2153 057 —
111-20	Halogen-Nebelscheinwerfer	Halogen fog lamps	Phares antibrouillard à iode	Proiettore fendinebbia alogeno	Faros antiniebla halógenos	halogeen mistlampen
112	Schalter für Licht, Relais	Light switches, relay	Commutateur d'éclairage, relais	Interruttori per illuminazione, relais	Conmutador p. luz, Relé	lichtschakelaars, relais
113	Kennzeichenleuchte	Licence plate light	Feu de plaque	Luce targa	Luz de matrícula	kentekenlicht
114-10 114-20	Schlußleuchte, Schlußleuchte mit Rückfahrleuchte, Bremslichtschalter, Steckhülsgewehäuse und Schutzkappe, Nebelschlußleuchte	Tail light, Tail light with back-up light, Brake light switch, Terminal sleeve housing and boot, Rear fog light	Feux arrière, Feux arrière avec feu de recul, Contacteur de feux stop, Boîtier à fiches et capuchon, Feu antibrouillard AR	Fanalini posteriori, fanalini posteriori con fari retromarcia, interruttore per luci di arresto, prese e cuffia di protezione, fari antinebbia post.	Luces traseras, luces traseras con fari de marcha atrás, interruptor de luz de pare, caja casquillo enchufe y guardapolvos, luz tras. para niebla	achterlicht, achterlicht met achteruitrijlamp, stoplichtschakelaar, stekkerhuis en stofkap, mistachterlicht
115	Innenleuchte, Rückblickspegel mit Innenleuchte, Tür-Kontaktschalter, Handbremskontrollschalter, Blinkleuchte seitlich	Interior light, rear view mirror with interior light, door contact switch, hand brake control switch, side flashing indicator	Plafonnier, rétroviseur avec plafonnier, contacteur de porte, contacteur du frein à main, clignotants latéraux	Plafoniera, specchio retrovisivo con plafoniera, interruttore aut. porta, interr. leva freno a mano, lampeggiatore laterale	Luz interior, espejo retrovisor con luz interior, interrup. contacto puerta, conmutador control de freno de mano, luz intermitente lateral	binnenlicht, binnenspiegel met binnenlicht, portierschakelaar, handremcontroleschakelaar, zijknipperlichten
116	Signalhorn, Signalhornbügel, Summer	Horn, Horn ring, Buzzer	Avertisseur, Cercle, Vibreur	Avvisatore, settore comando avvisatore, cicalina di richiamo	Bocina, Semiaro de bocina, Zumbador	claxon, claxonbeugel, zoemer
117	Blinkleuchte vorn	Flashing indicator, front	Clignotants avant	Lampeggiatore anteriore	Luz intermitente del.	voorste knipperlicht
117-10	Blinkrelais, Blink-Warnlicht-Relais, Warnlichtschalter; elektrische Teile für Anhänger	Flashing indicator relay, Emergency light relay; electrical parts for trailer	Relais de feux clignotants, Relais pour avertisseur 4 clignotants; Pièces d'équipement électrique pour remorque	Intermittenza, relè per lampeggio — emergenza, interruttore per lampeggio di emergenza; parti elettriche per rimorchio	Impulsor para luces intermitentes, Relé combinado para luces intermitentes y de emergencia, Interruptor de luces de emergencia; Piezas eléctricas para remolque	knipperrelais, knipper-waarschuivingsrelais, schakelaar waarschuivingslicht; elektrische delen voor aanhanger
118	Blinkerschalter, Kombinationschalter	Flashing indicator switch, Combination switch	Commutateur clignotants à rappel automatique, Signalisation	Interruttore lampeggiatori, interruttore combinato	Interruptor de luces intermitentes, Conmutador combinado	knipperschakelaar, combischakelaar

119	Scheibenwischer- rahmen, Scheiben- wischerarm und Scheibenwischer- blatt	Frame — wind- shield wipers, windshield wipers and blade — windshield wiper	Chassis d'essuie-glace, bras d'essuie- glace et raclette d'essuie-glace	Telaio per tergicristallo, racchetta des. con spatola e spatola tergitrice	Chapa de soporte, brazo der. de limpiaparabrisas y rasqueta de limpiaparabrisas	ruitewisserframe, wisserarm en -blad
120	Scheibenwasch- anlage	Windshield washer	Lave-glace	Lavacristallo	Lavaparabrisas	ruitesproeier- installatie
120-10	Scheinwerfer- waschanlage	Headlight washer	Lave-phares	Impianto lavafari	Lavafaros	koplamp- sproeiers
121	Scheibenwischer- motor und Einzel- teile	Wiper motor parts	Pièces du moteur de l'essuie-glace	Motorino tergicristallo e particolari	Piezas del motor limpiaparabrisas	ruitewissermotor en delen wisser- motor
122	Geschwindigkeits- messer, Kraftstoff- vorratsanzeiger, Katalysator- und Geschwindigkeits- überwachung	Speedometer, fuel gauge, catalyst and speed indicator	Tachymètre, indicateur de niveau d'essence, contrôle catalyseur et vitesse	Tachimetro, indicatore livello carburante, controllo catalizzatore e velocità	Velocímetro, indicador de gasolina, control catalizador y límite velocidad	snheidsmeter, benzinemeter, katalysator- en snheidscontrole
123	Elektrische Leitungen	Electric wiring	Câblages	Conduttori elettrici	Cables eléctricos	elektrische kabels
124	Steckhülsen, Flachstecker, Stoßverbinder, Kabelschuhe, Leitungen, Isolierschlauch	Terminal pin, flat terminal, butt connector, connector, cables, insulating tube	Fiches femelles, fiches plates, connecteurs em- bouts, cosses de câbles, câbles, flexible isolant	Prese a innesto, innesti piatti, con- giuntori di testa, capicorda, con- duttori, tubo flessi- bile isolante	Casquillos de enchufe, enchufe plano, conector a tope, terminales de cable, cables, tubo aislante	stekerhulzen, platte stekers, verbind- ingsstekers, kabelschoenen, kabels, olieklus tubo aislante
125	Steckergehäuse, Steckhülsen- gehäuse	Terminal housing, connector housing	Boîtier de douilles à fiches	Scatola innesti, scatola prese	Caja de enchufe, caja casquillo enchufe	stekerhuis, contrastekerhuis
126	Rundstecker und Rundsteckhülsen	Terminal pins and round connector sleeves	Fiches rondes et fiches femelles rondes	Spine cilindriche e prese cilindriche	Espiga de enchufe y casquillos de enchufe	ronde stekers en stekerhulzen
127	Gummitüllen	Grommets	Protecteurs	Boccole di gomma	Boquillas de goma	doorvoer- rubbers
128	Elektrische Teile für beheizbare Rückblickfenster- scheibe	Installation parts for stationary heater	Pièces d'équipe- ment électrique, pour dégivrage de lunette AR	Parti elettriche per cristallo, lunotto riscaldabile	Piezas eléctricas para cristal de ventanilla trasera calentable	elektrische delen verwarmde achterruit

Zubehör
Accessories
Accessoires
Accessori
Accesorios
Toebehoren

130	Wagenheber Werkzeuge	Jack Tools	Cric Outils	Martinetto Attrezzi	Gato Herramientas	krik gereedschap
-----	-------------------------	---------------	----------------	------------------------	----------------------	---------------------

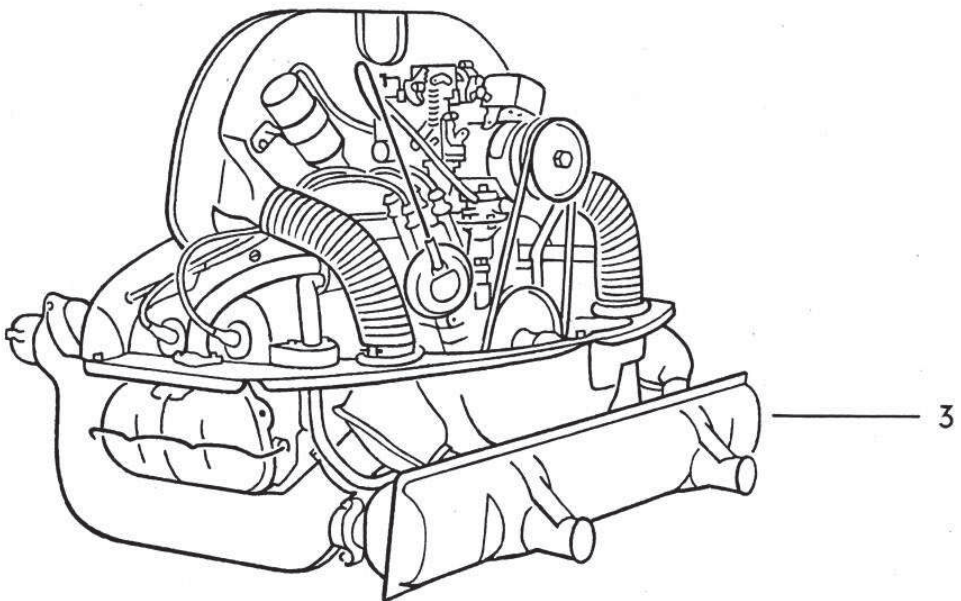
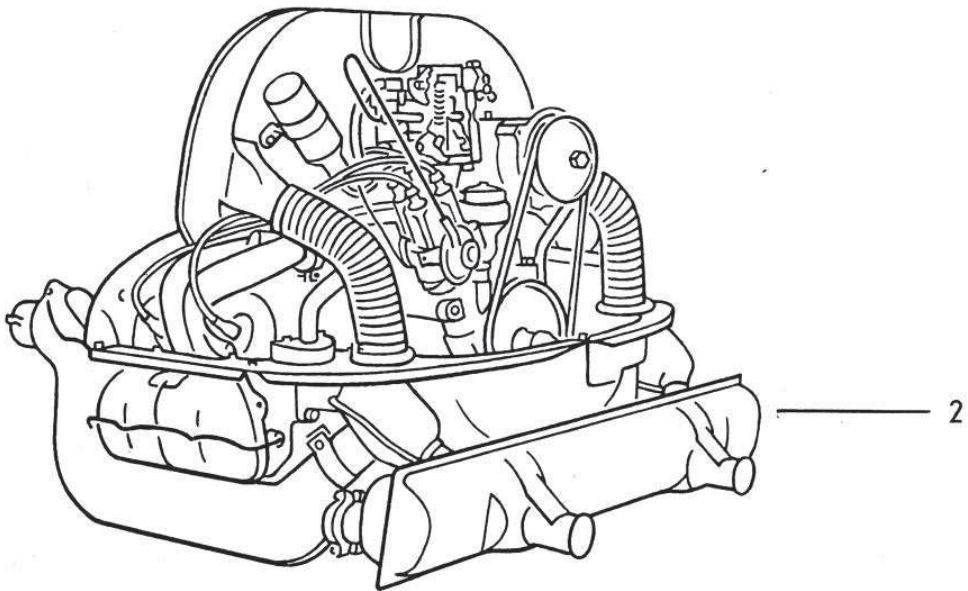
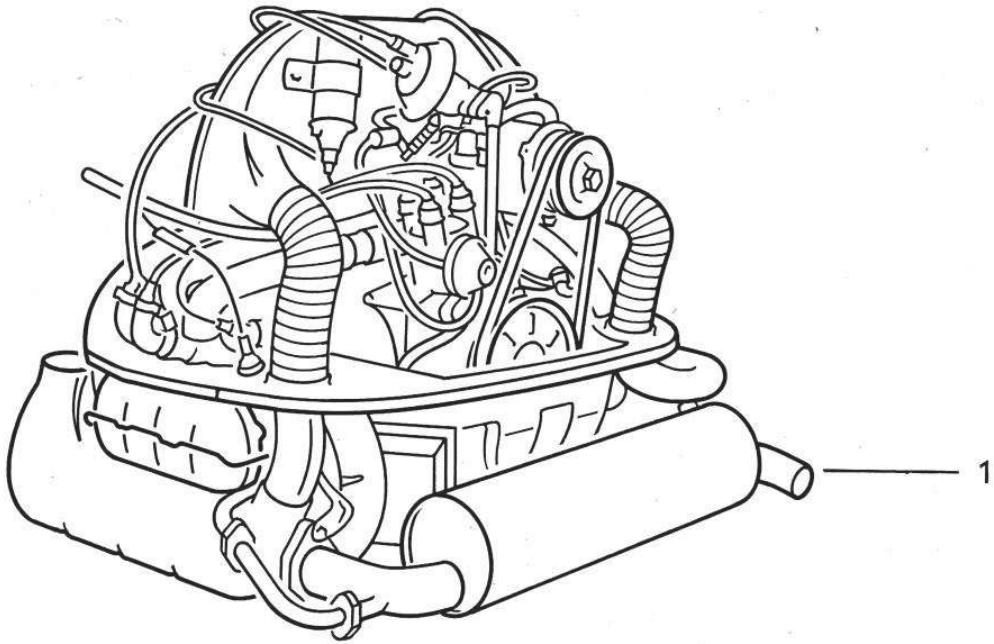

- 1
3 4 6 9 10 14 18 21 22 25 26 30 31 33 34 35
38 40 50

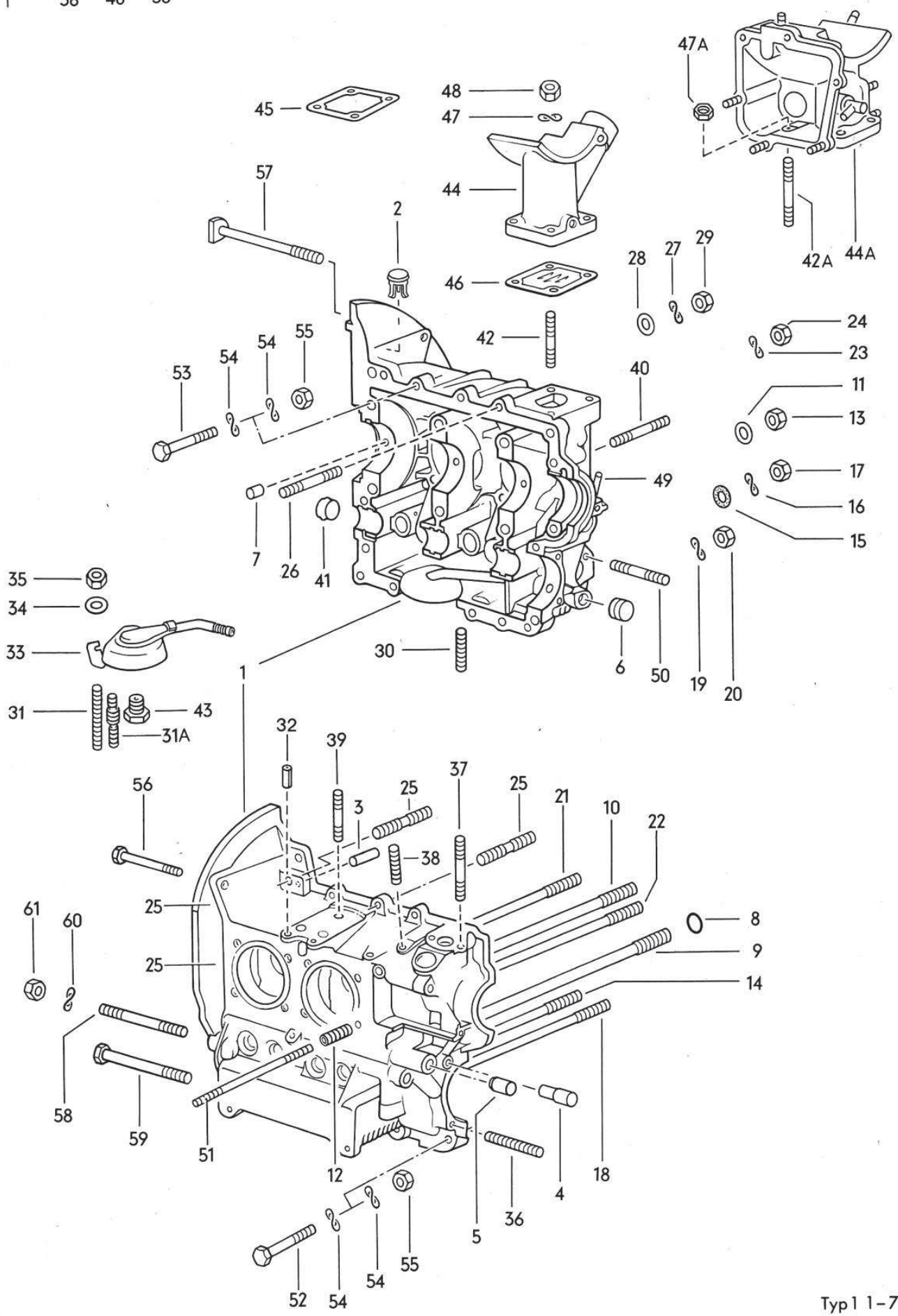

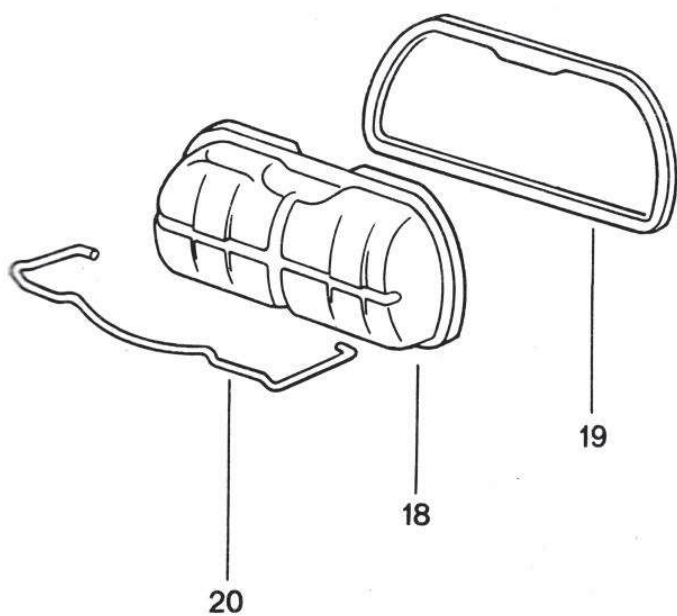
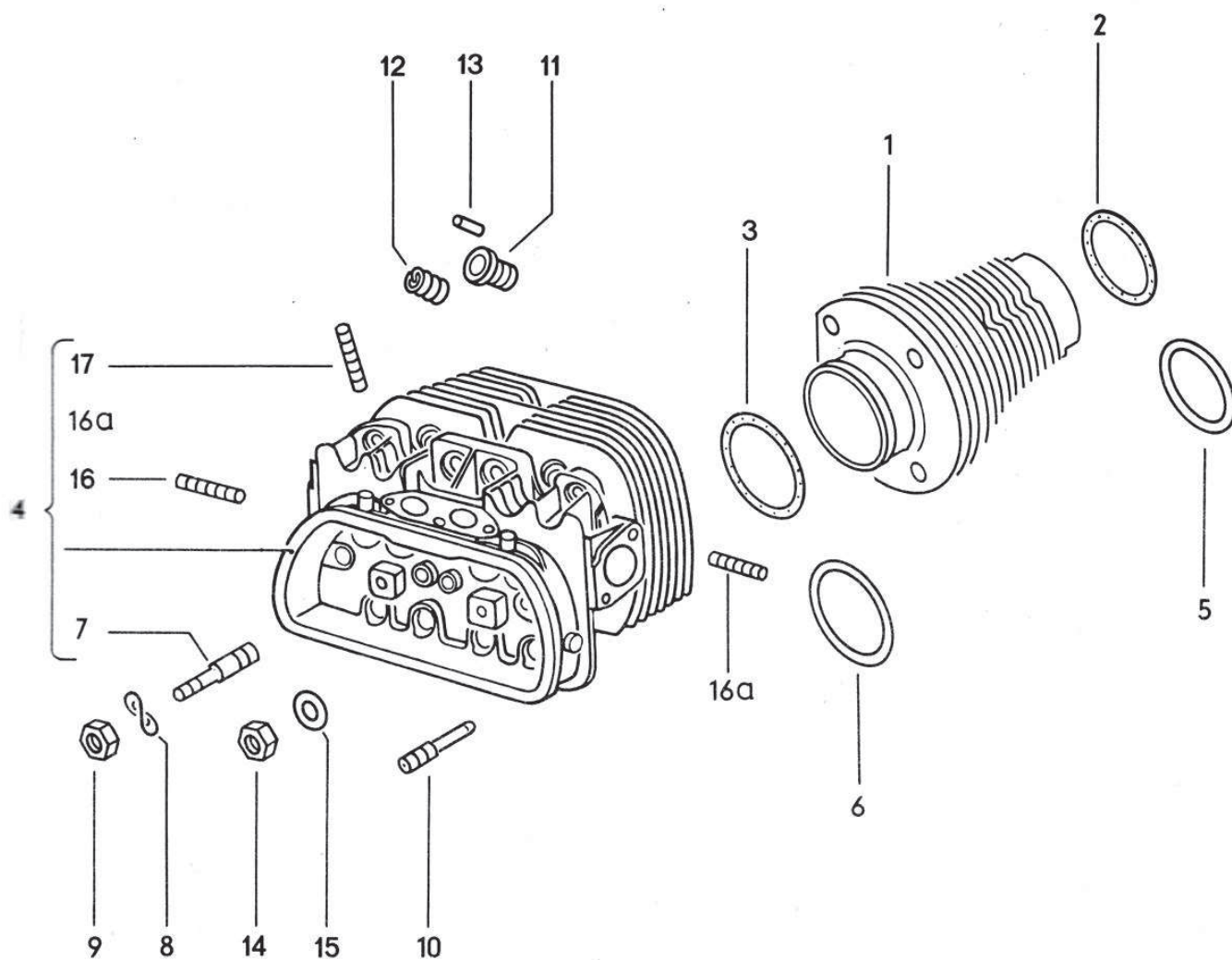

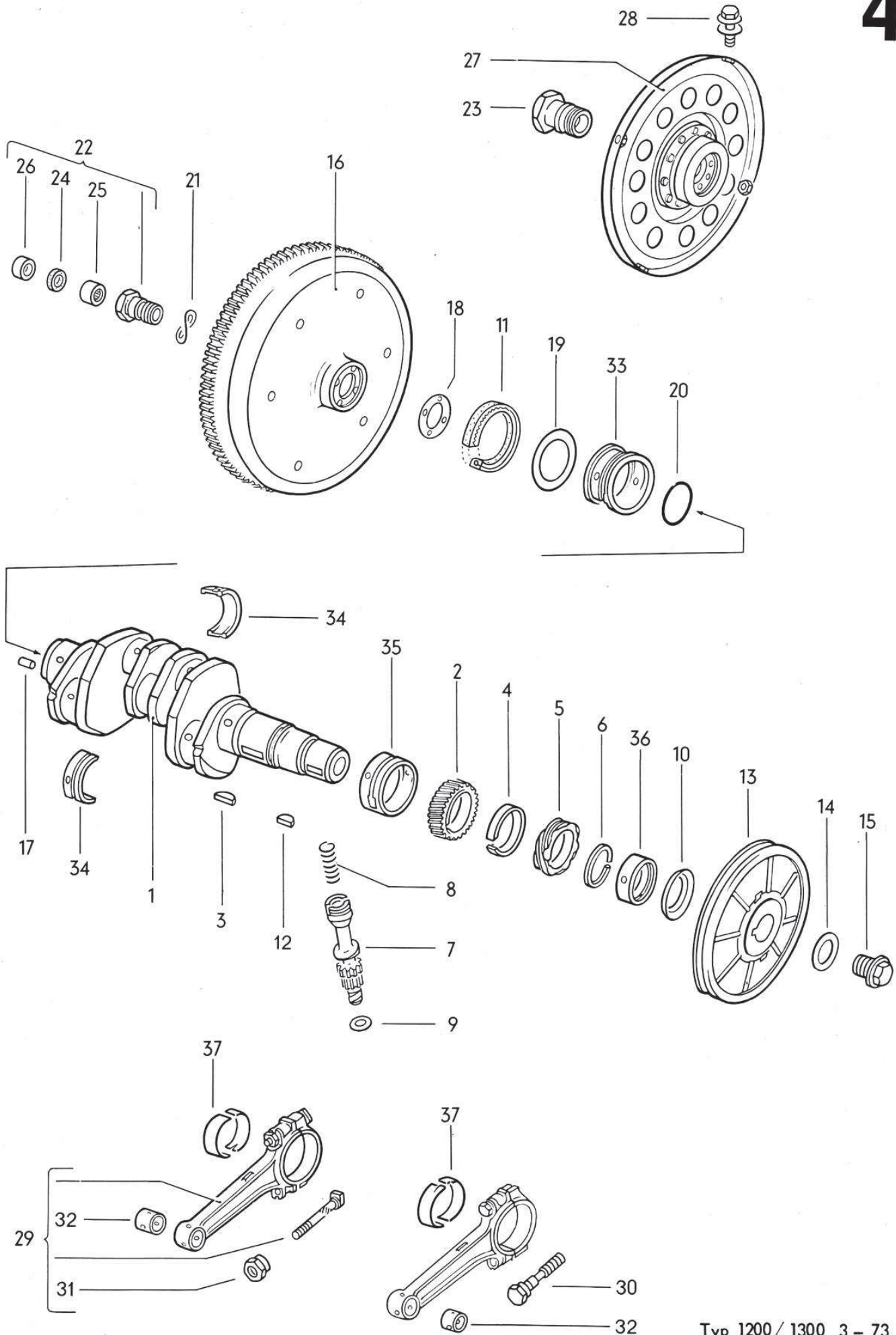

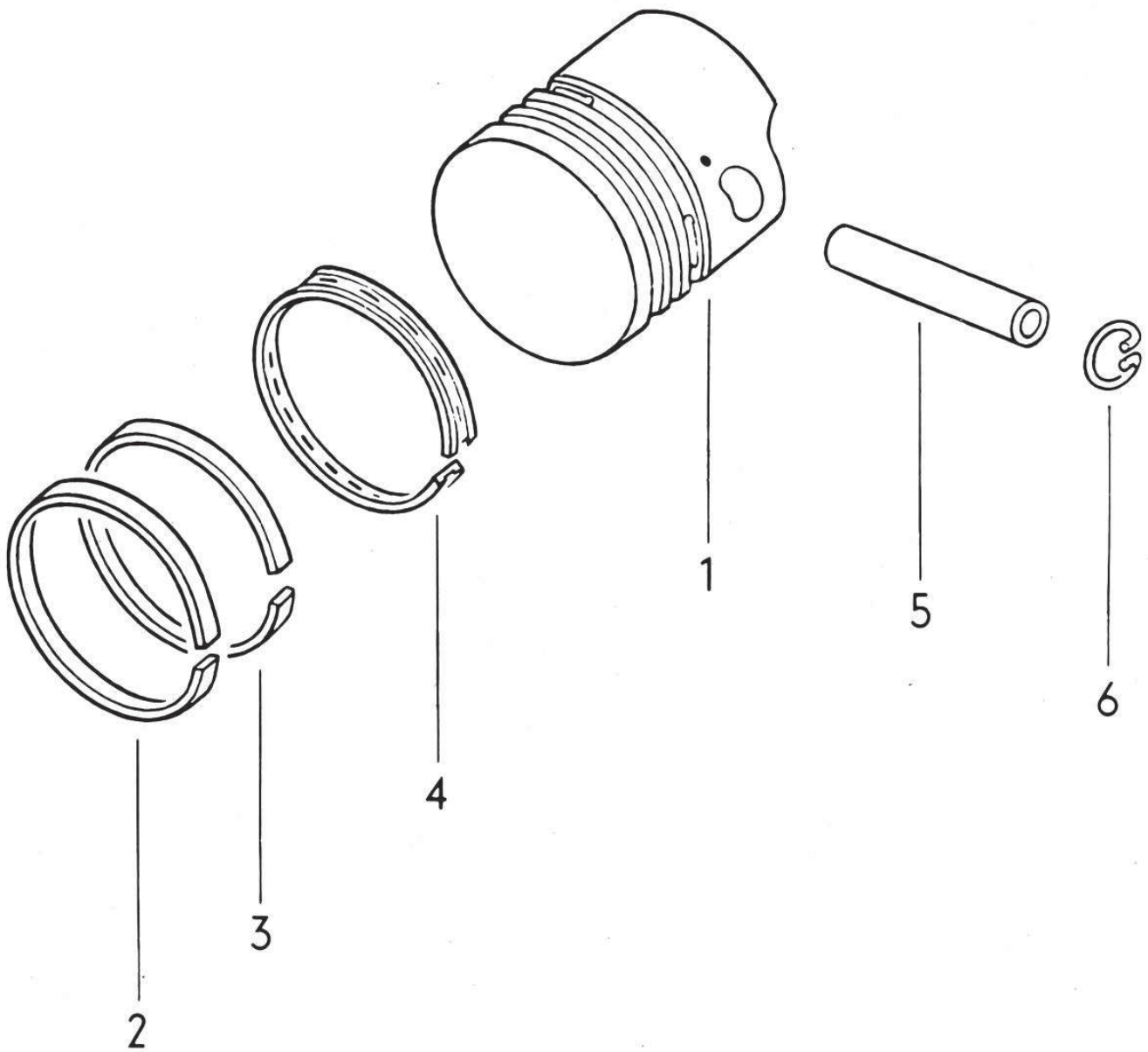

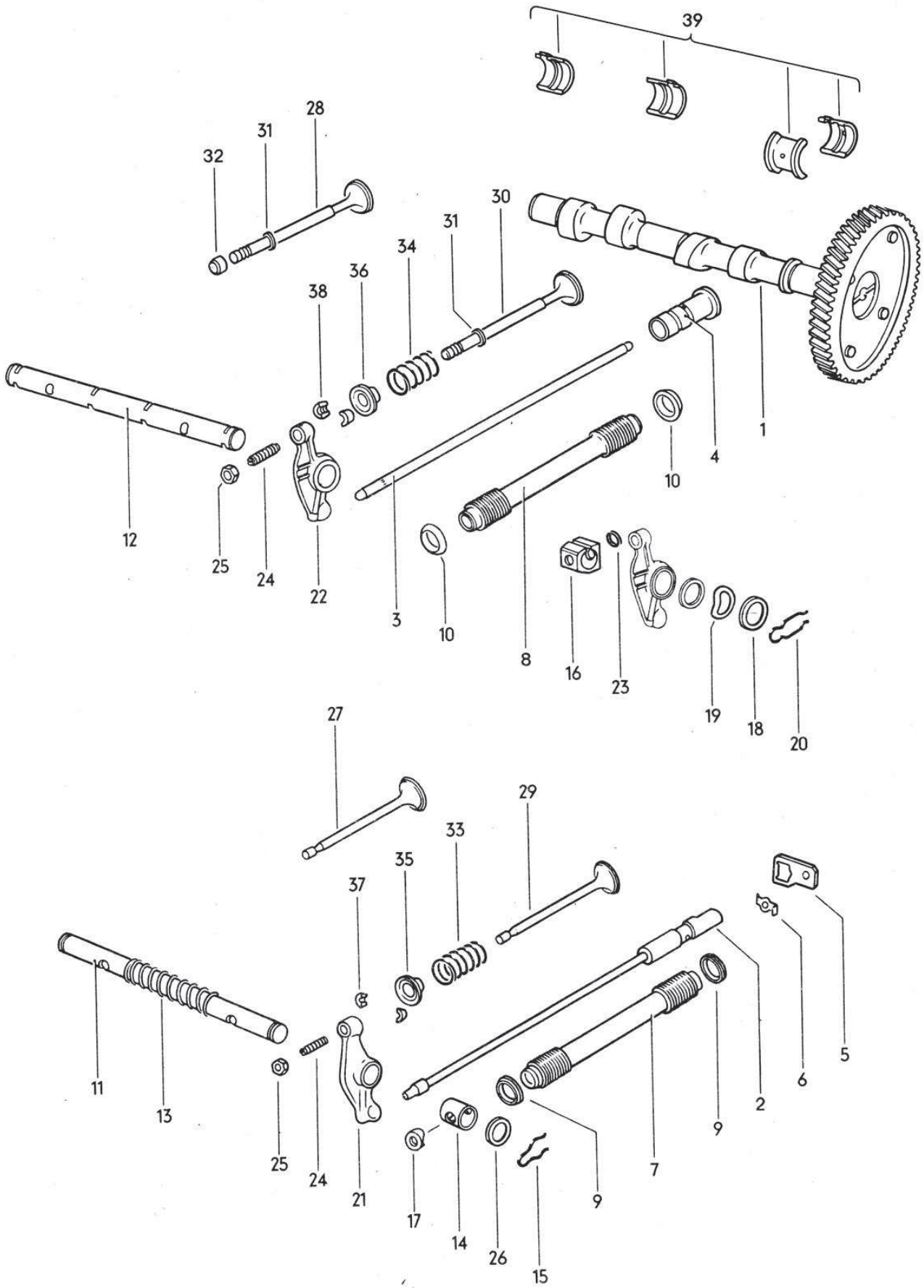

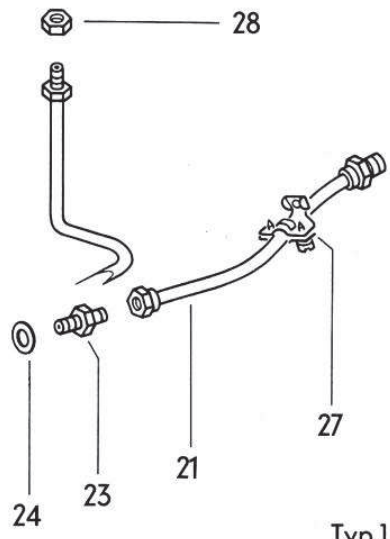
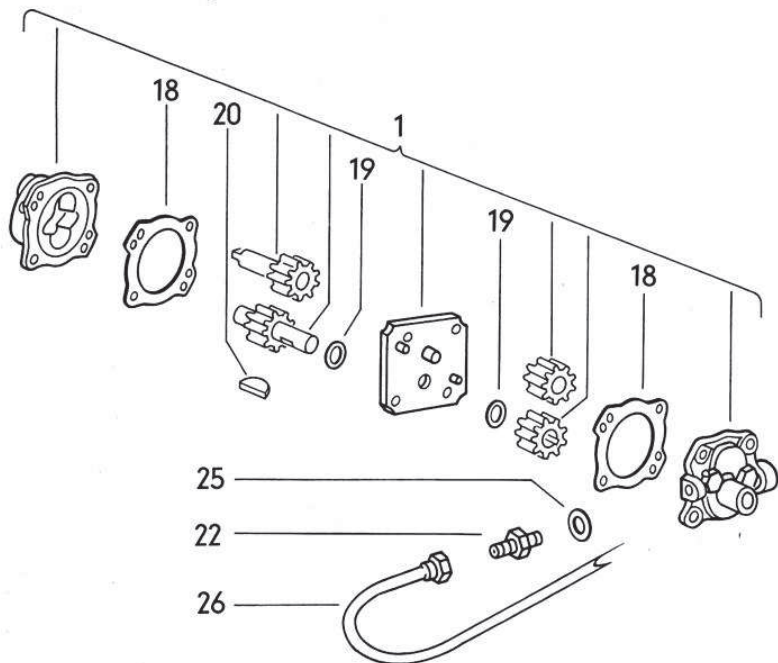
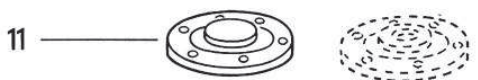
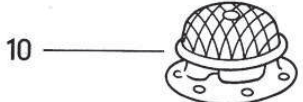
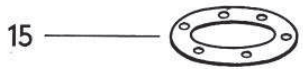
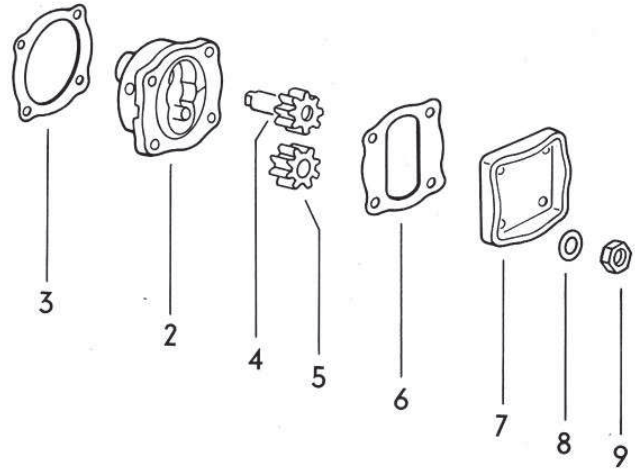
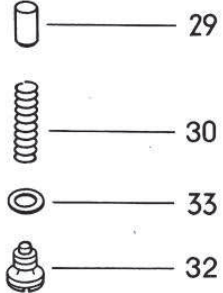
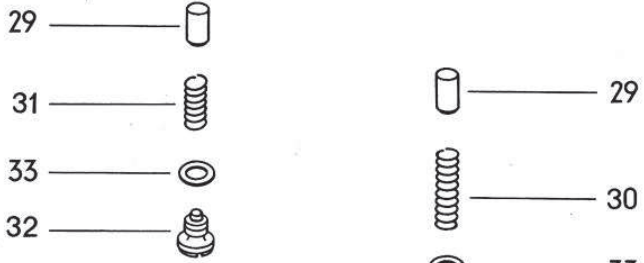
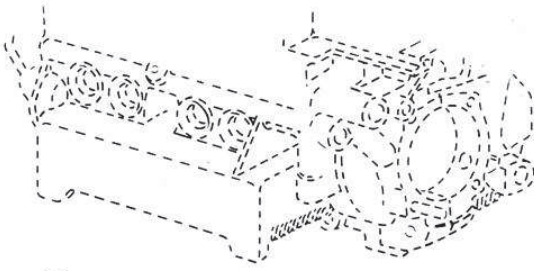

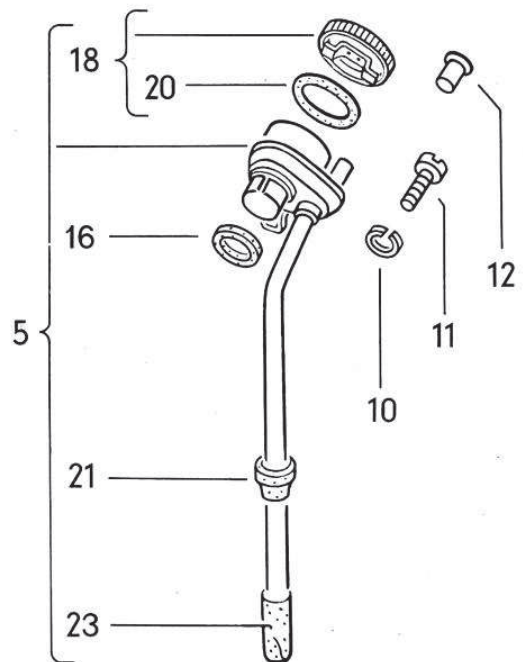
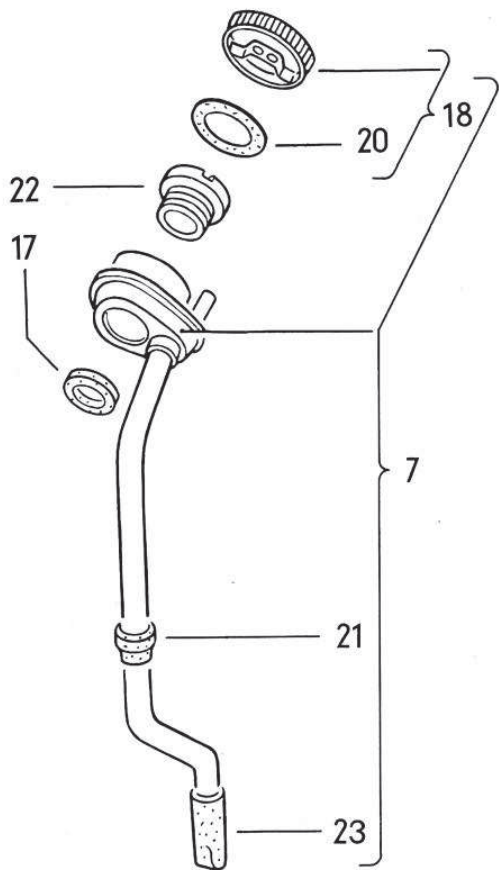
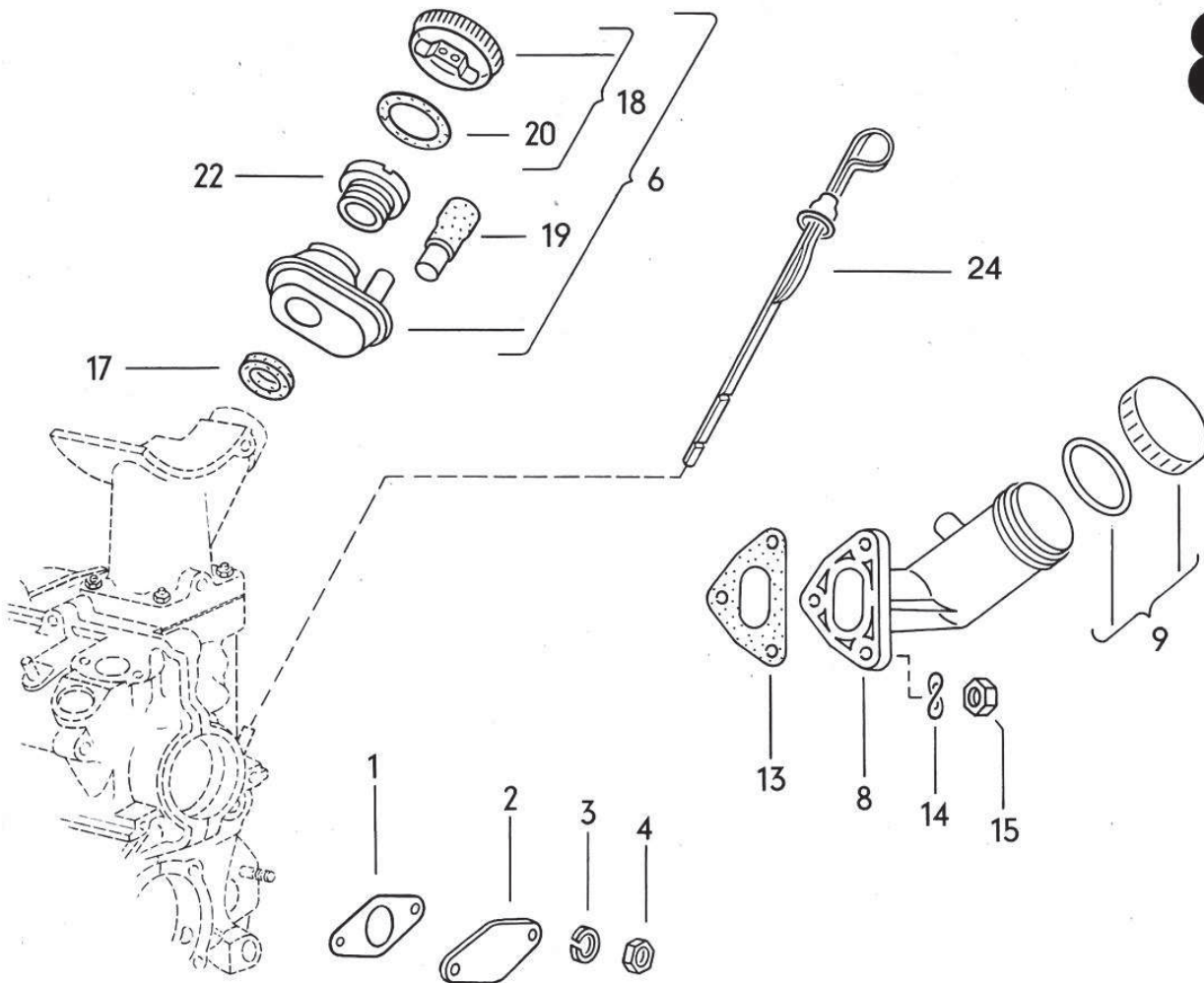

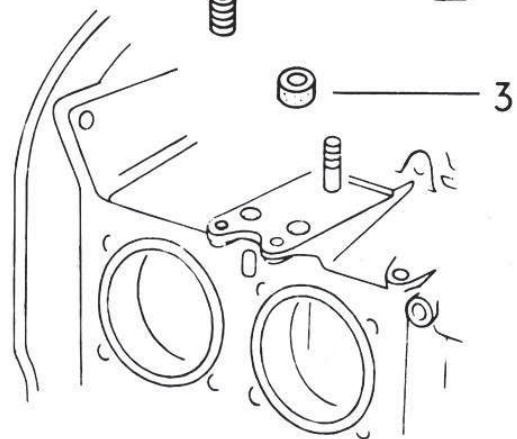
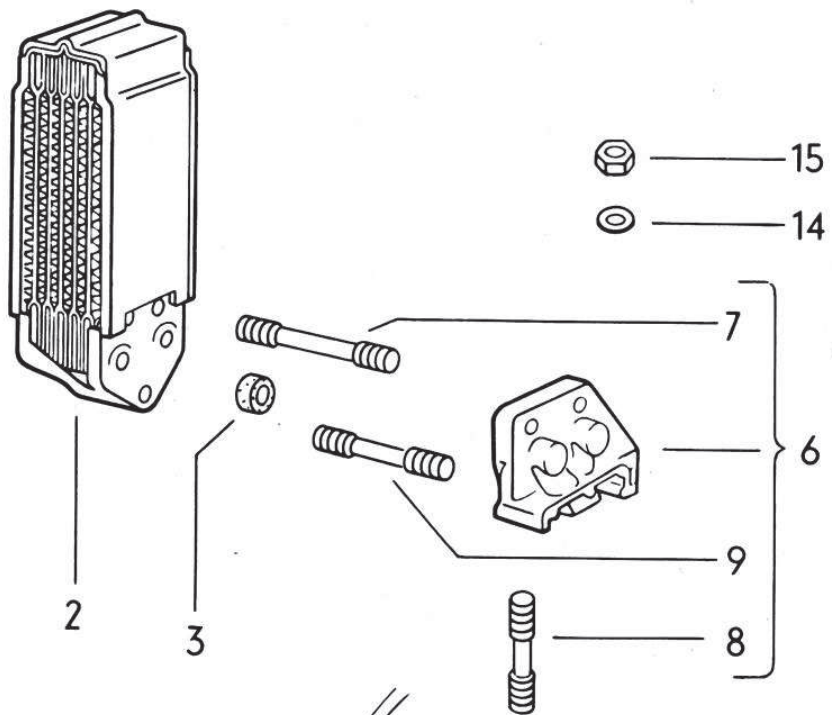
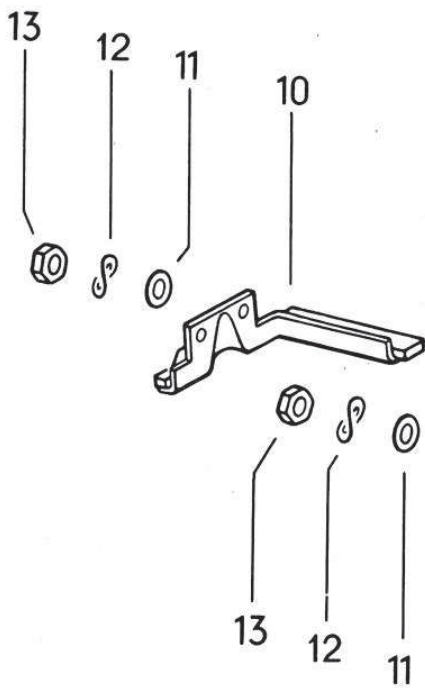
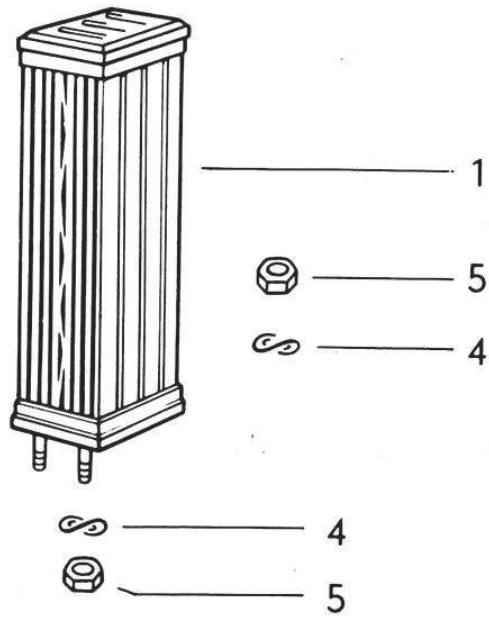

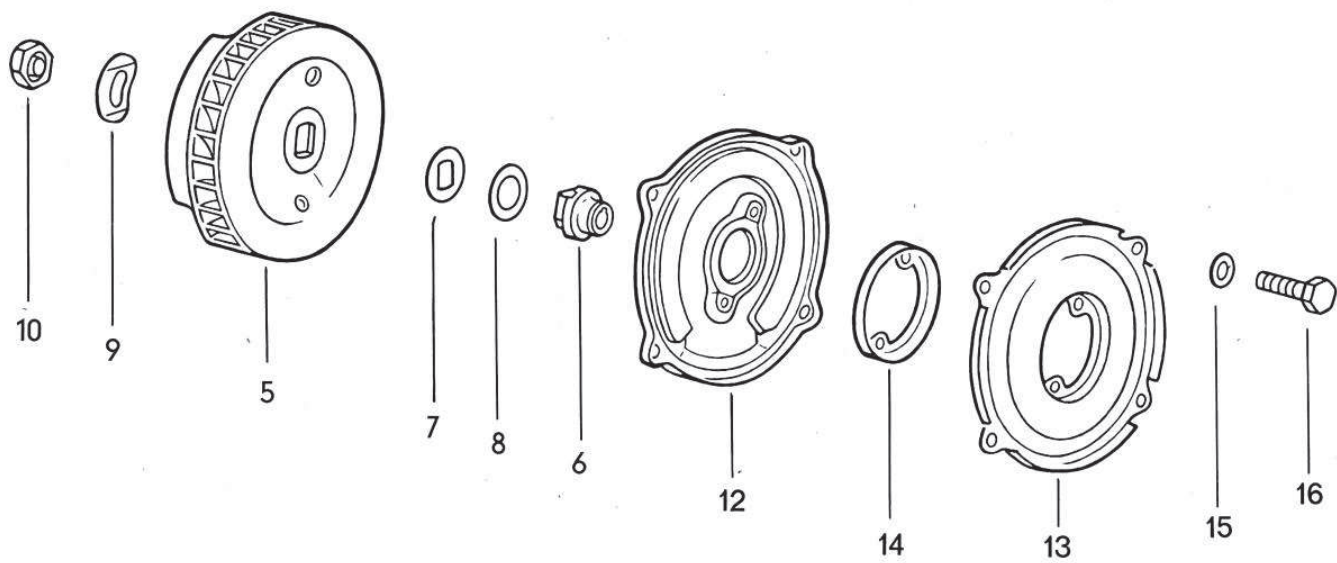
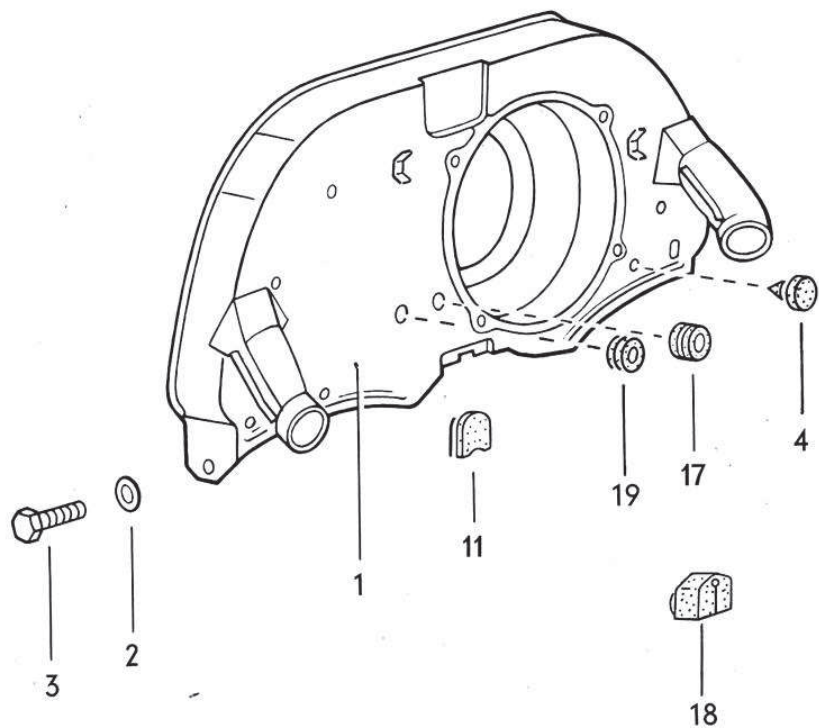

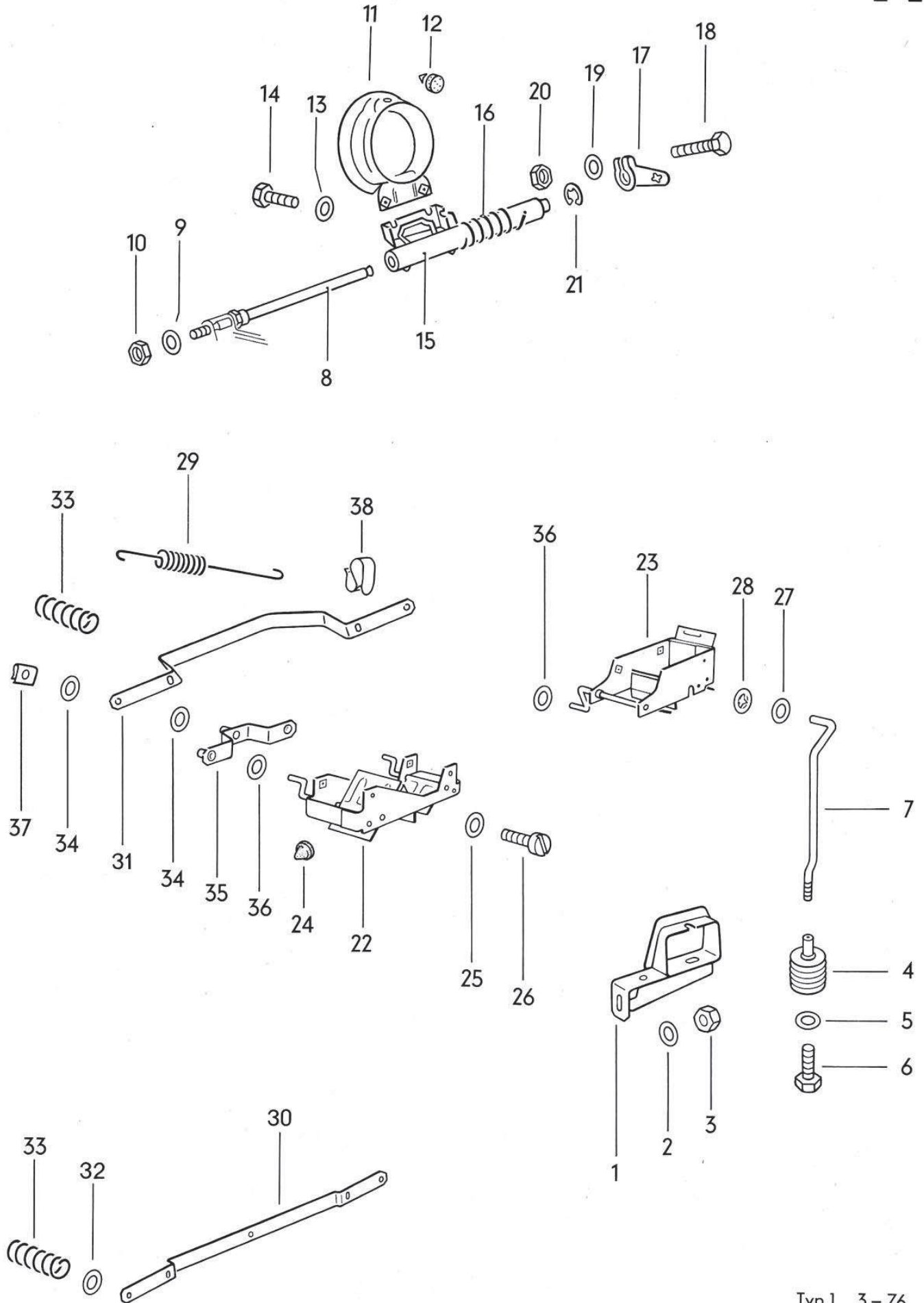

12

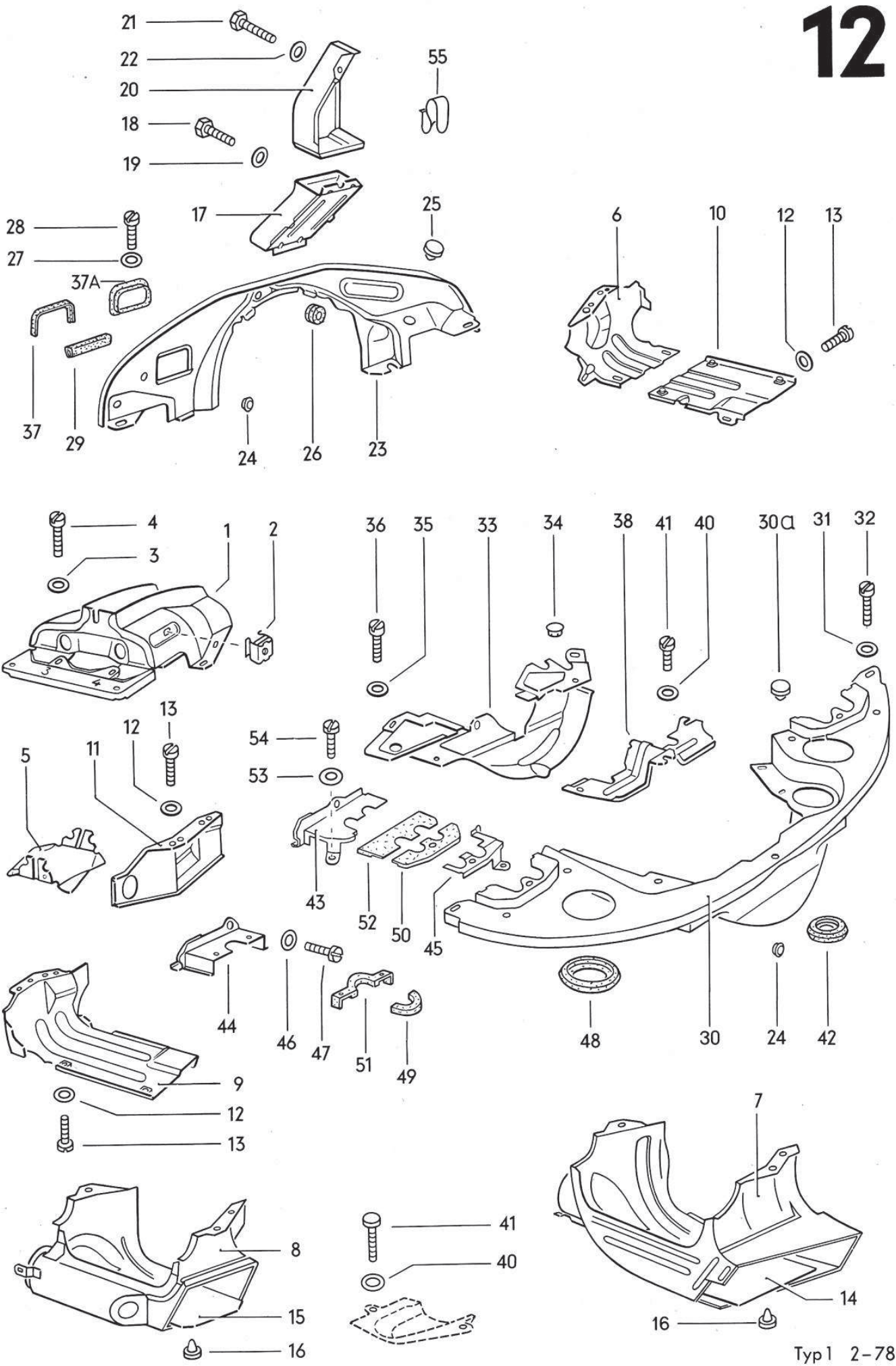

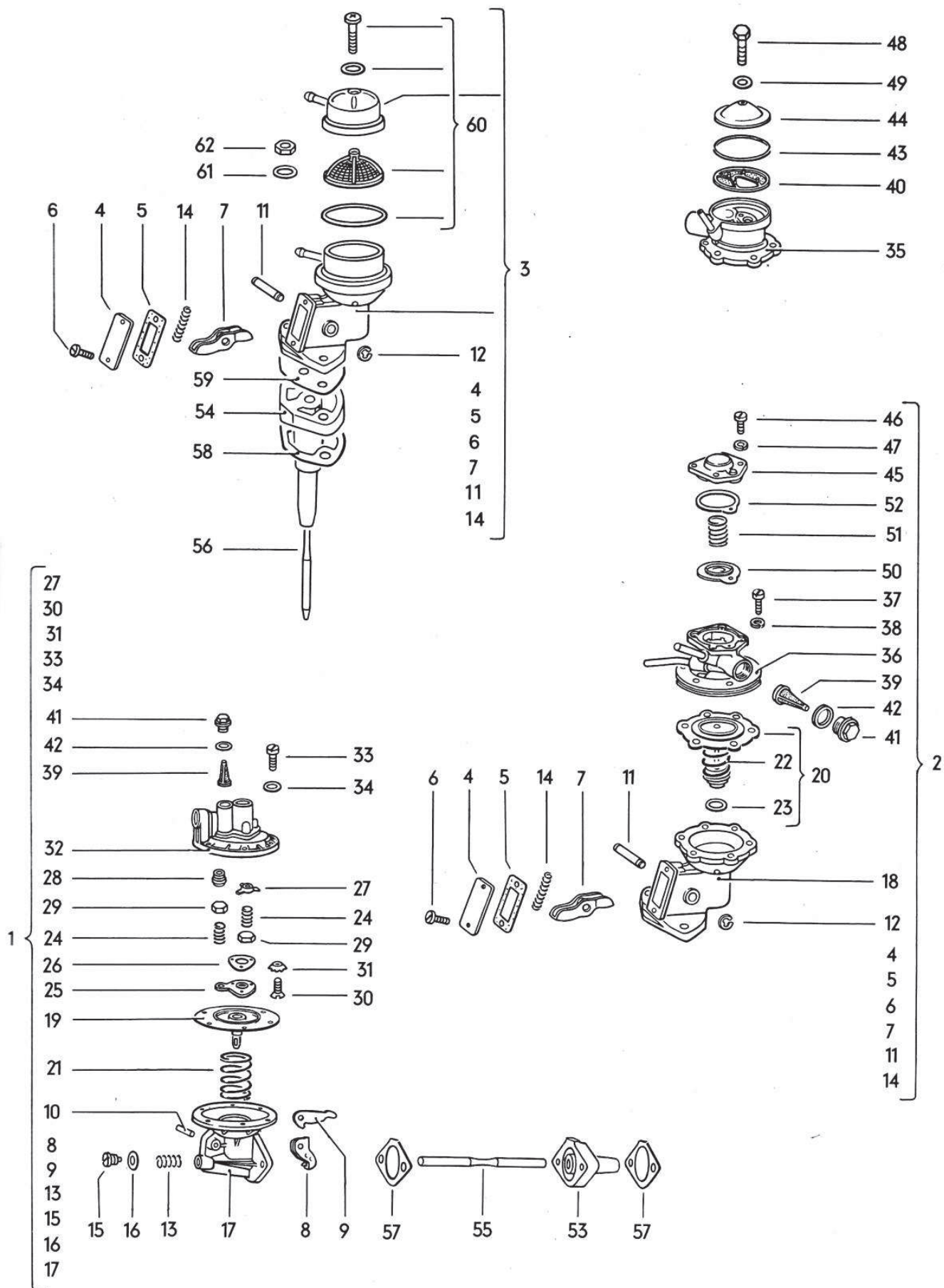

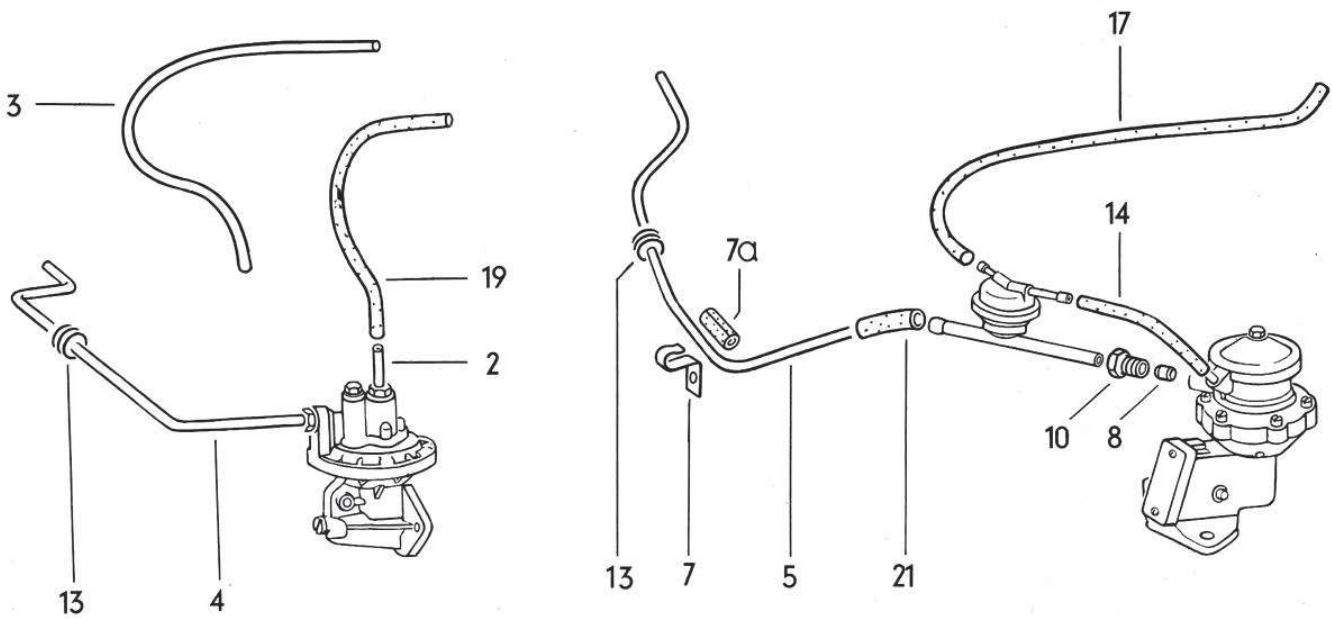
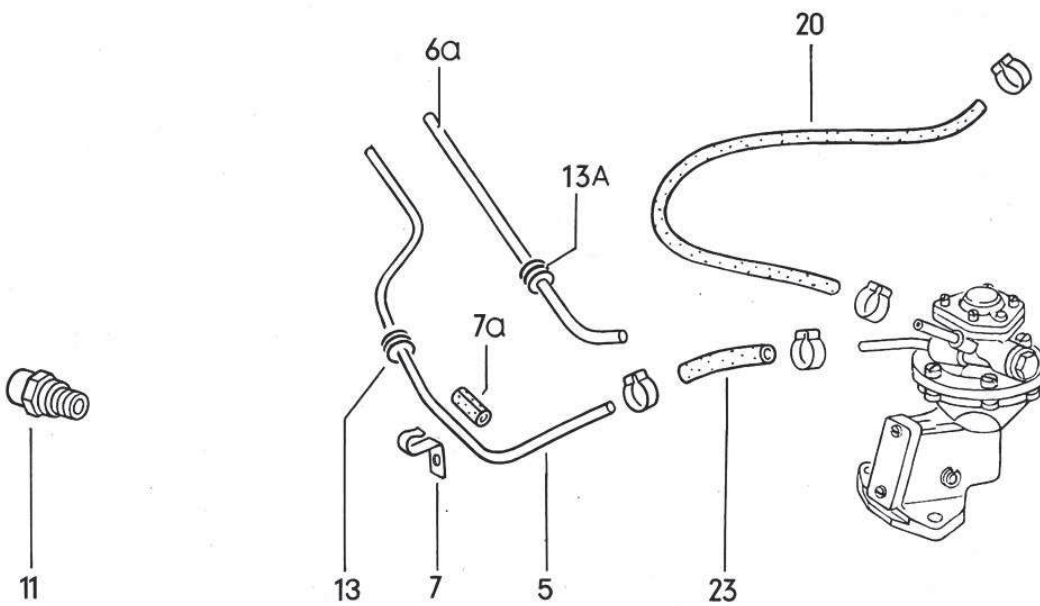
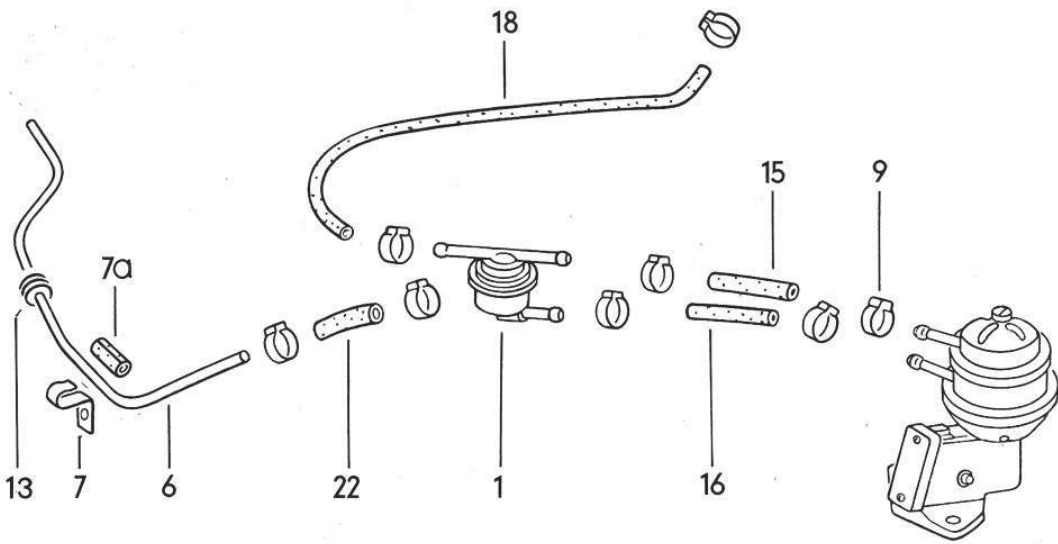

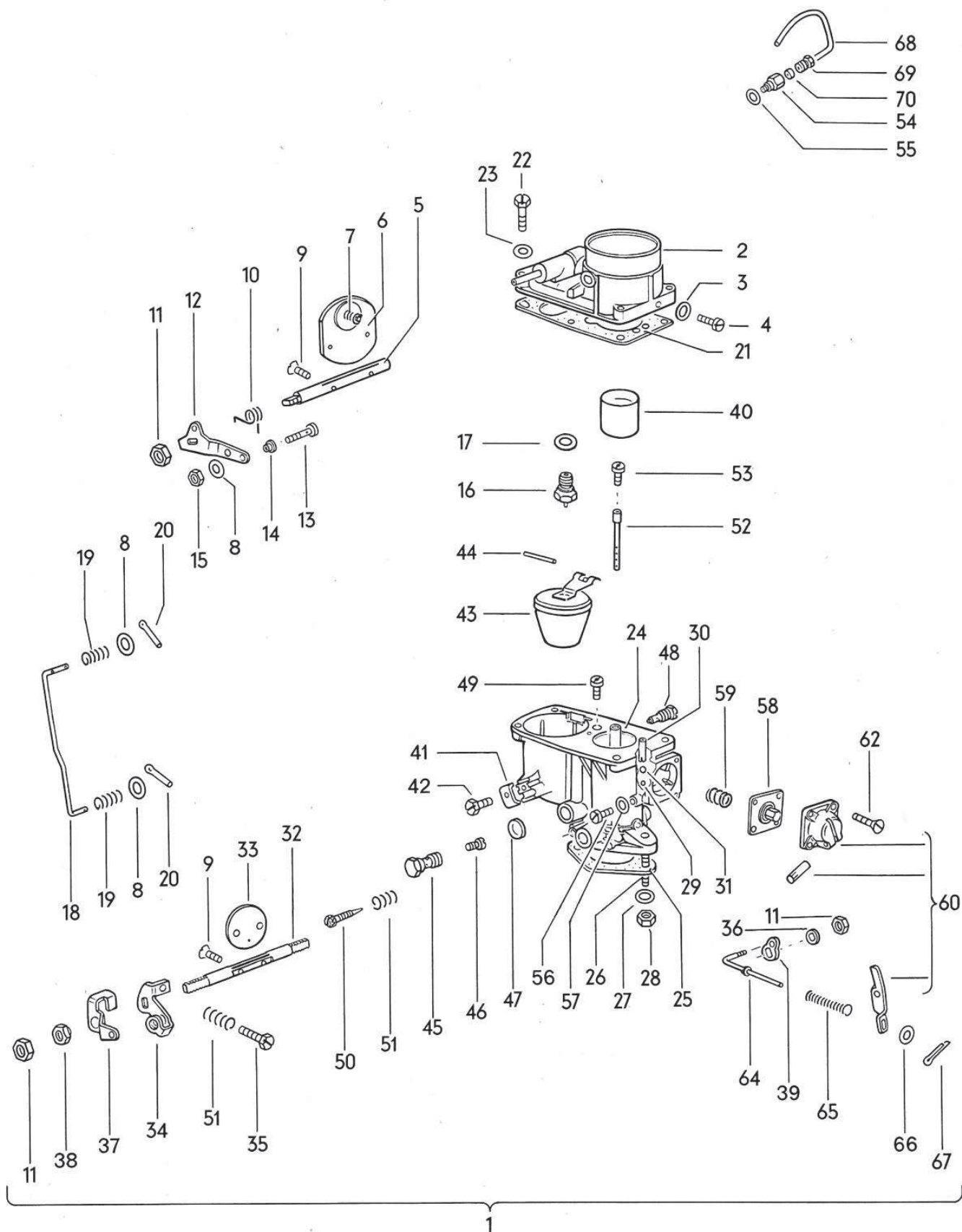

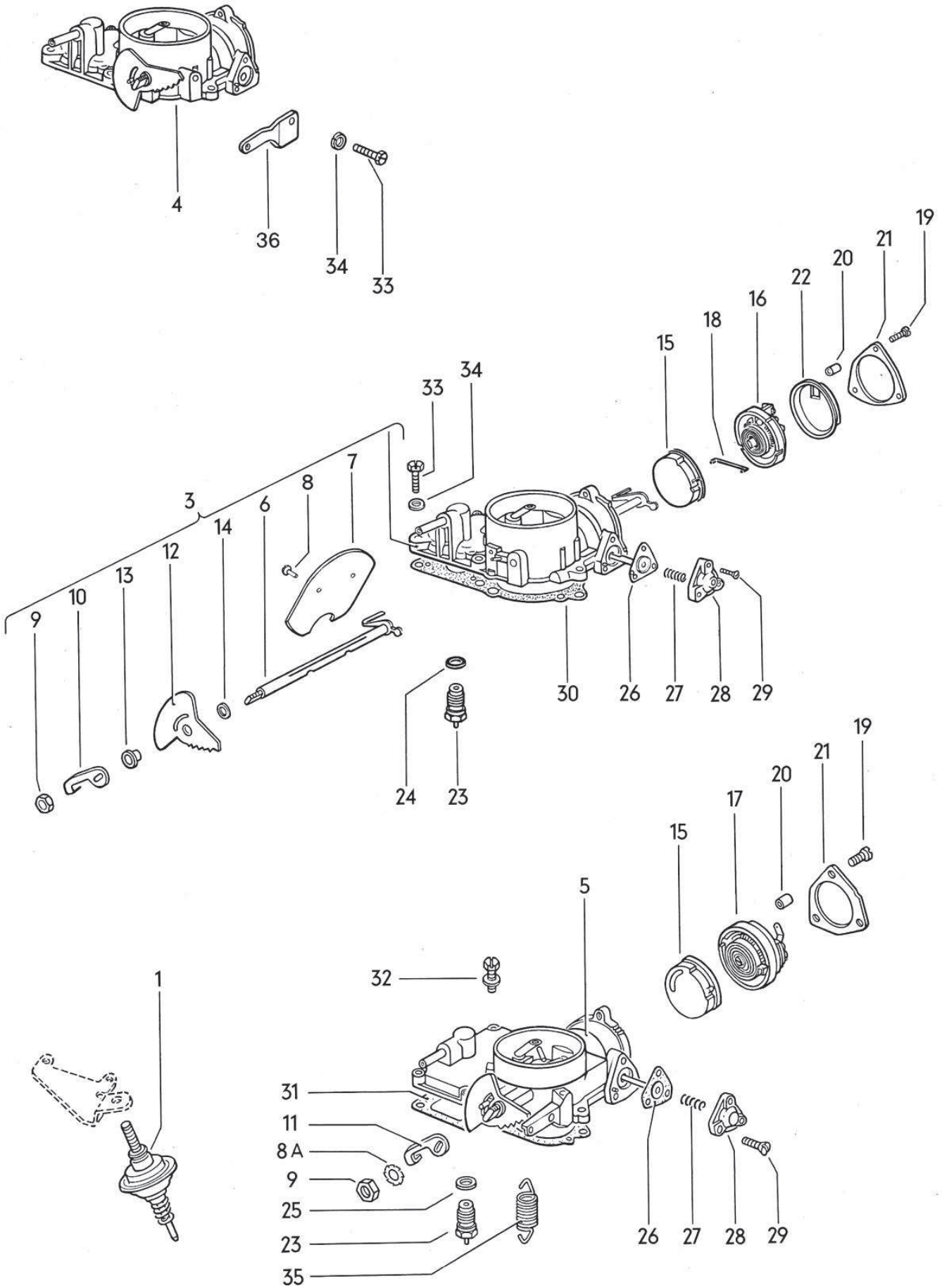

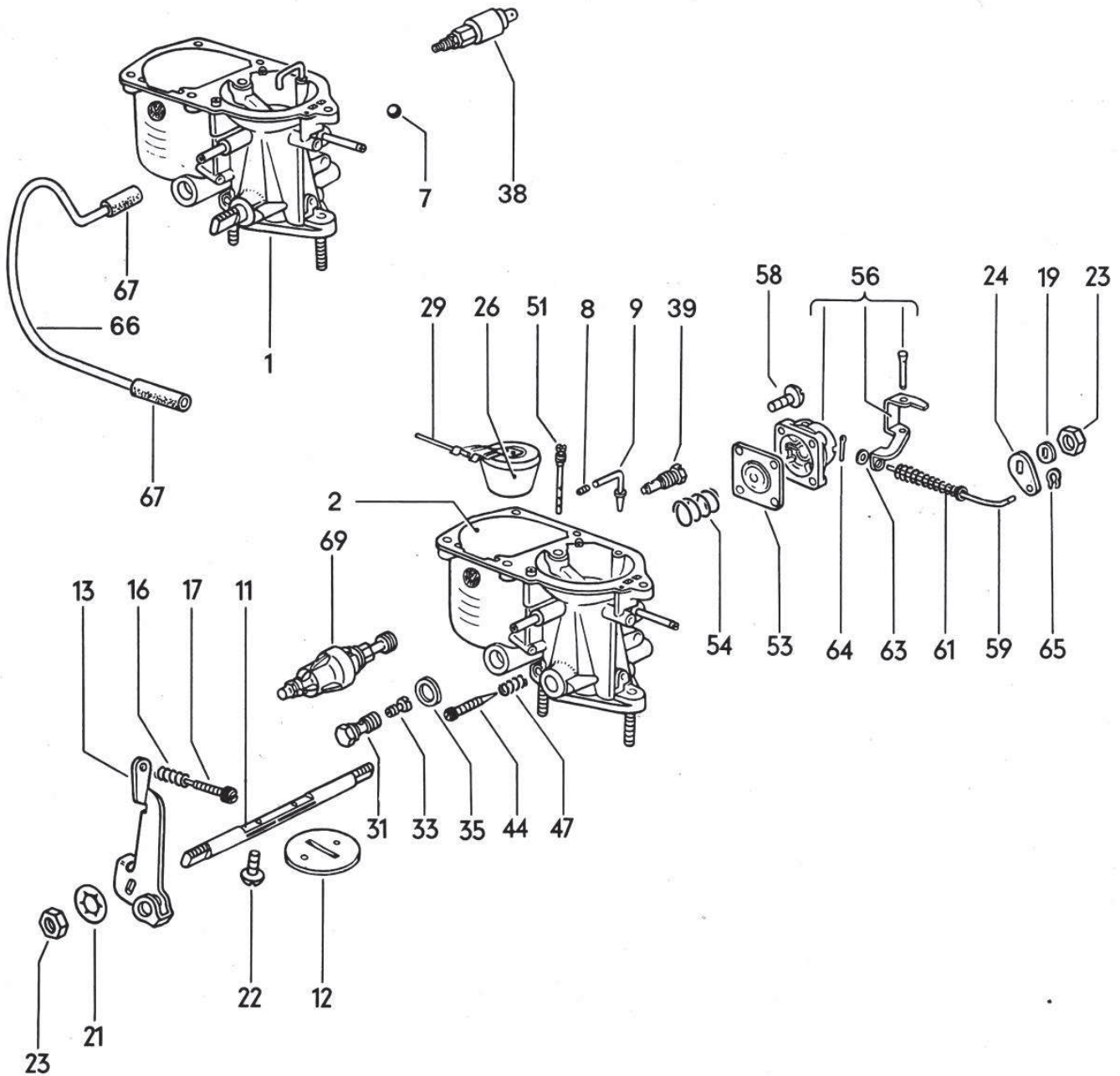

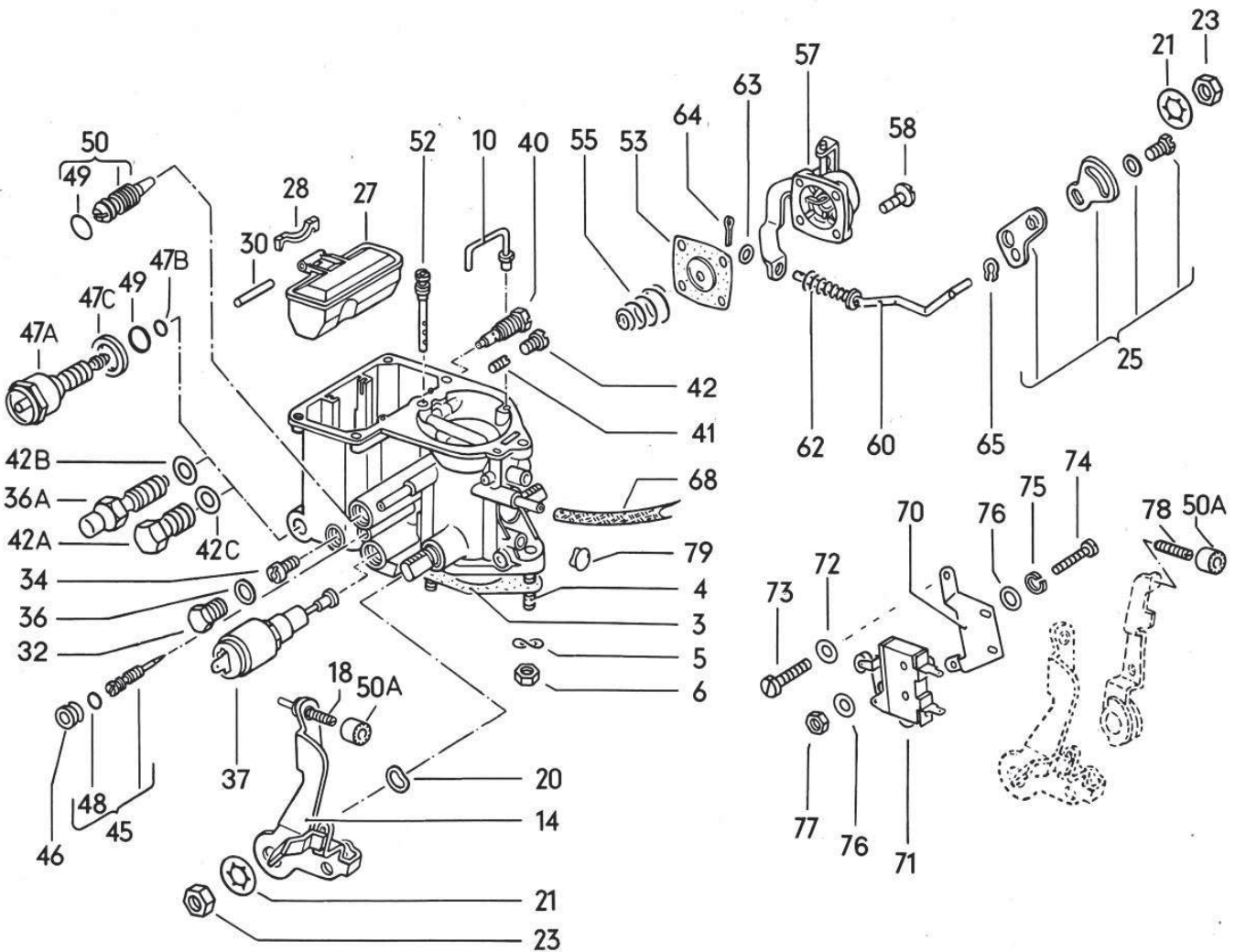
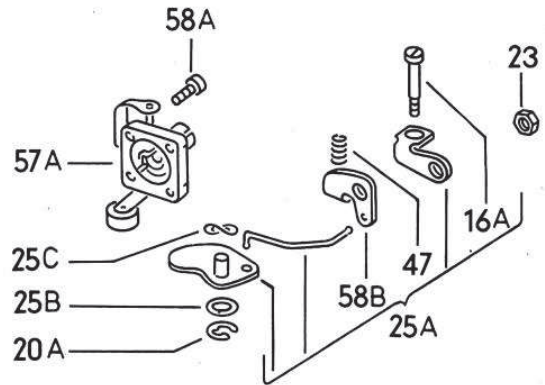

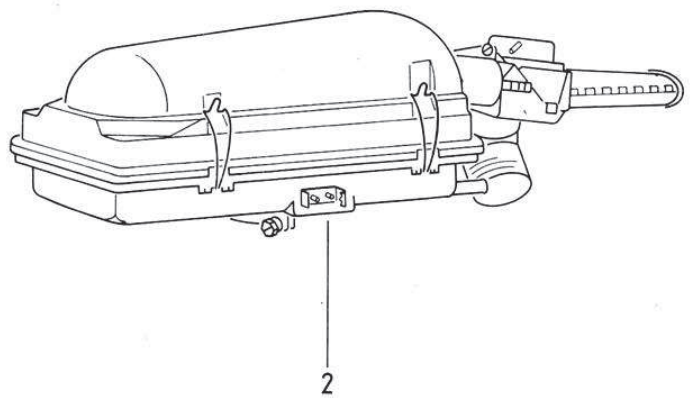
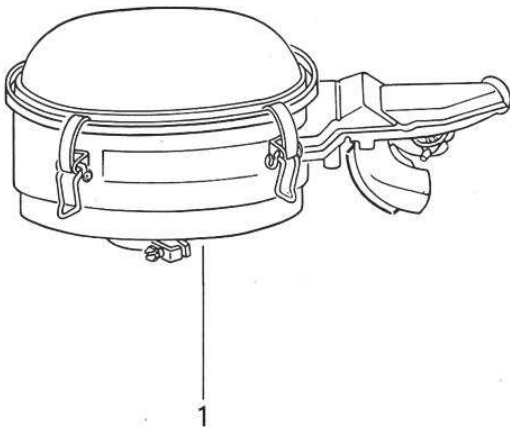
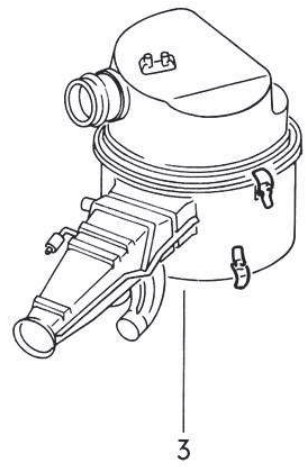
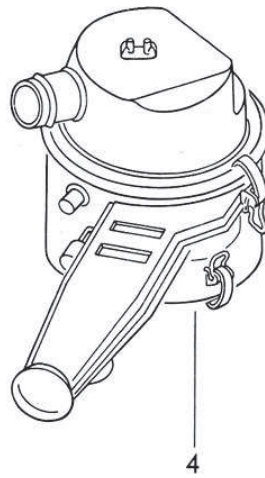
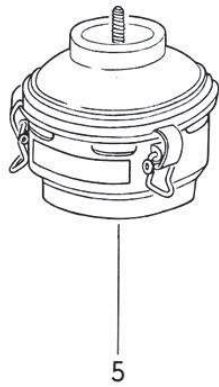
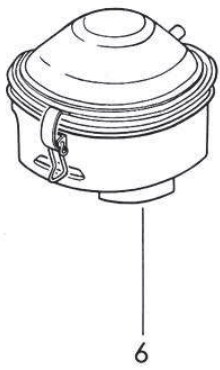
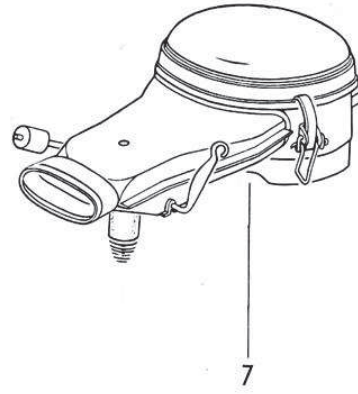
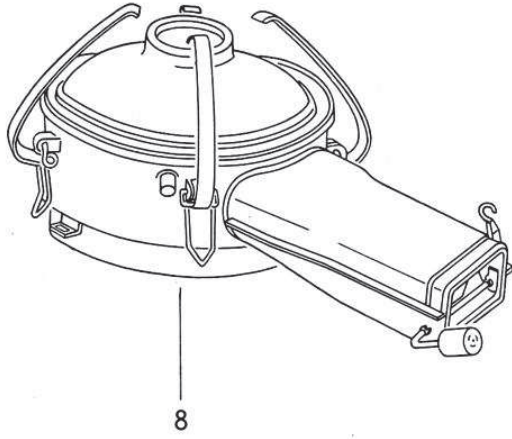

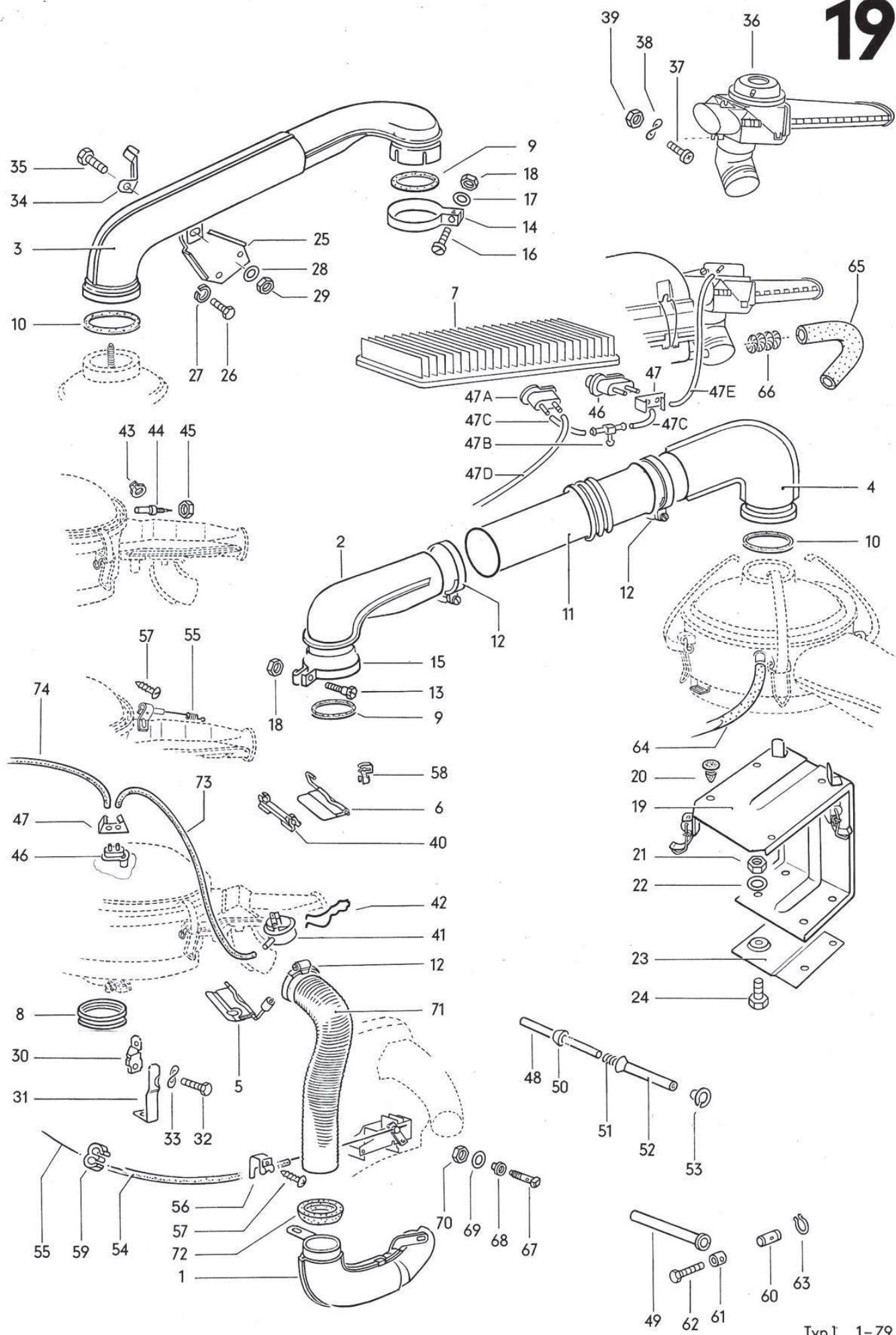

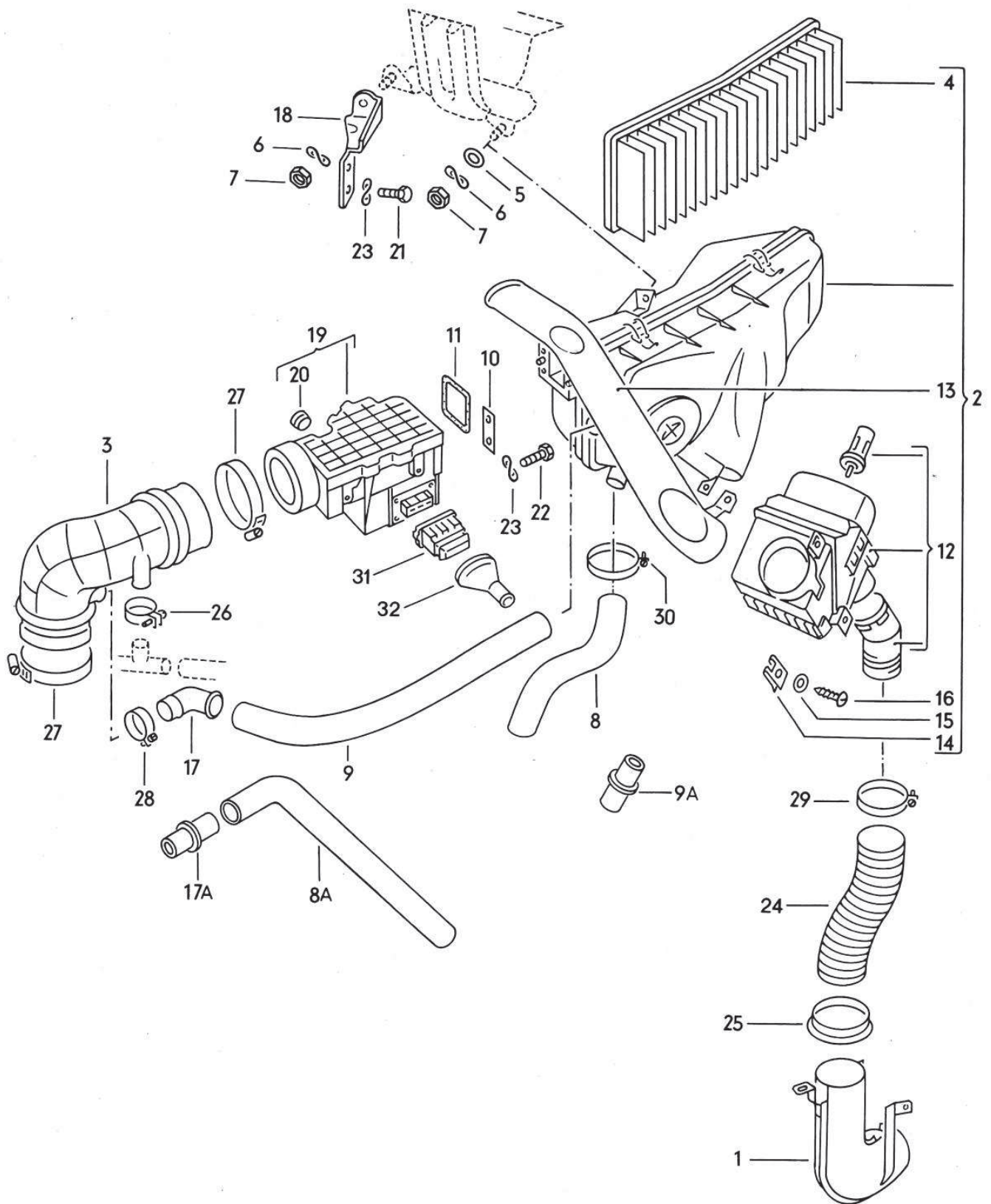

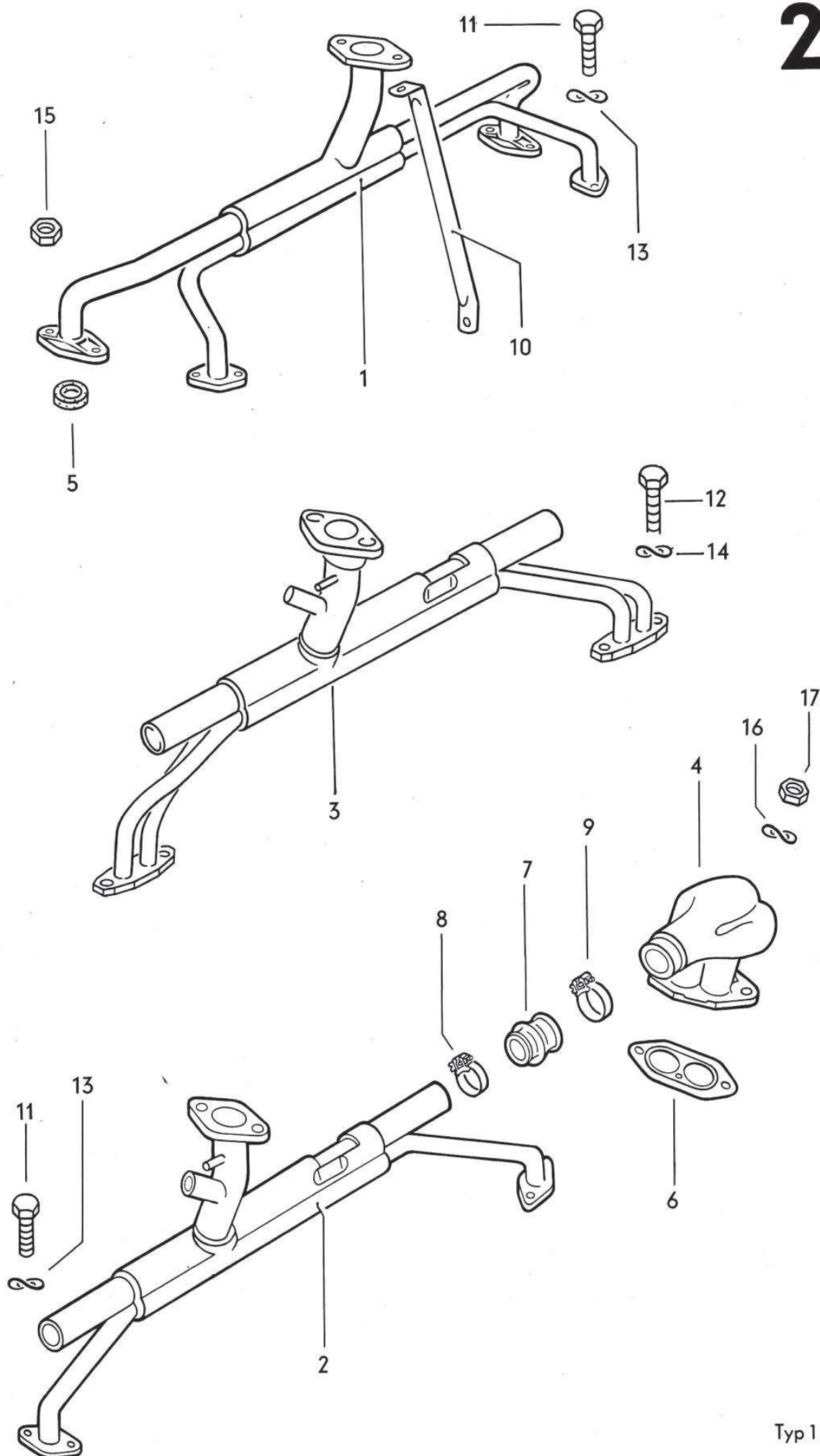

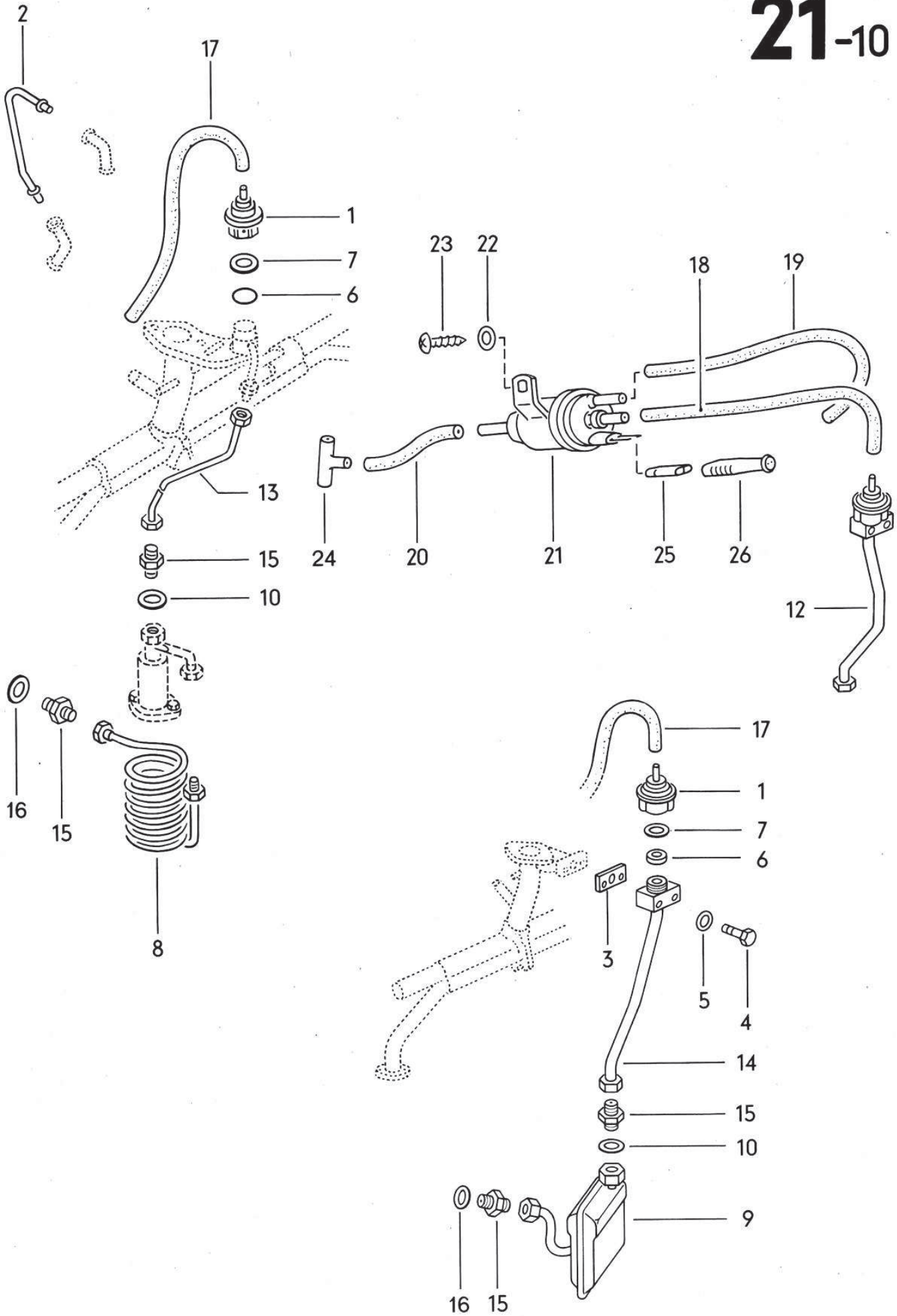

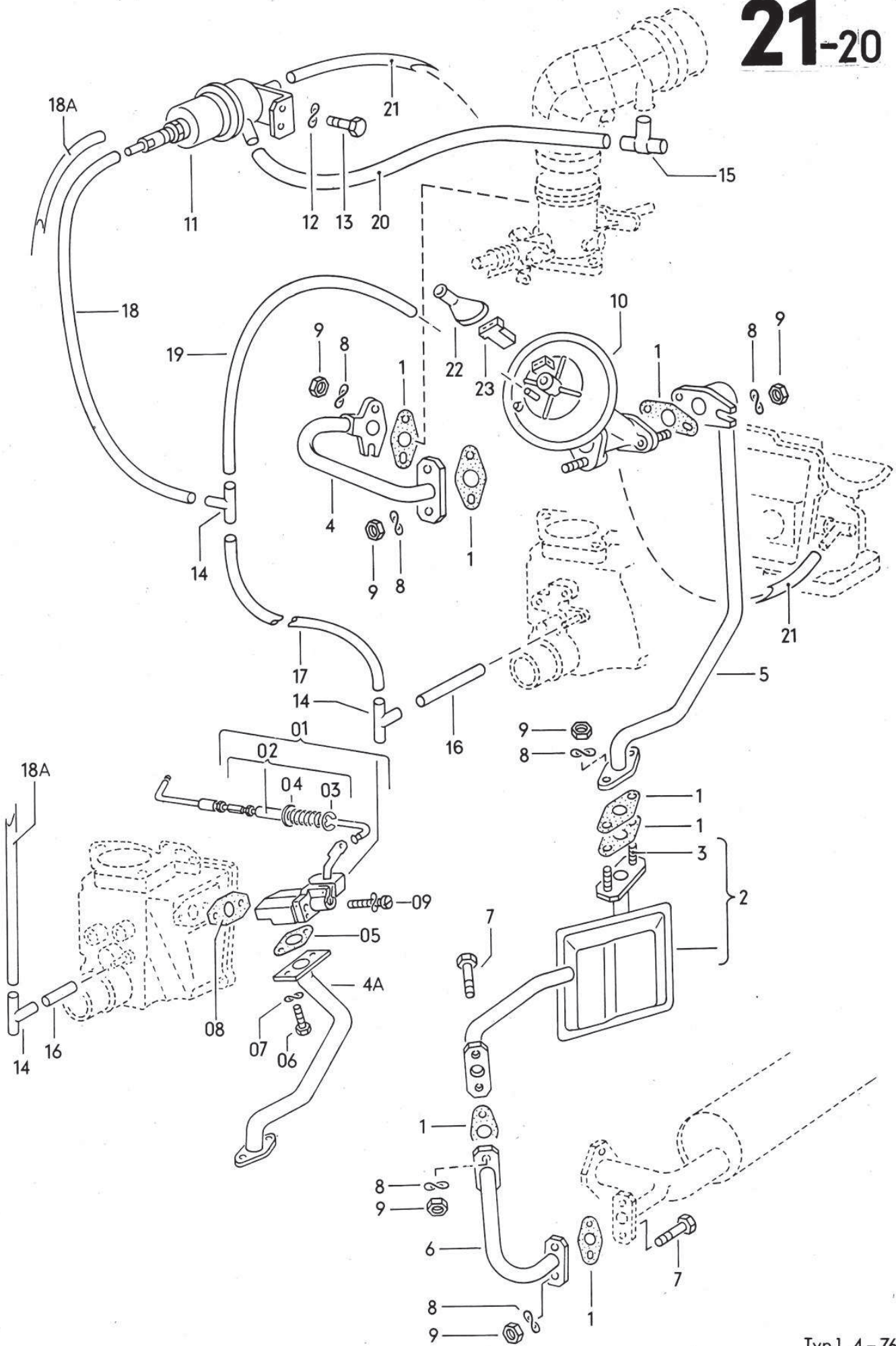

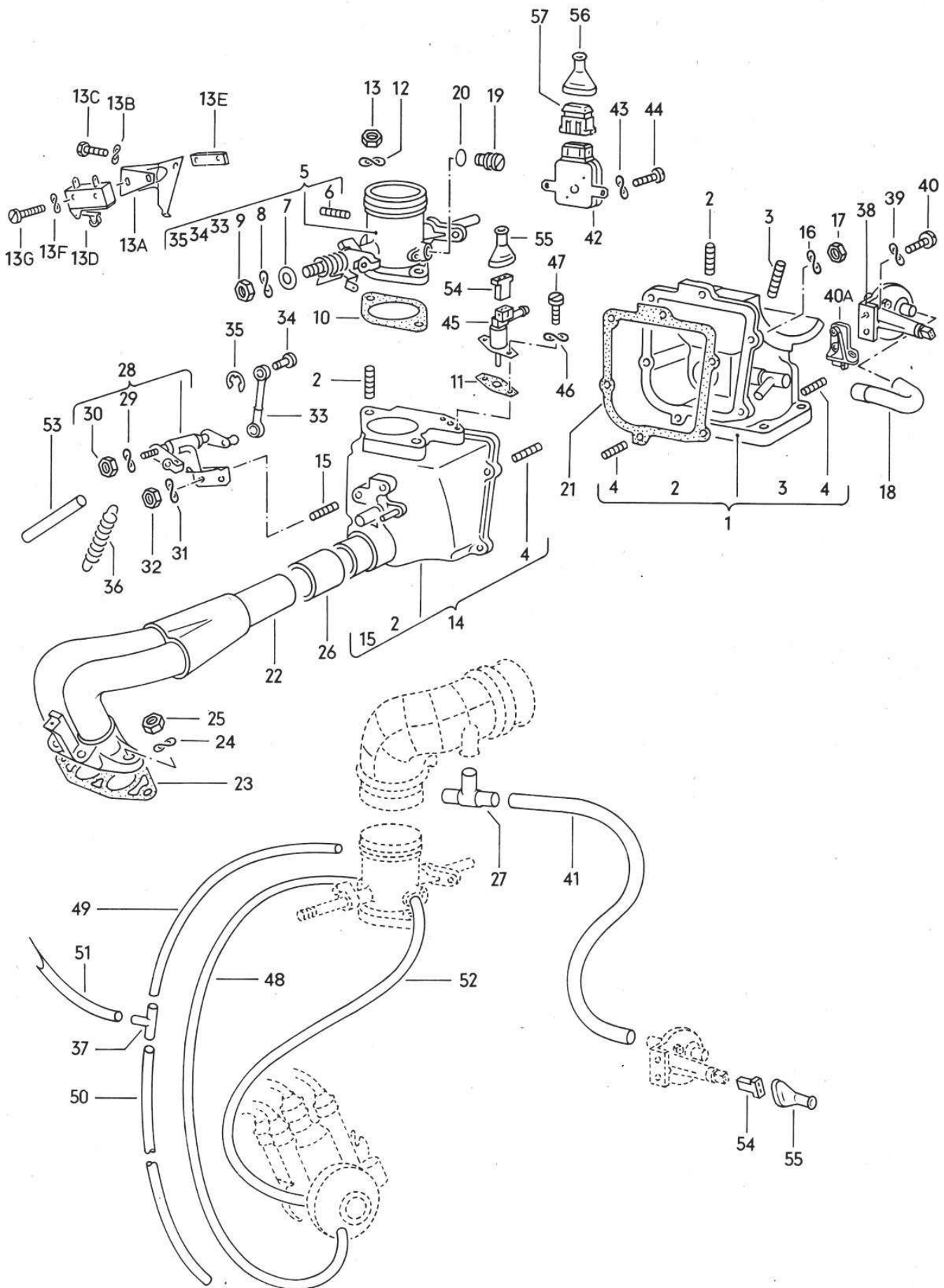

21-40

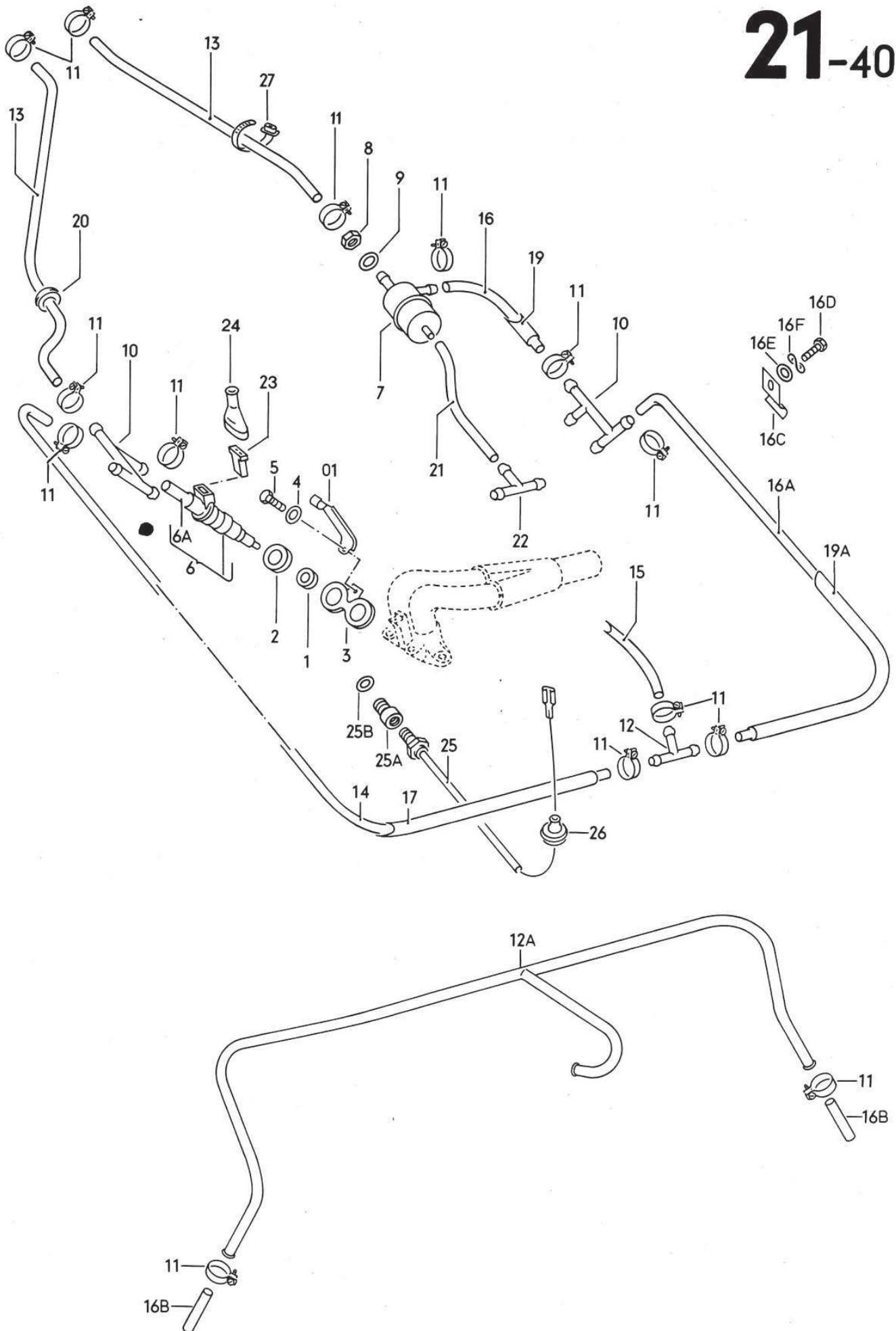

21-50

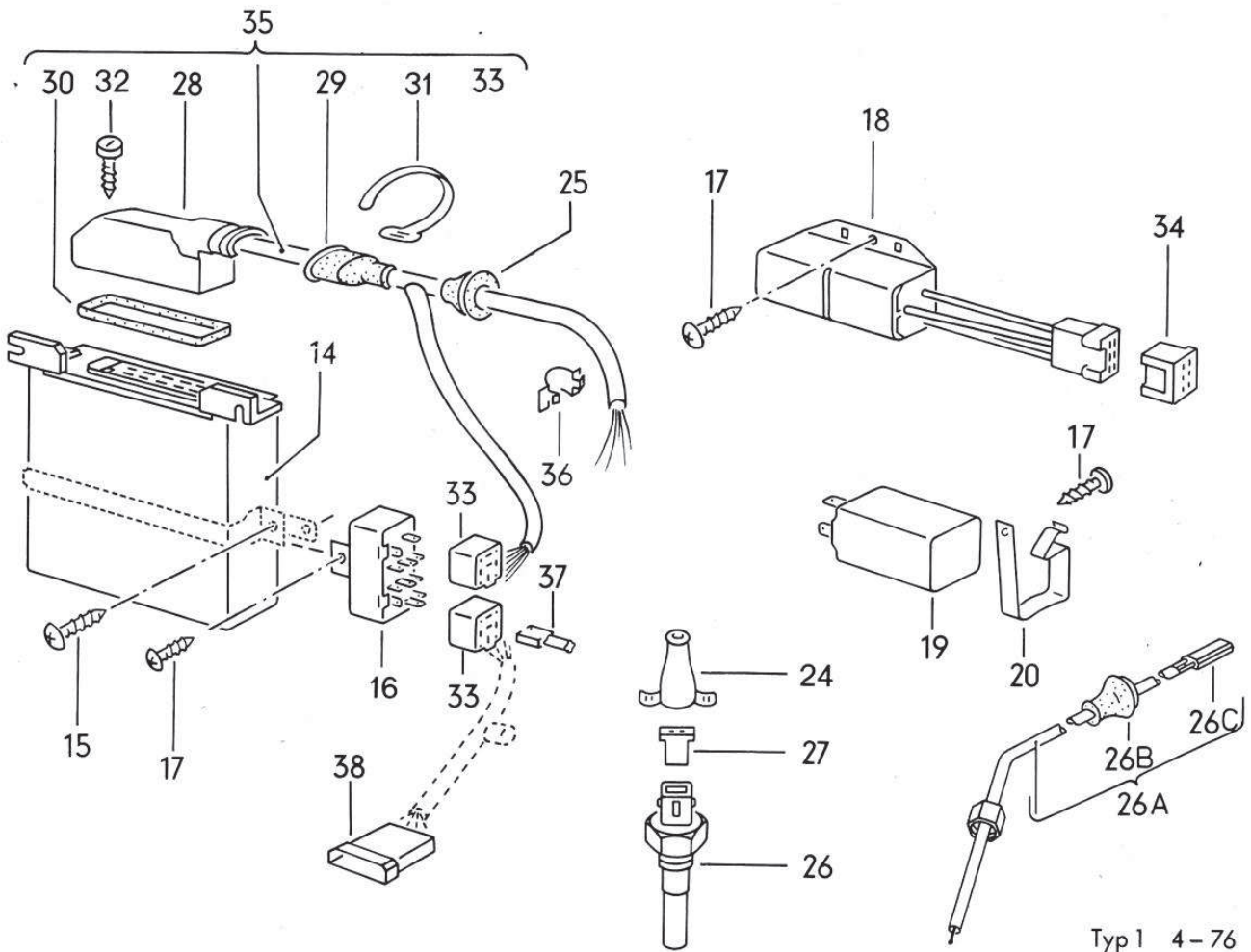
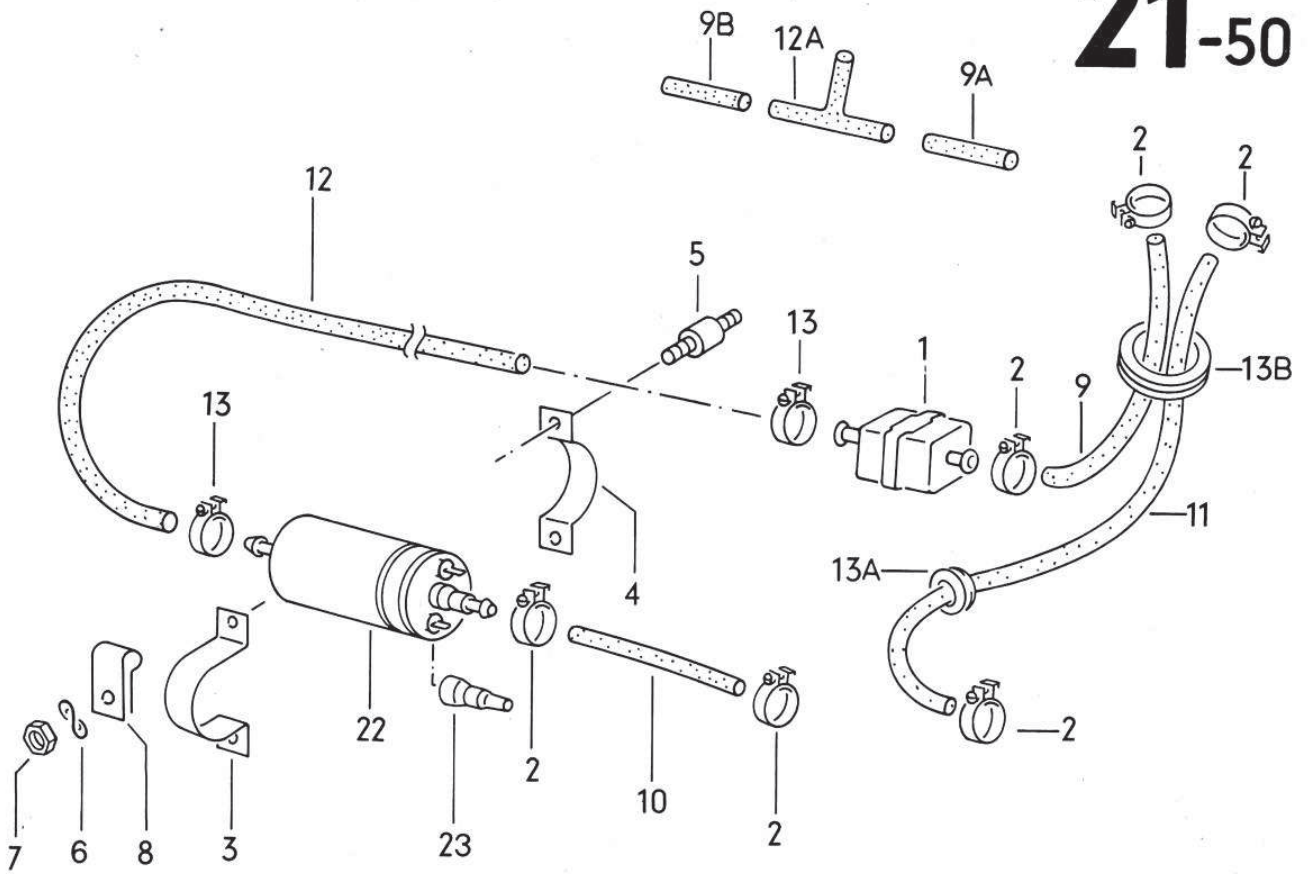

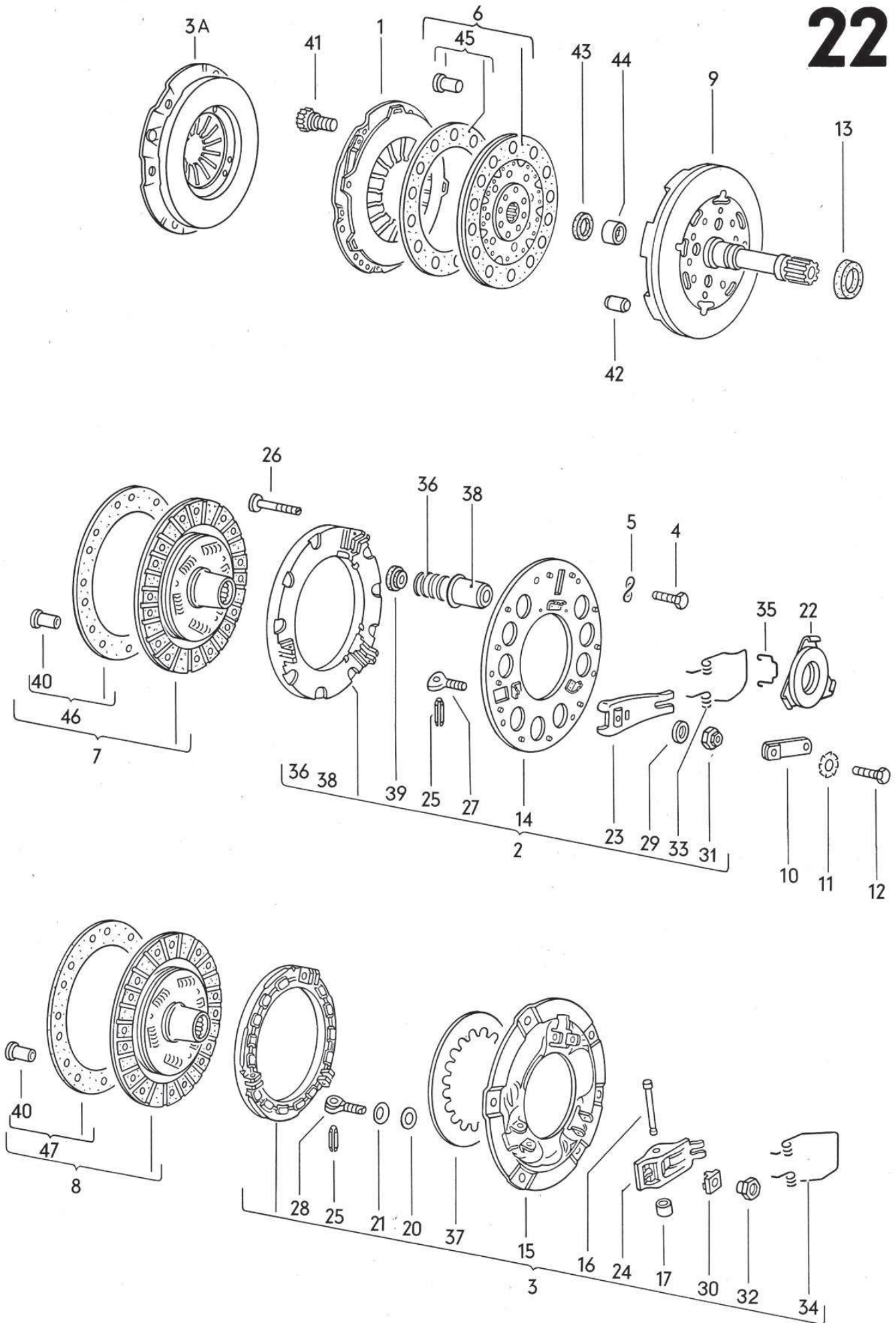

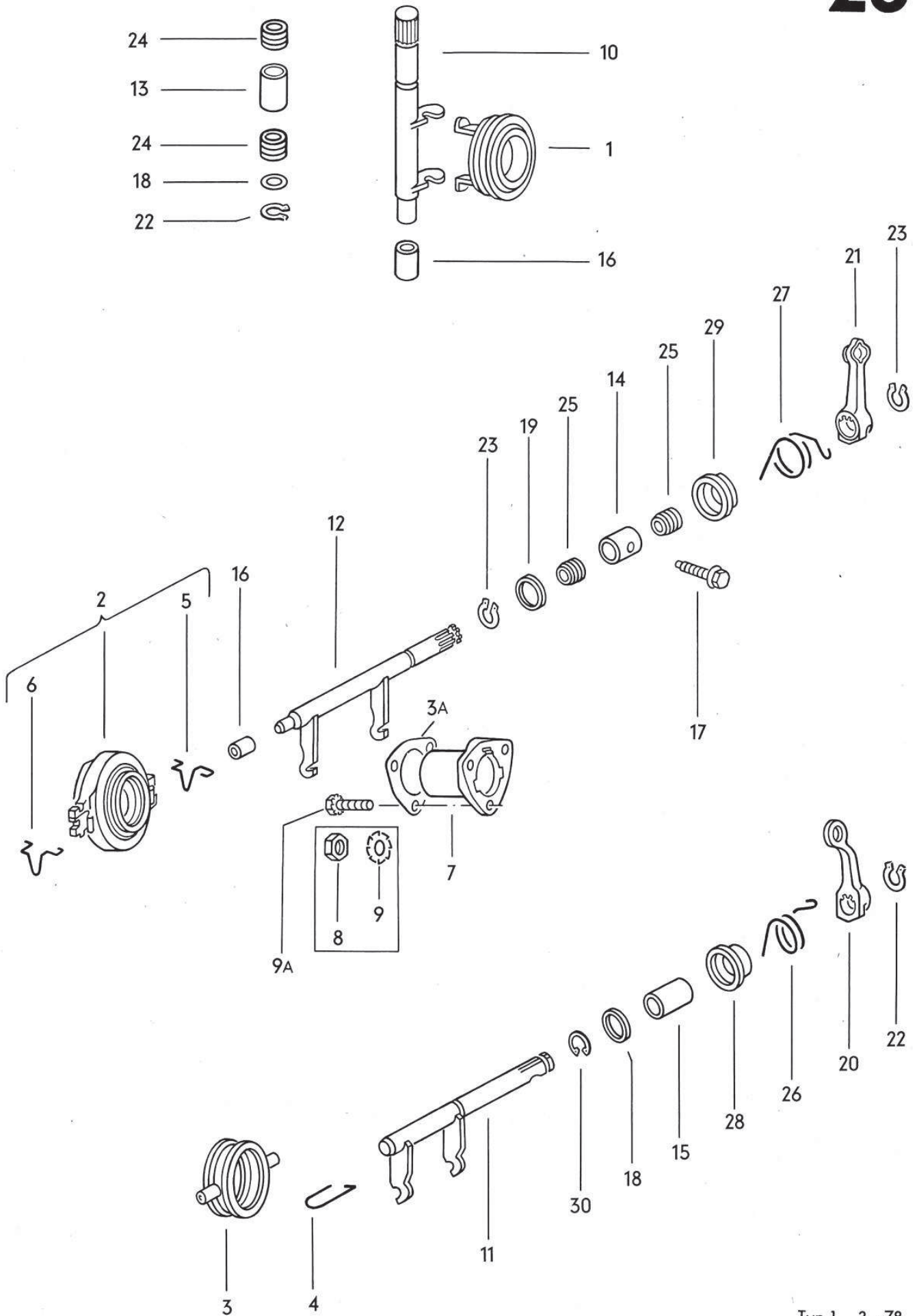

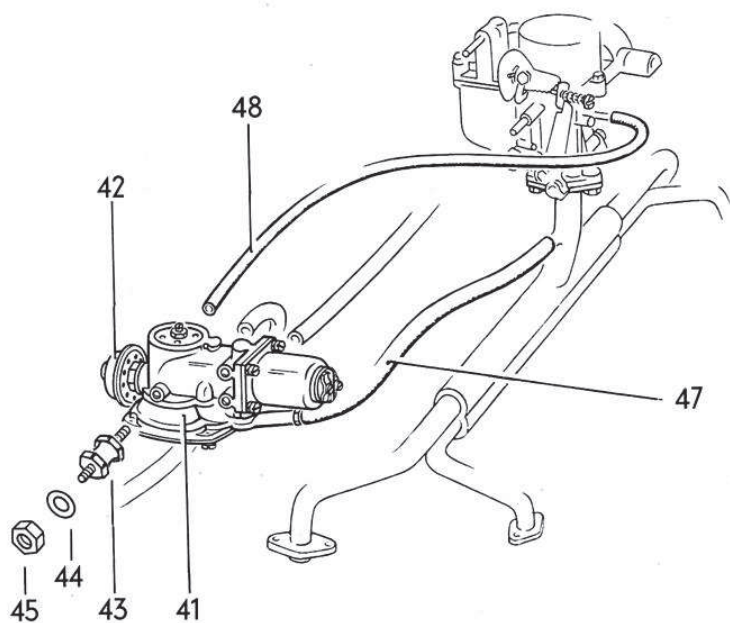
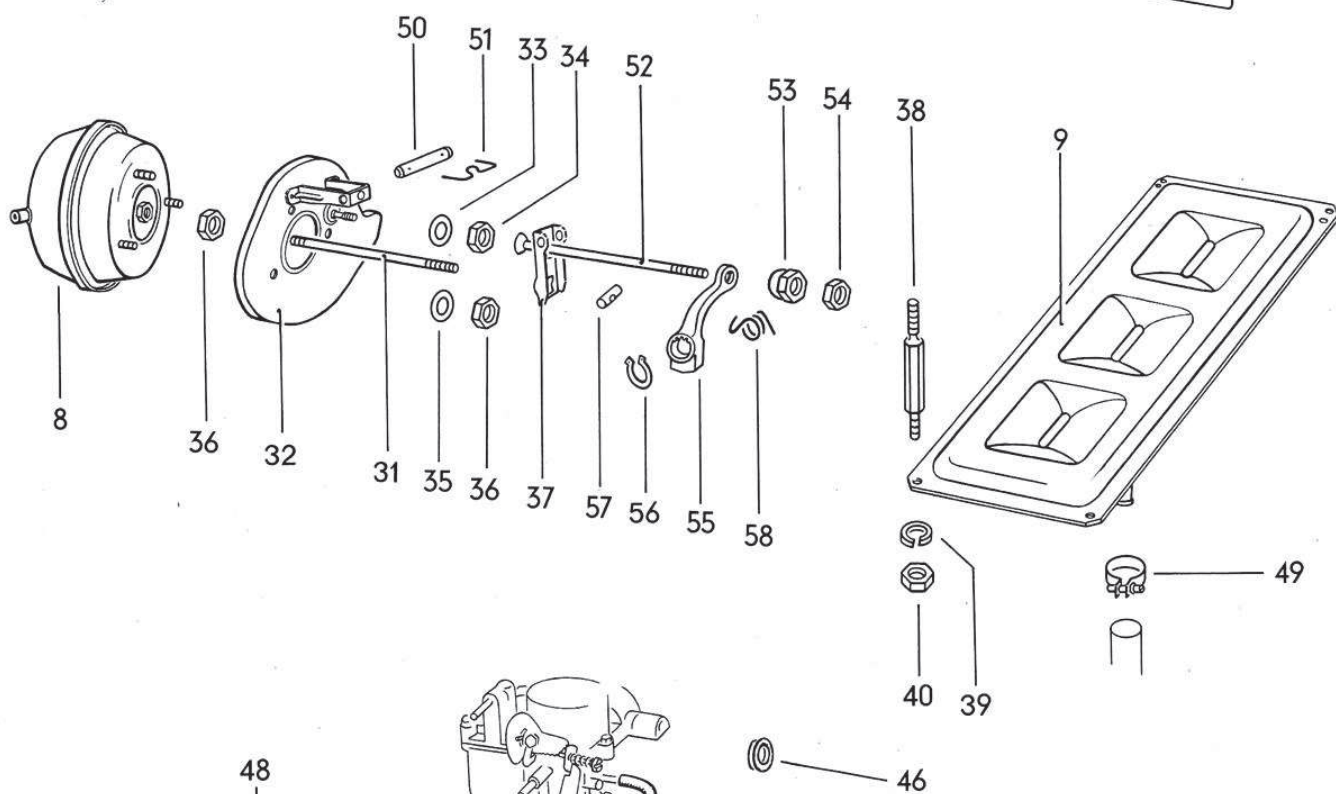
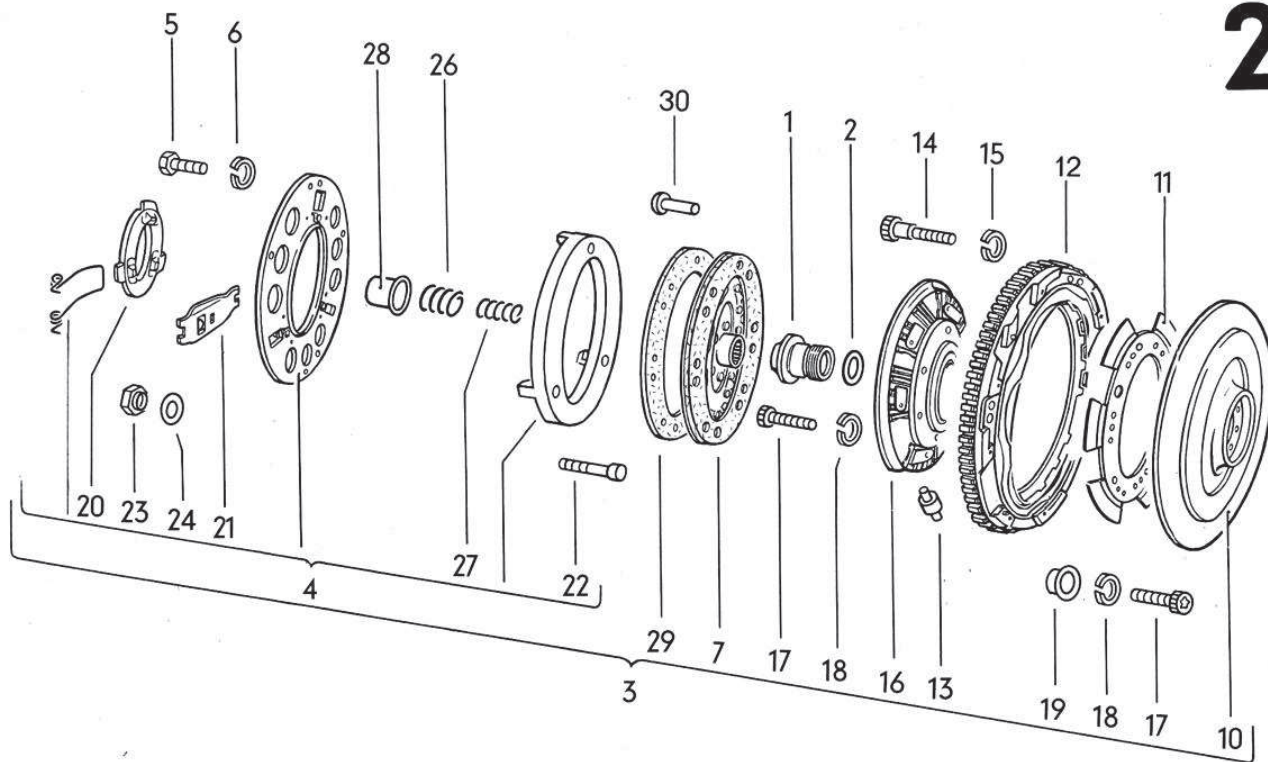

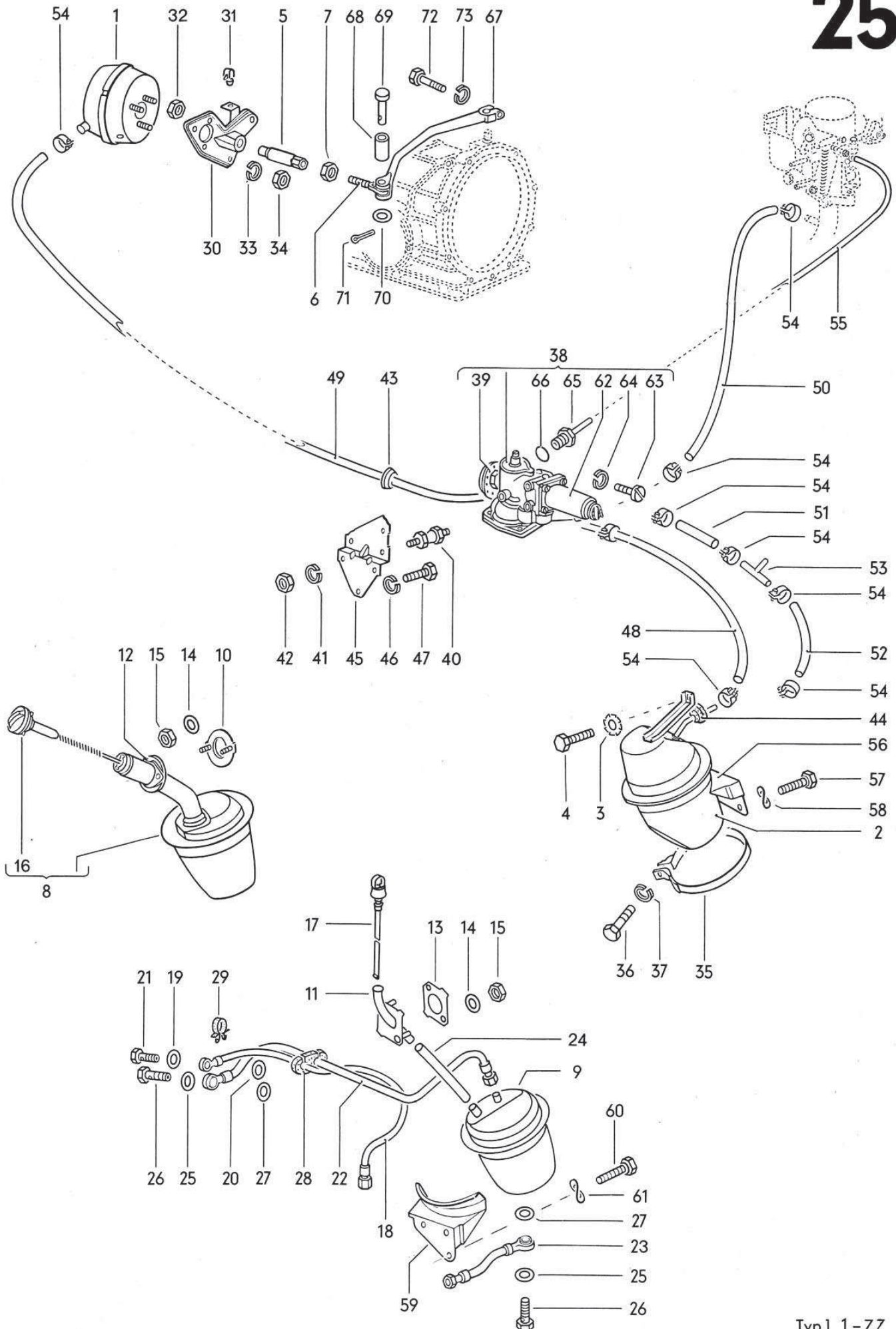

25-10

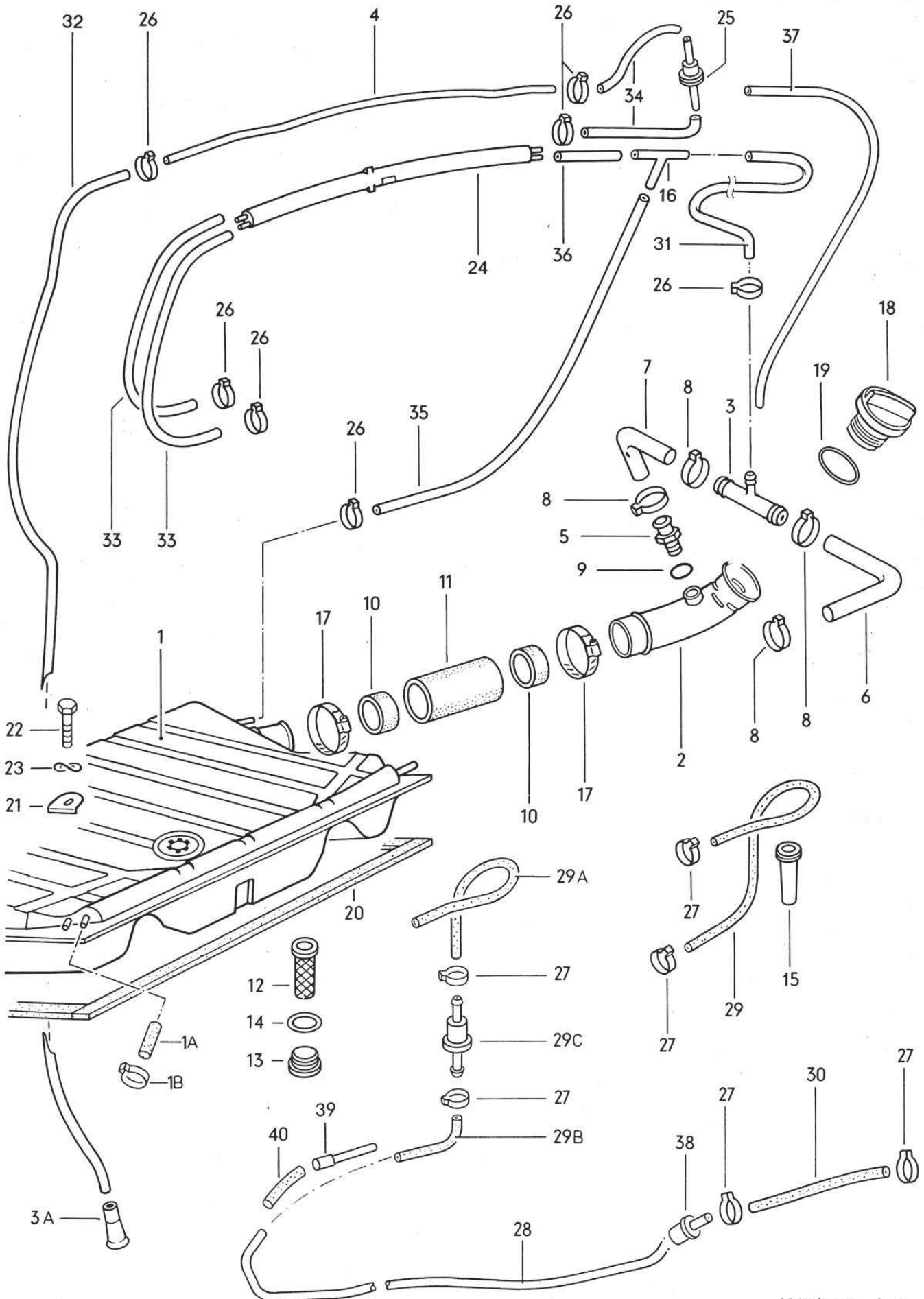

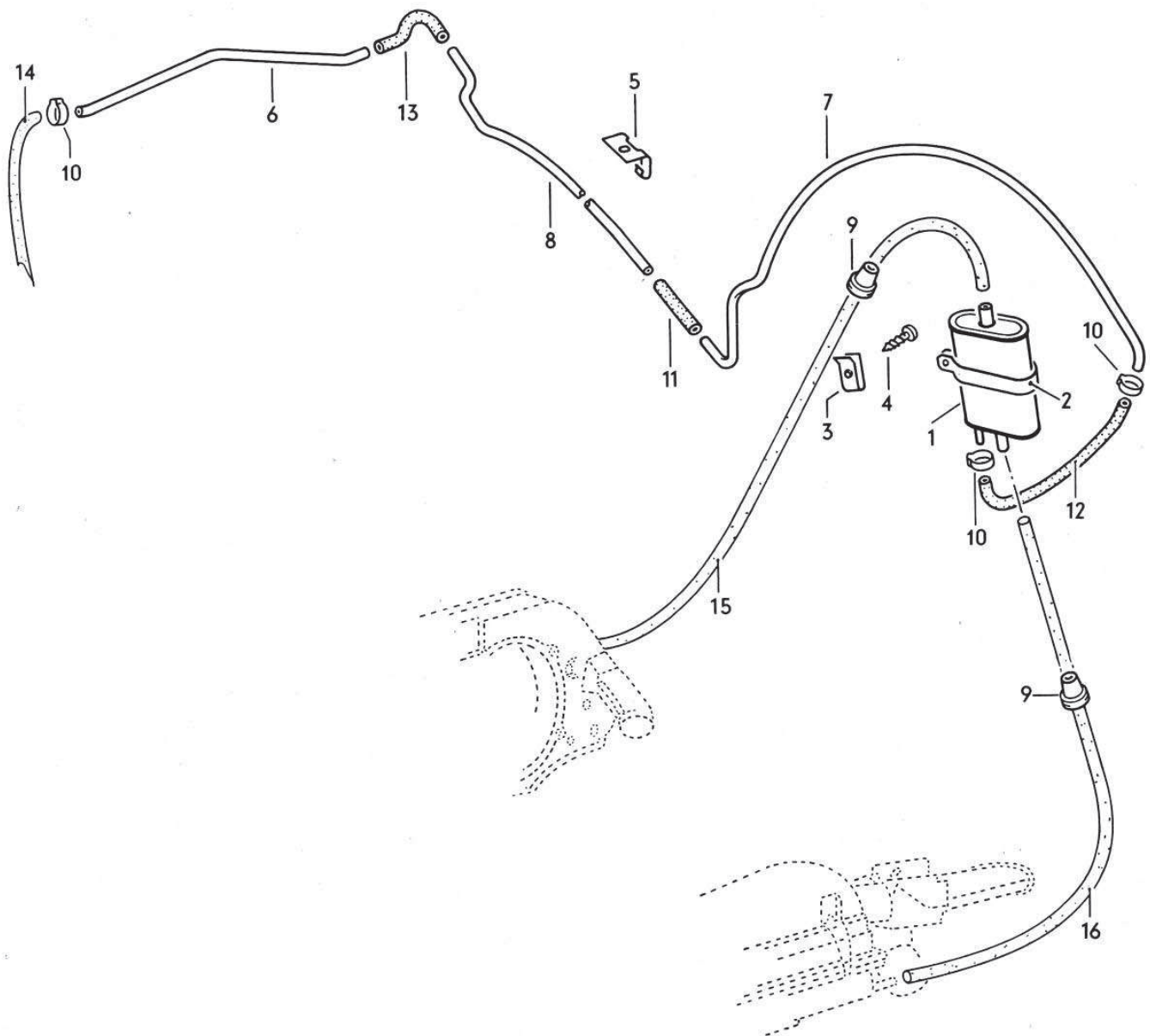

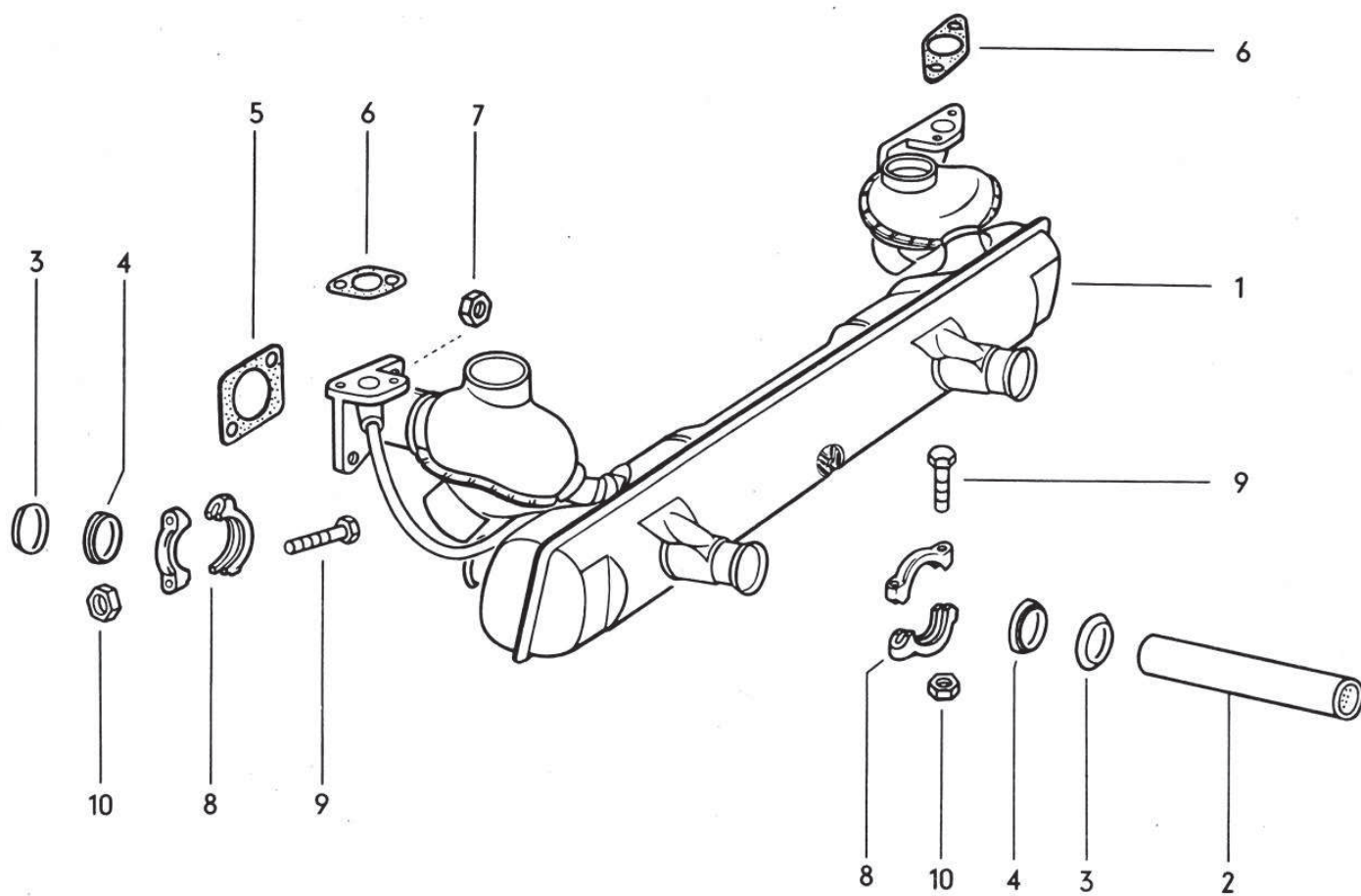

26-10

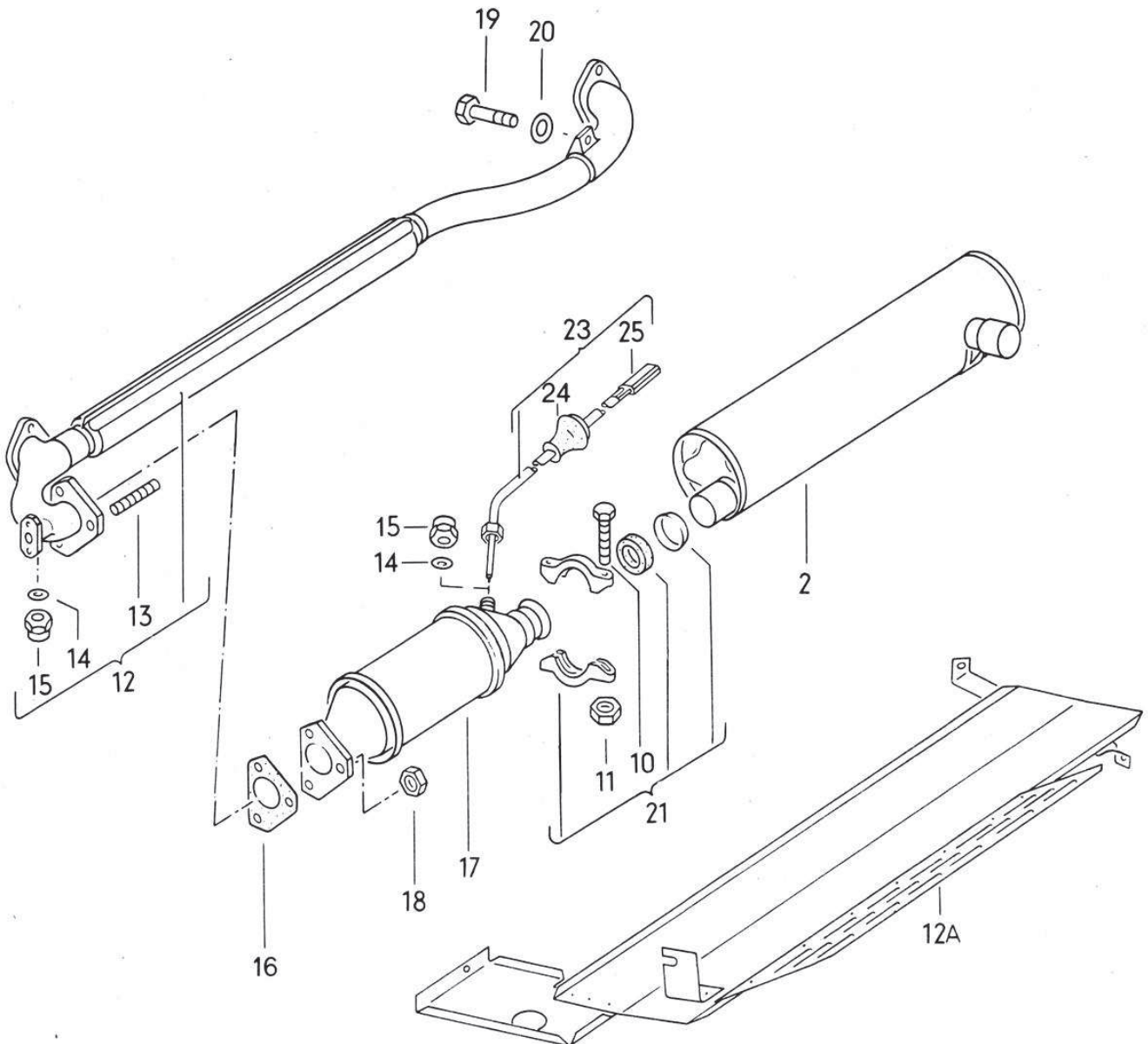
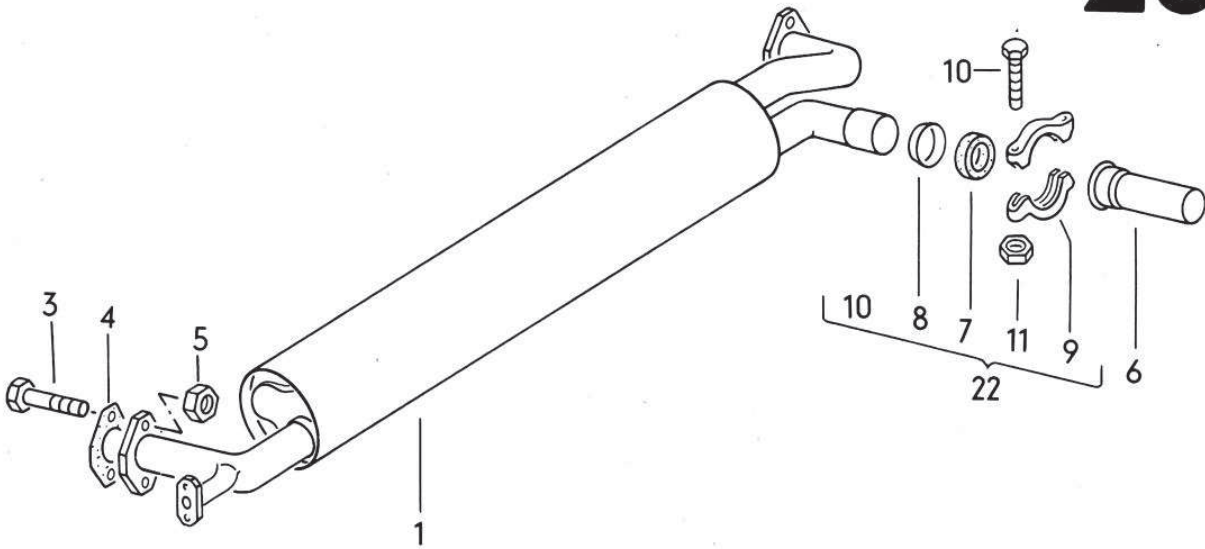

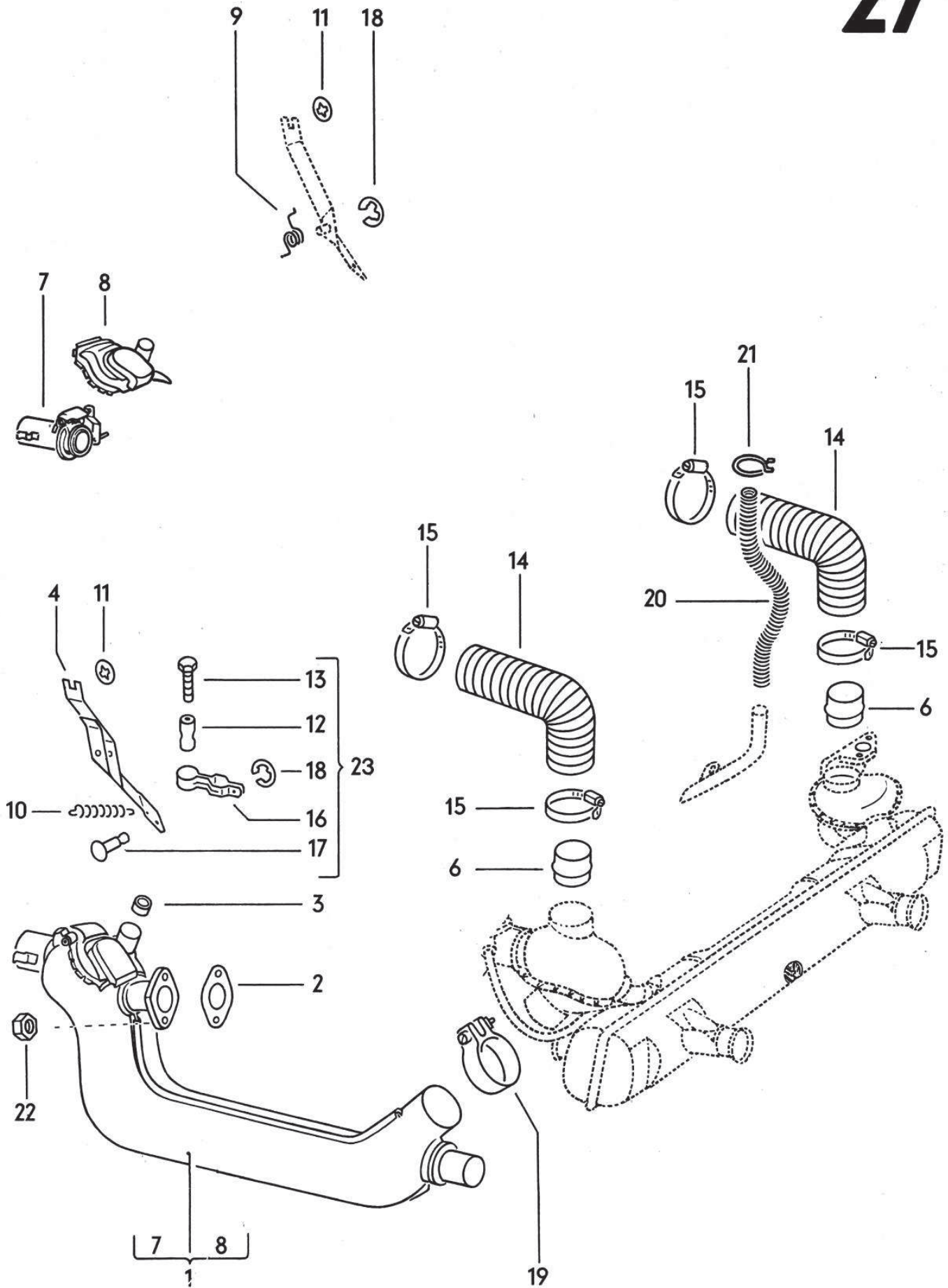

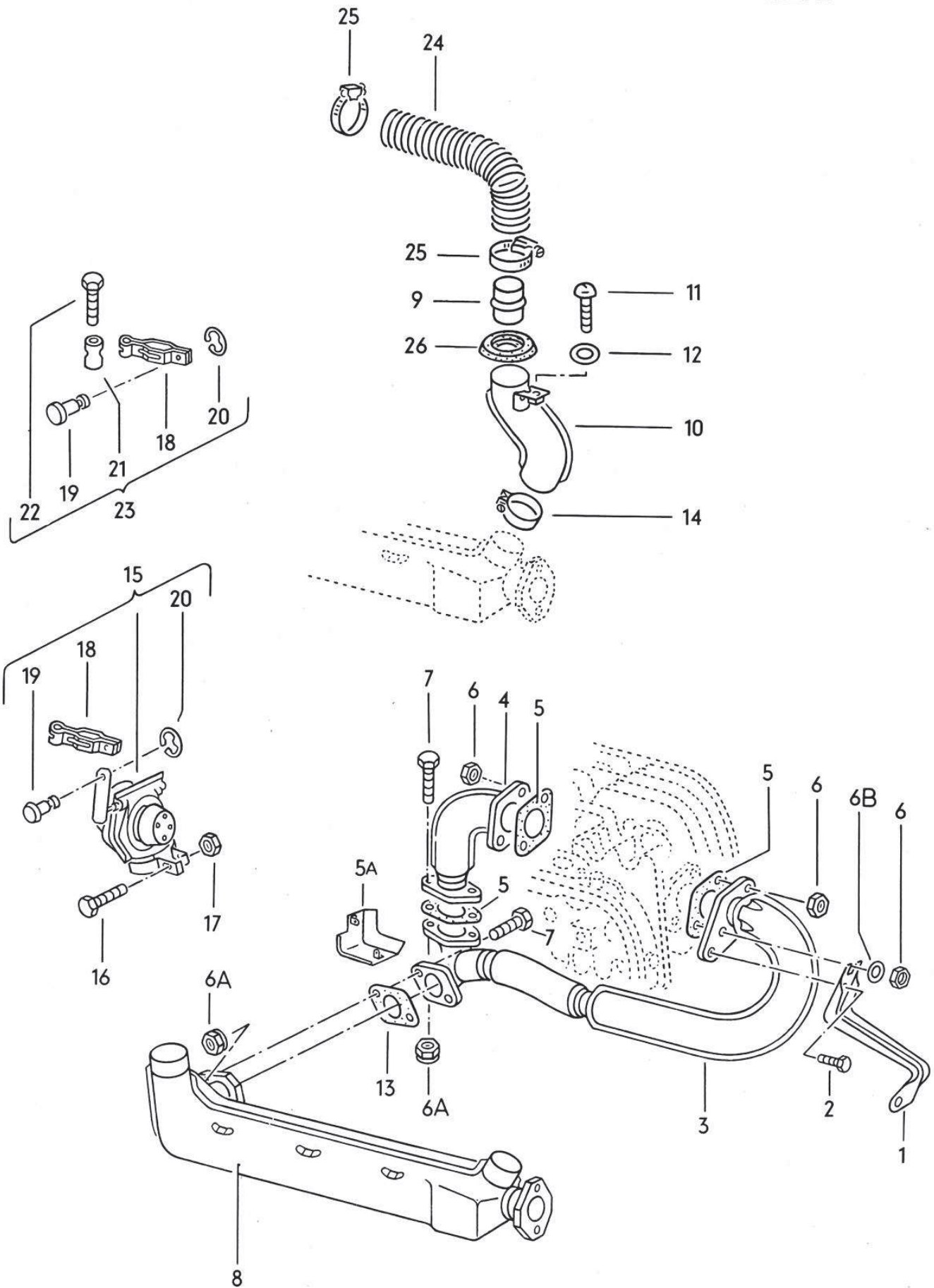

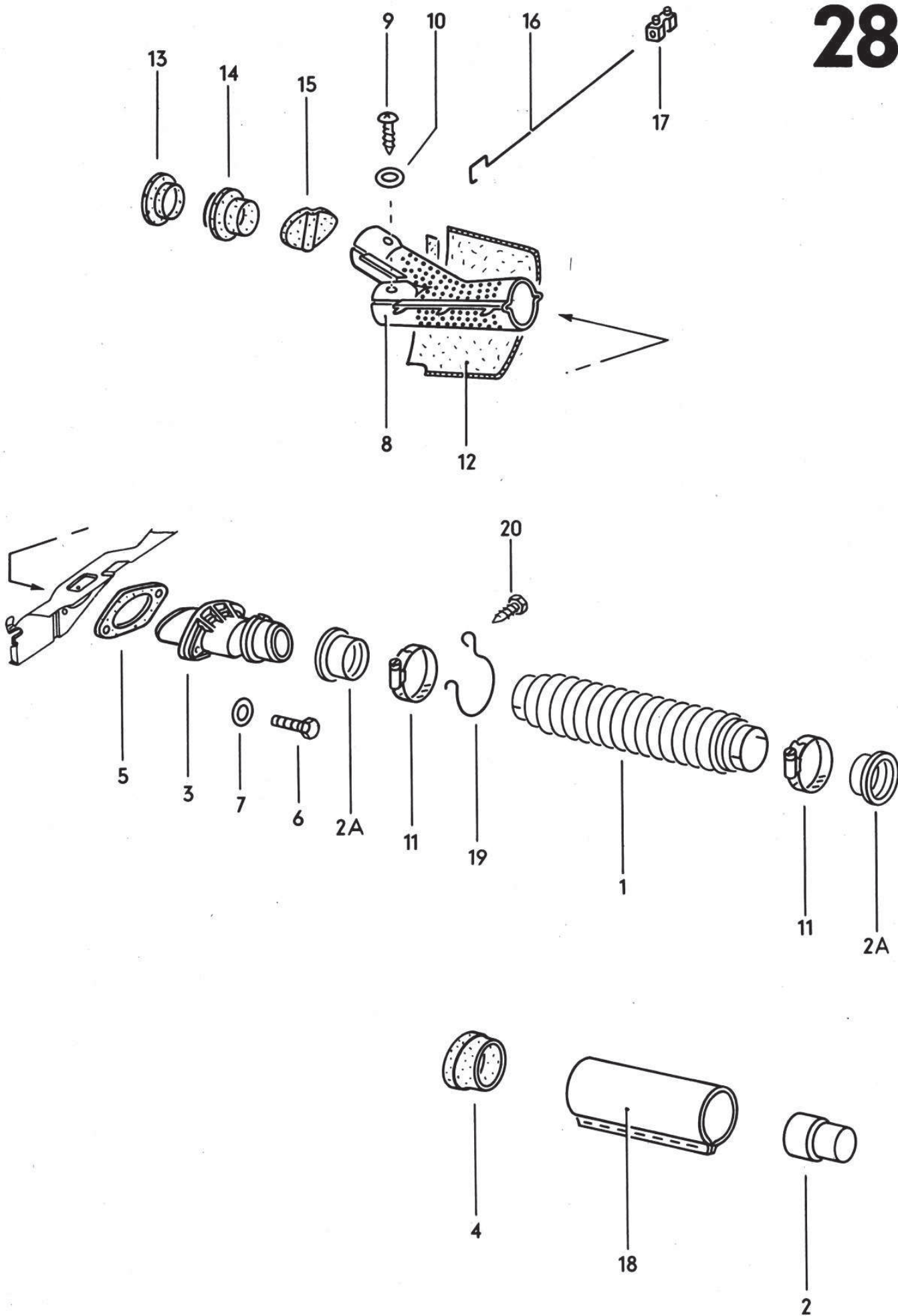

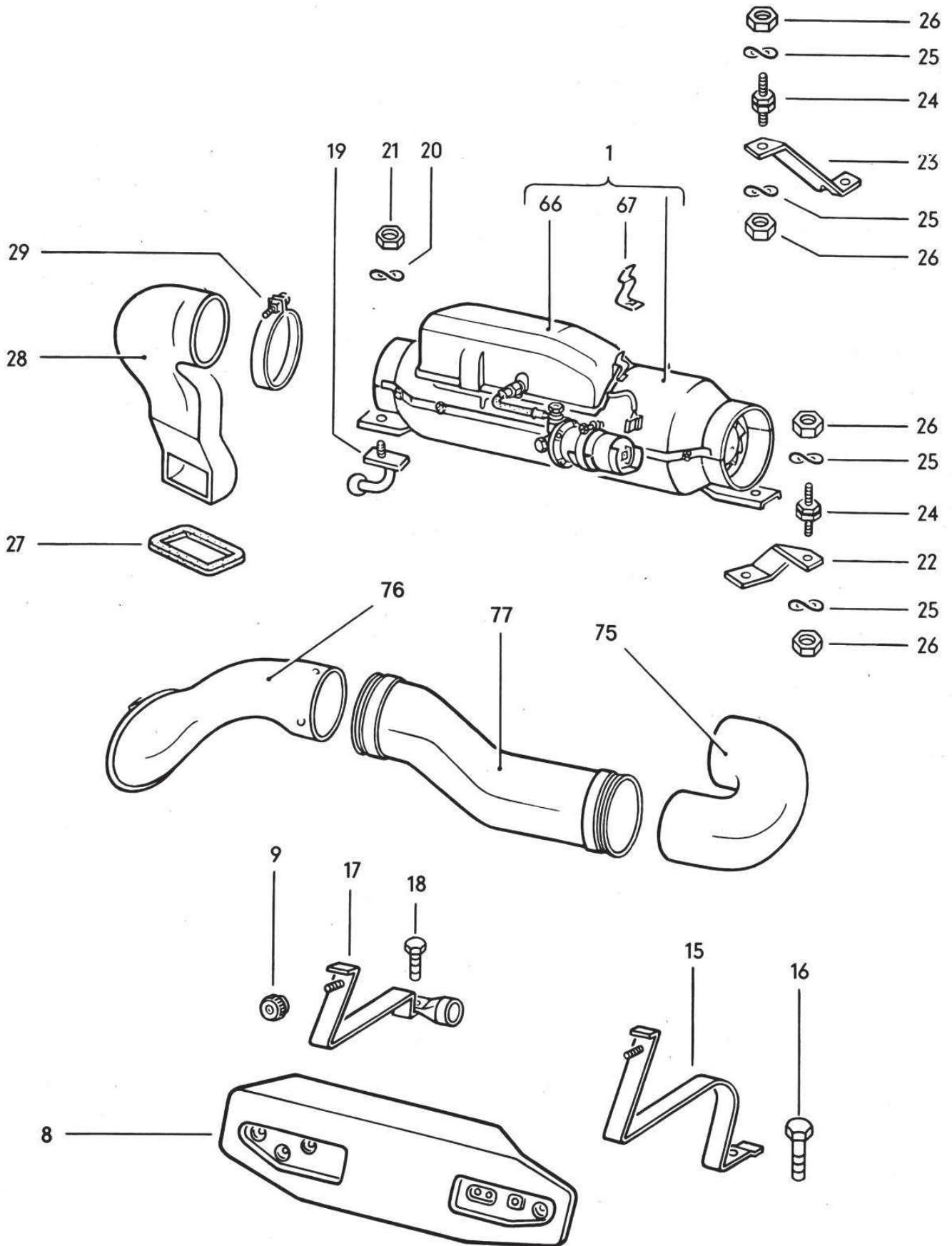

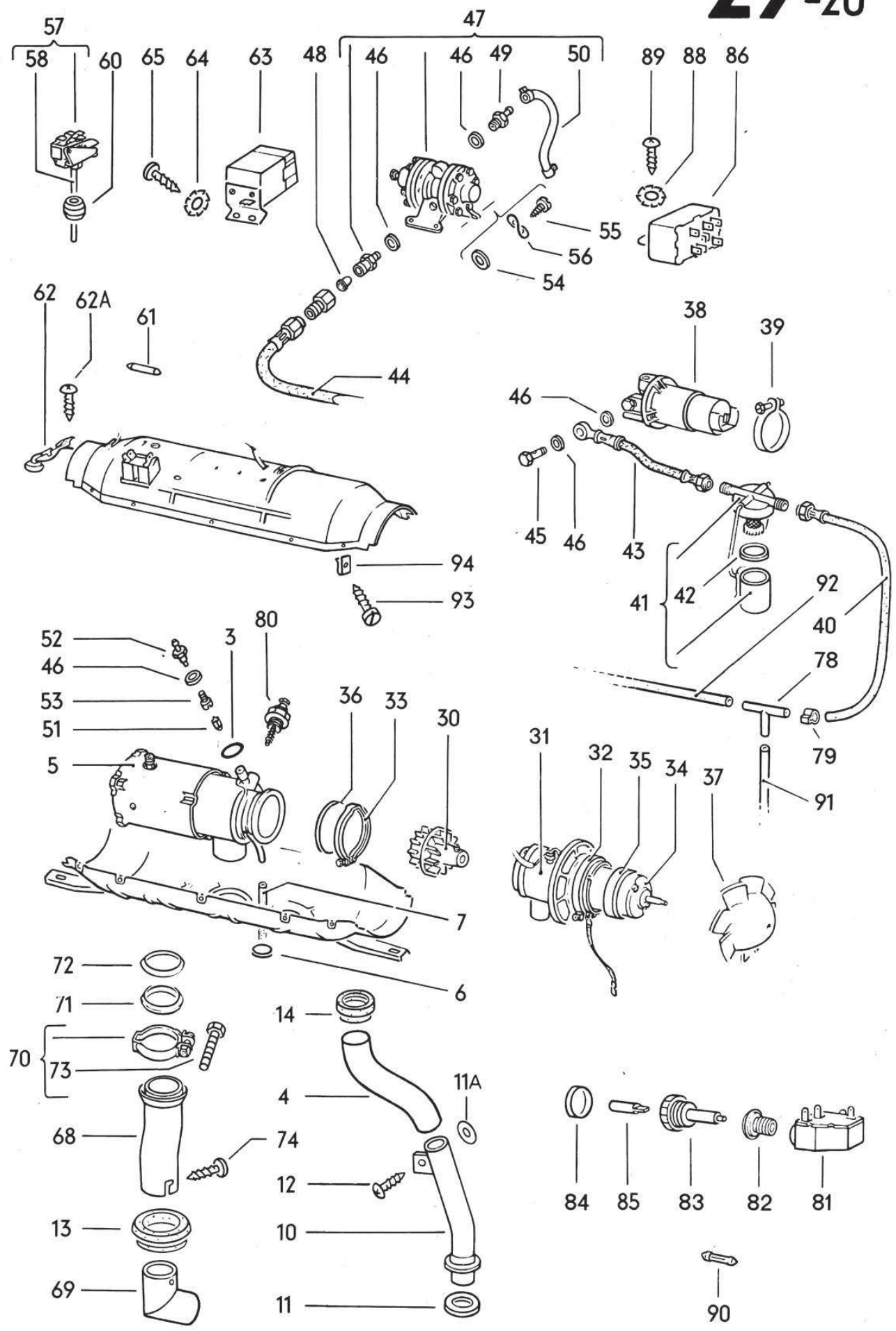

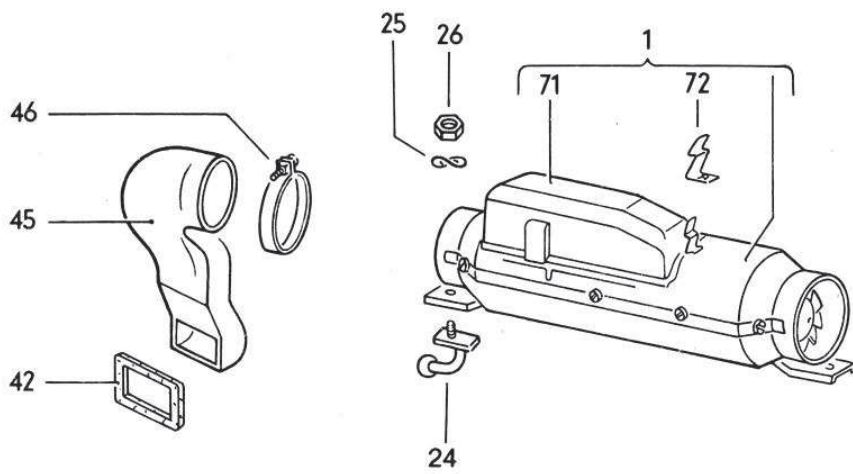
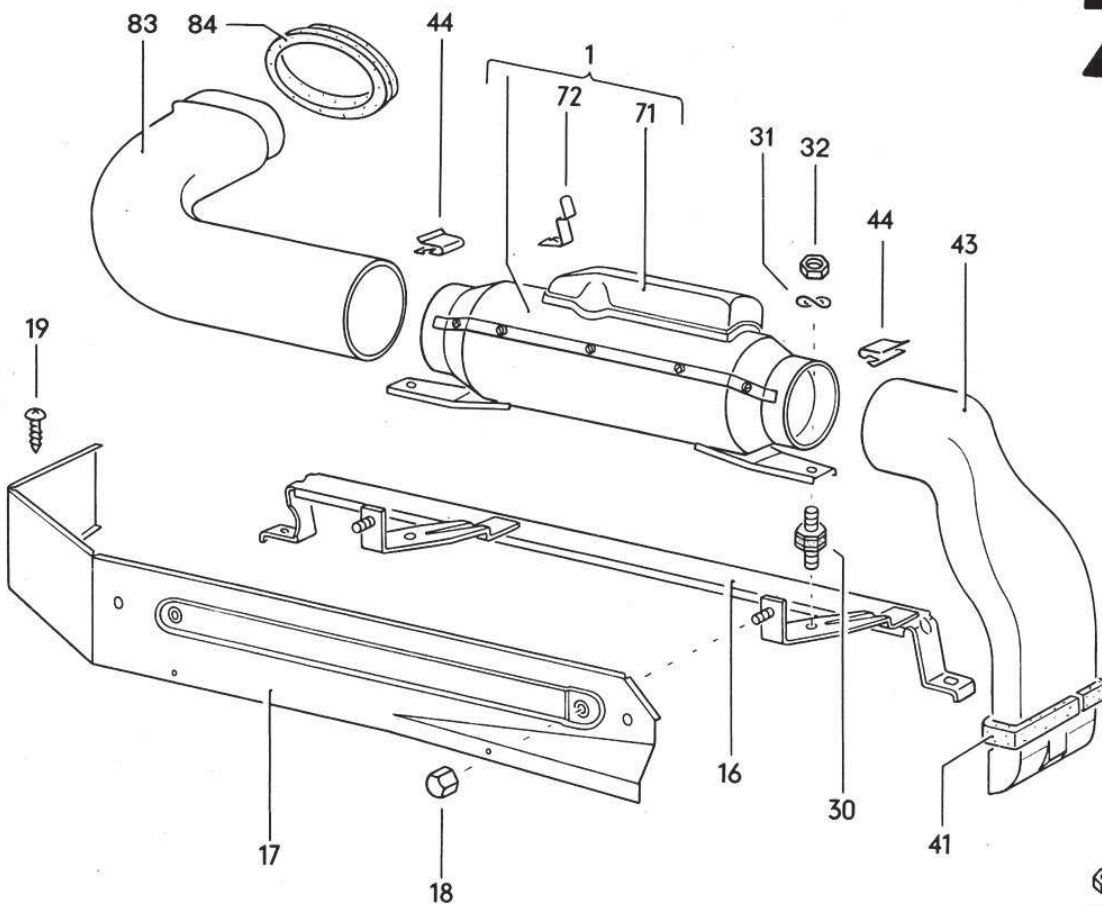

- 32
- 31
- 29
- 28
- 31
- 32
- 32
- 31
- 29
- 27
- 31
- 32

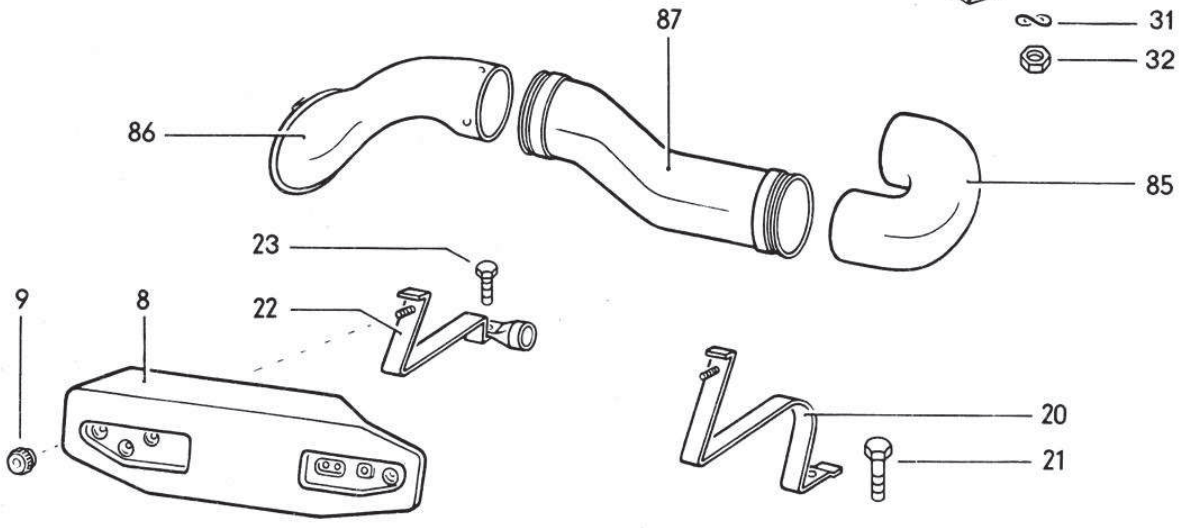

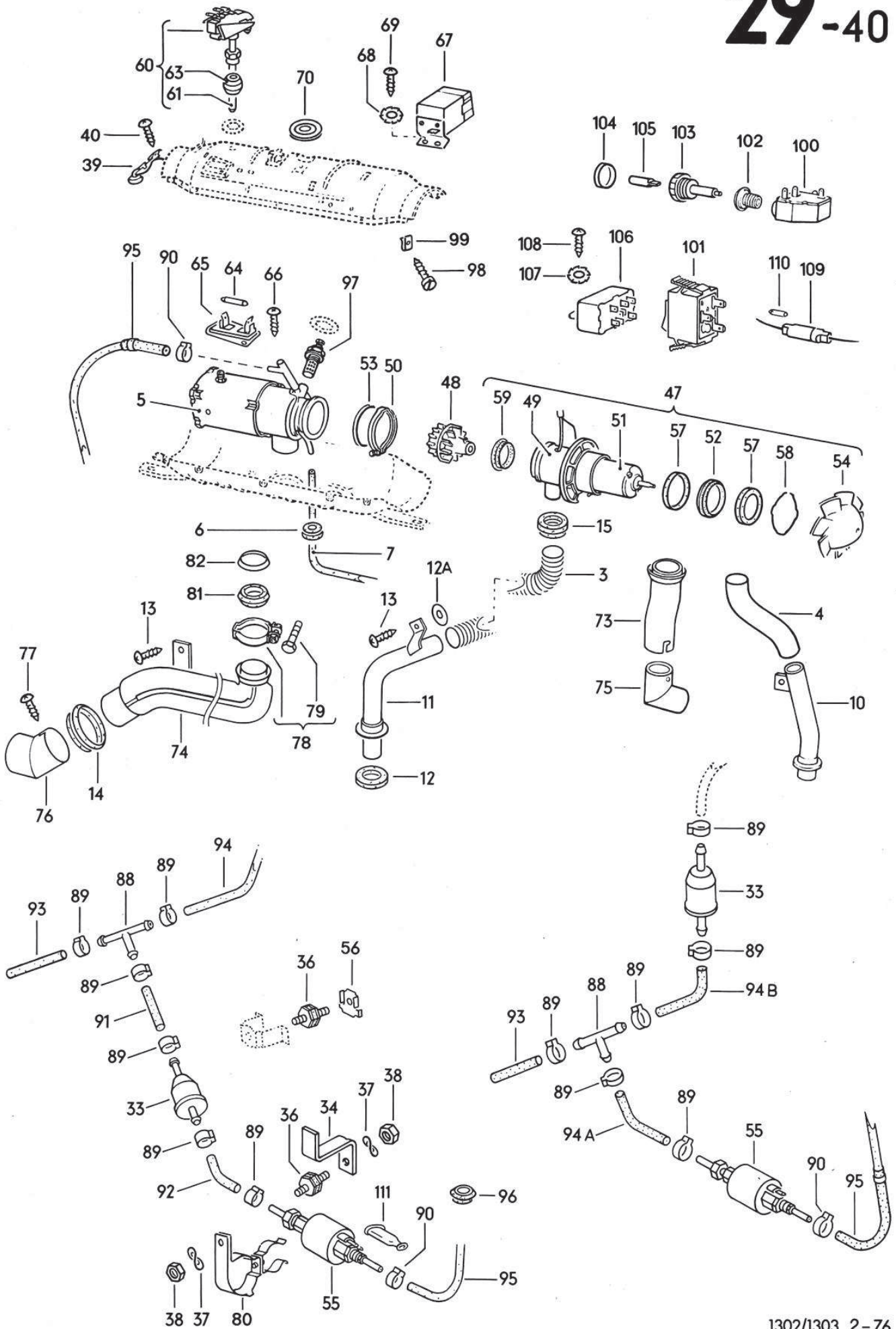

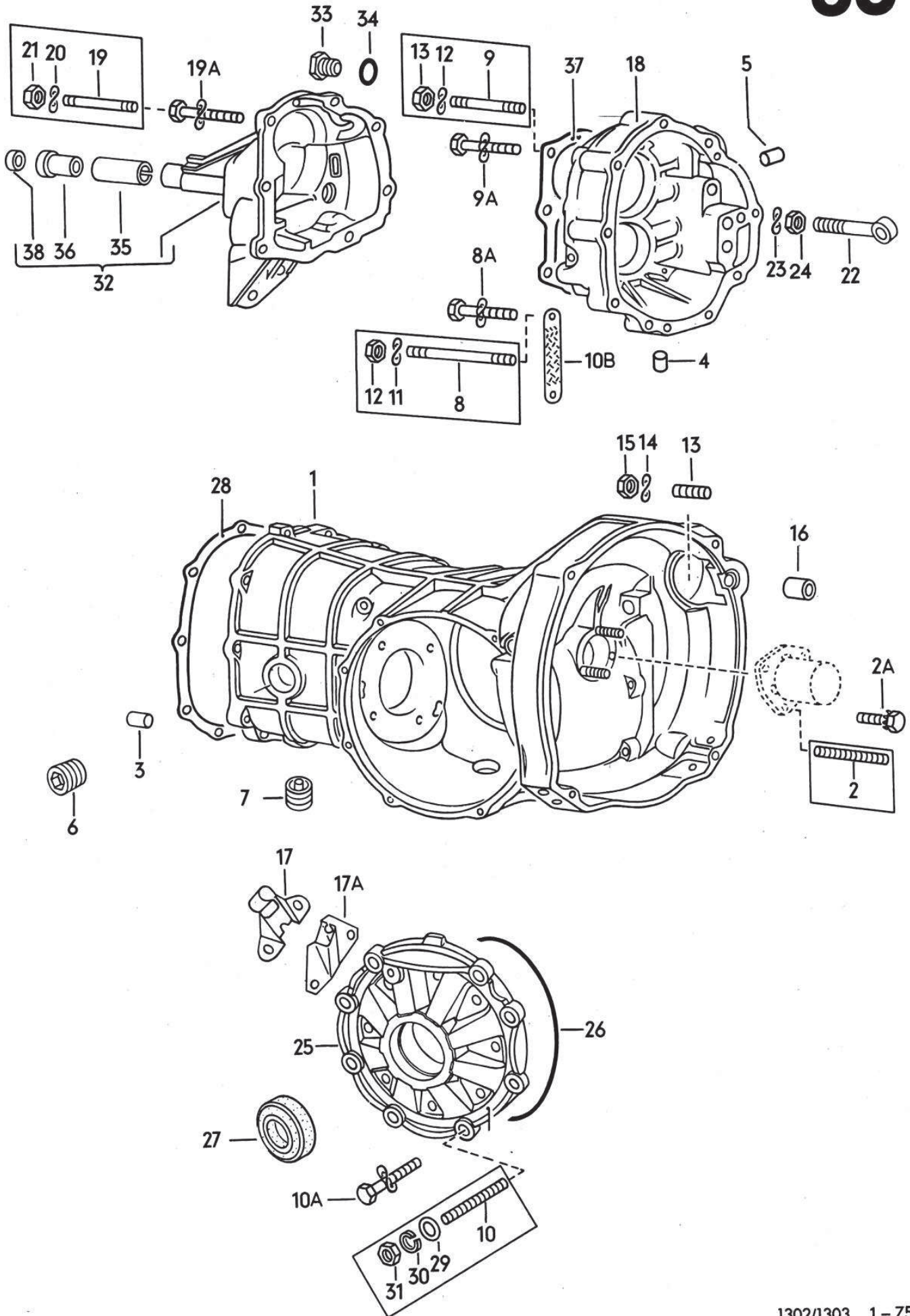

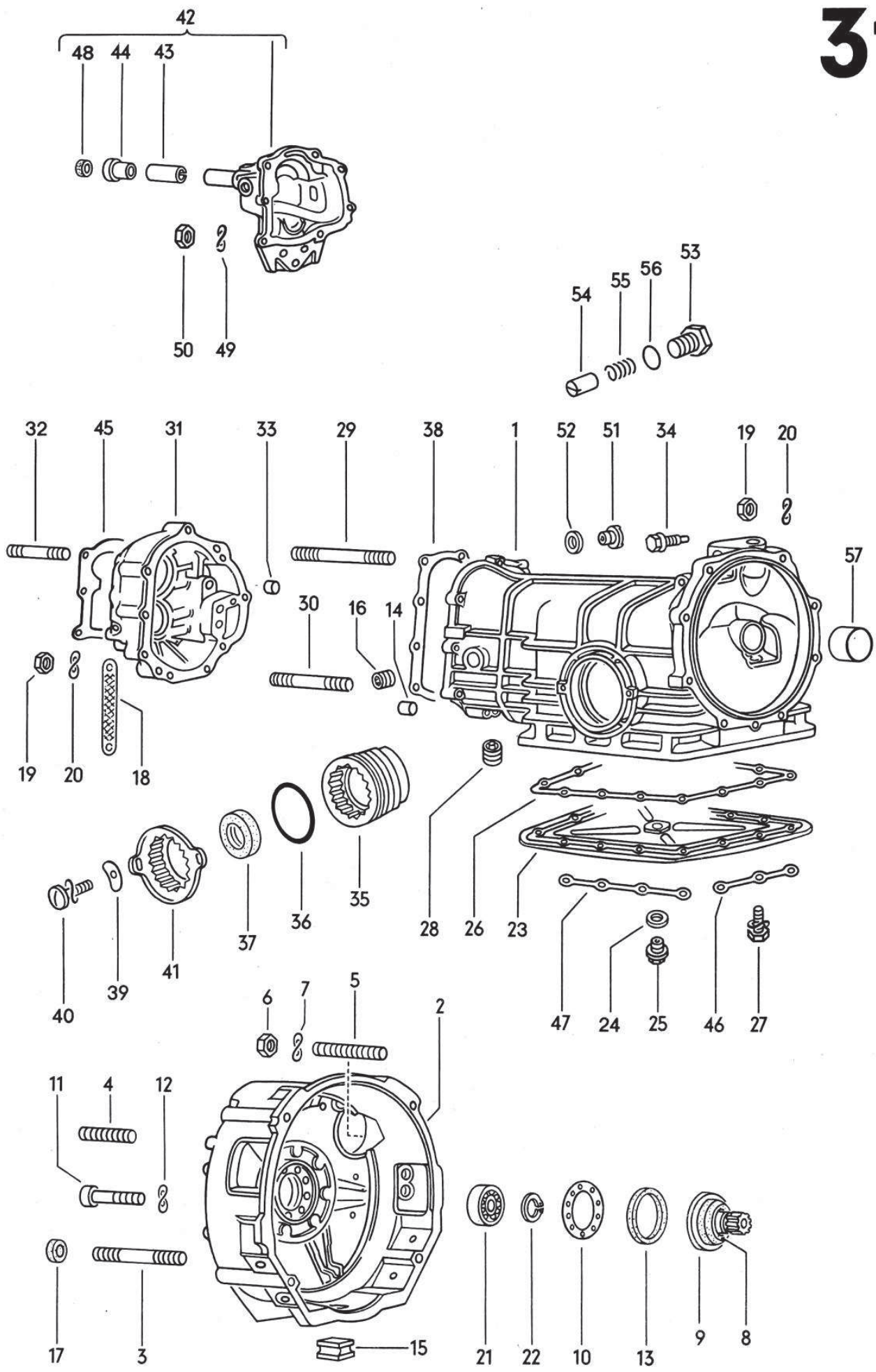

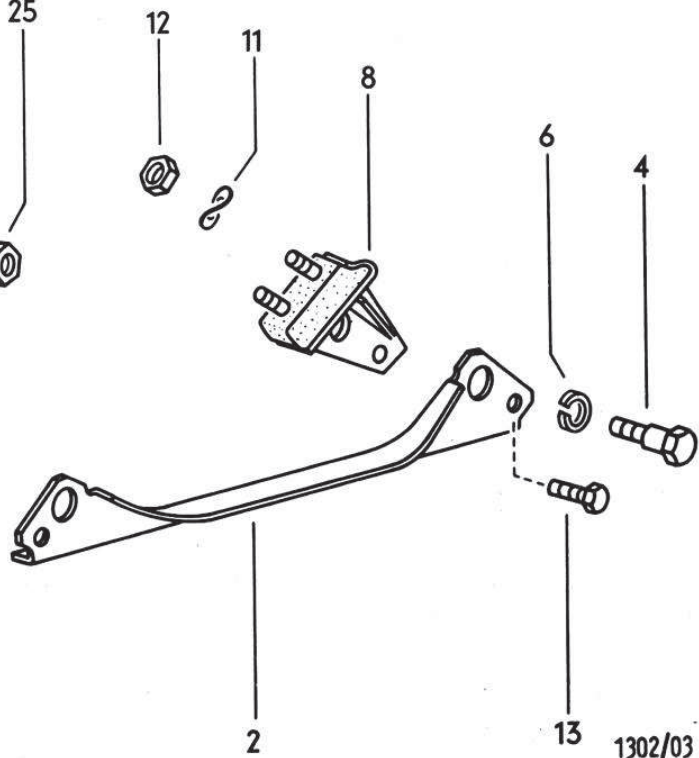
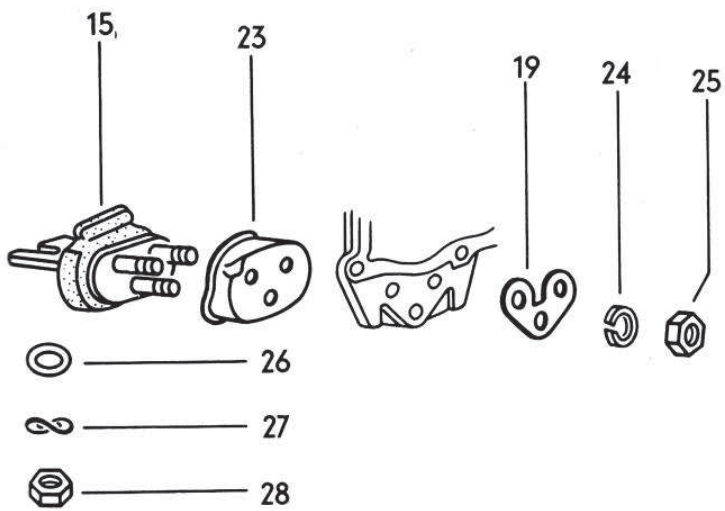
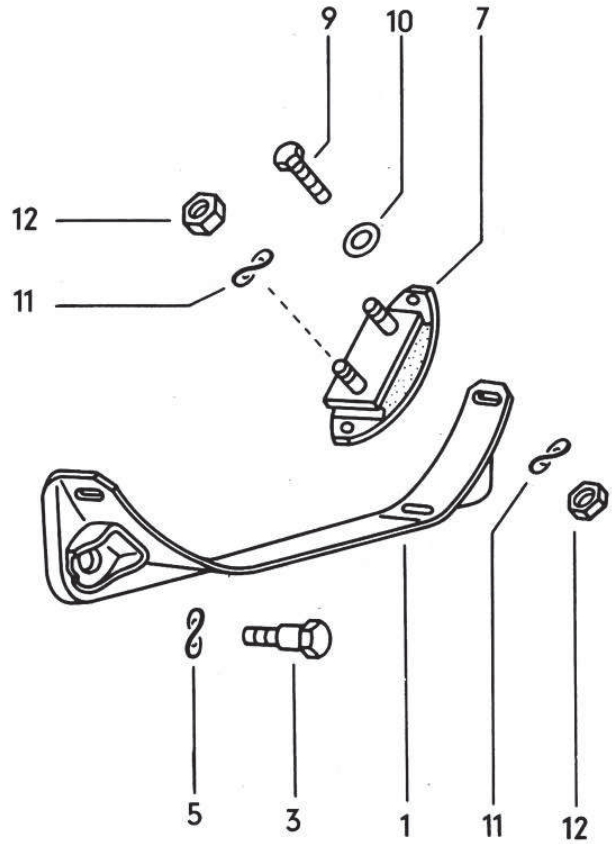
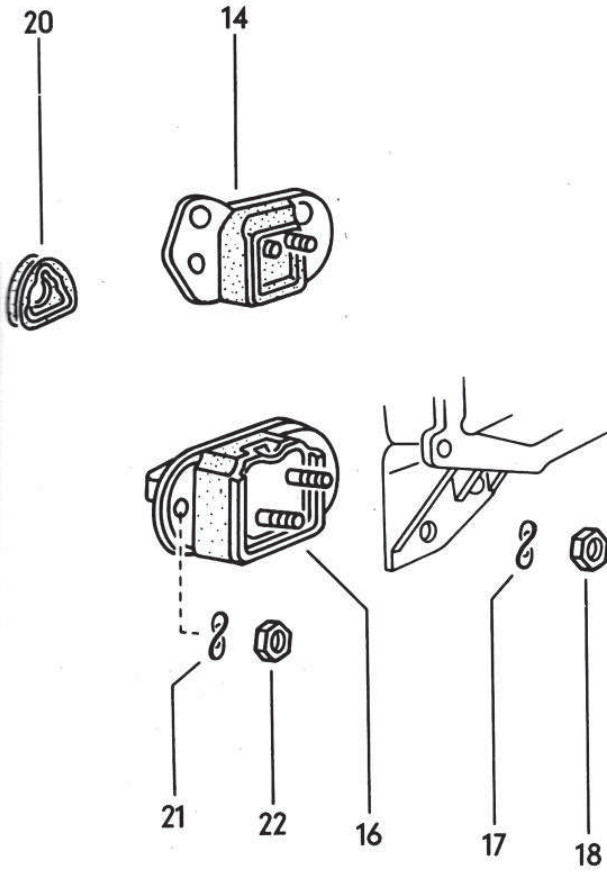

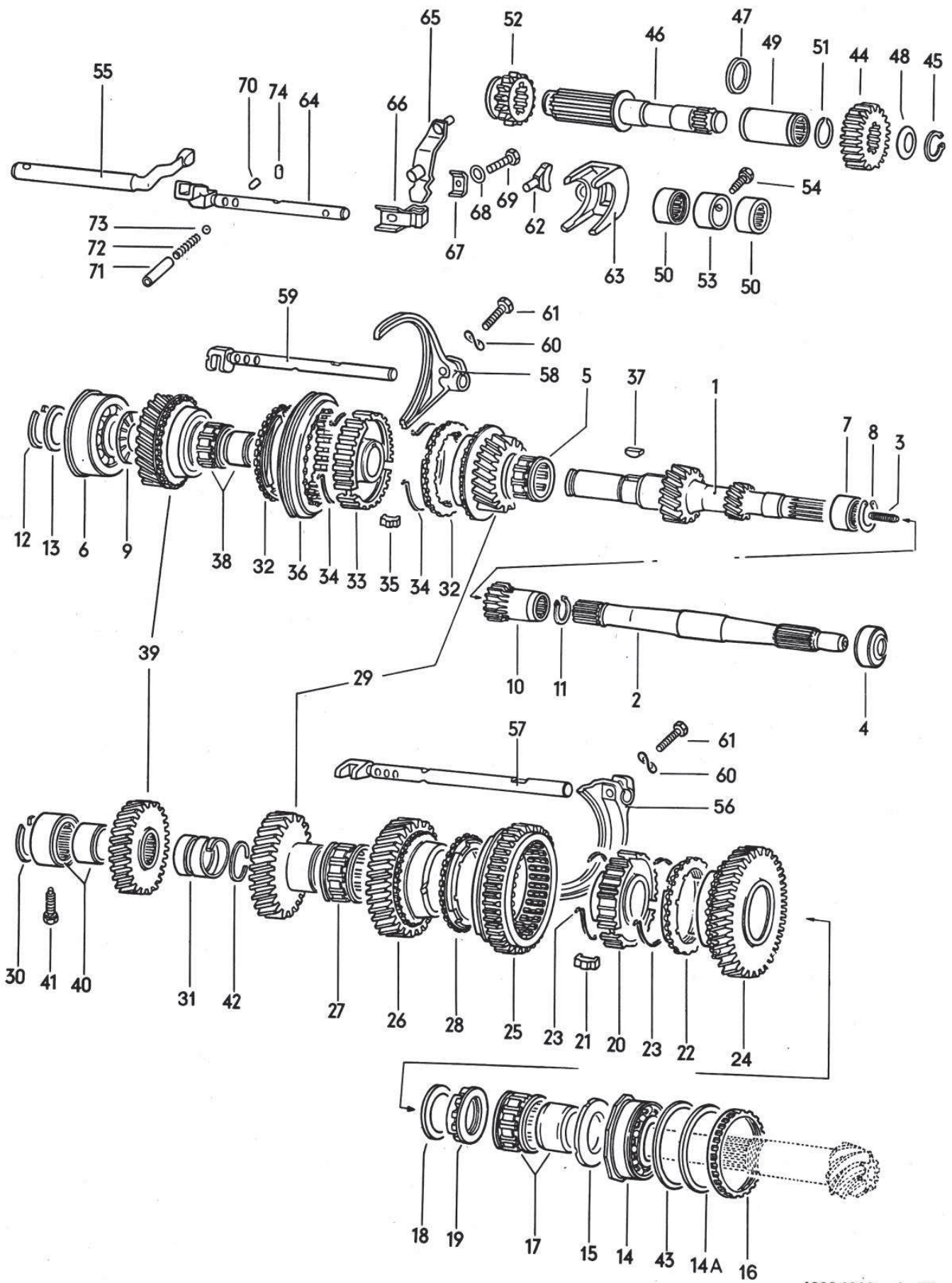

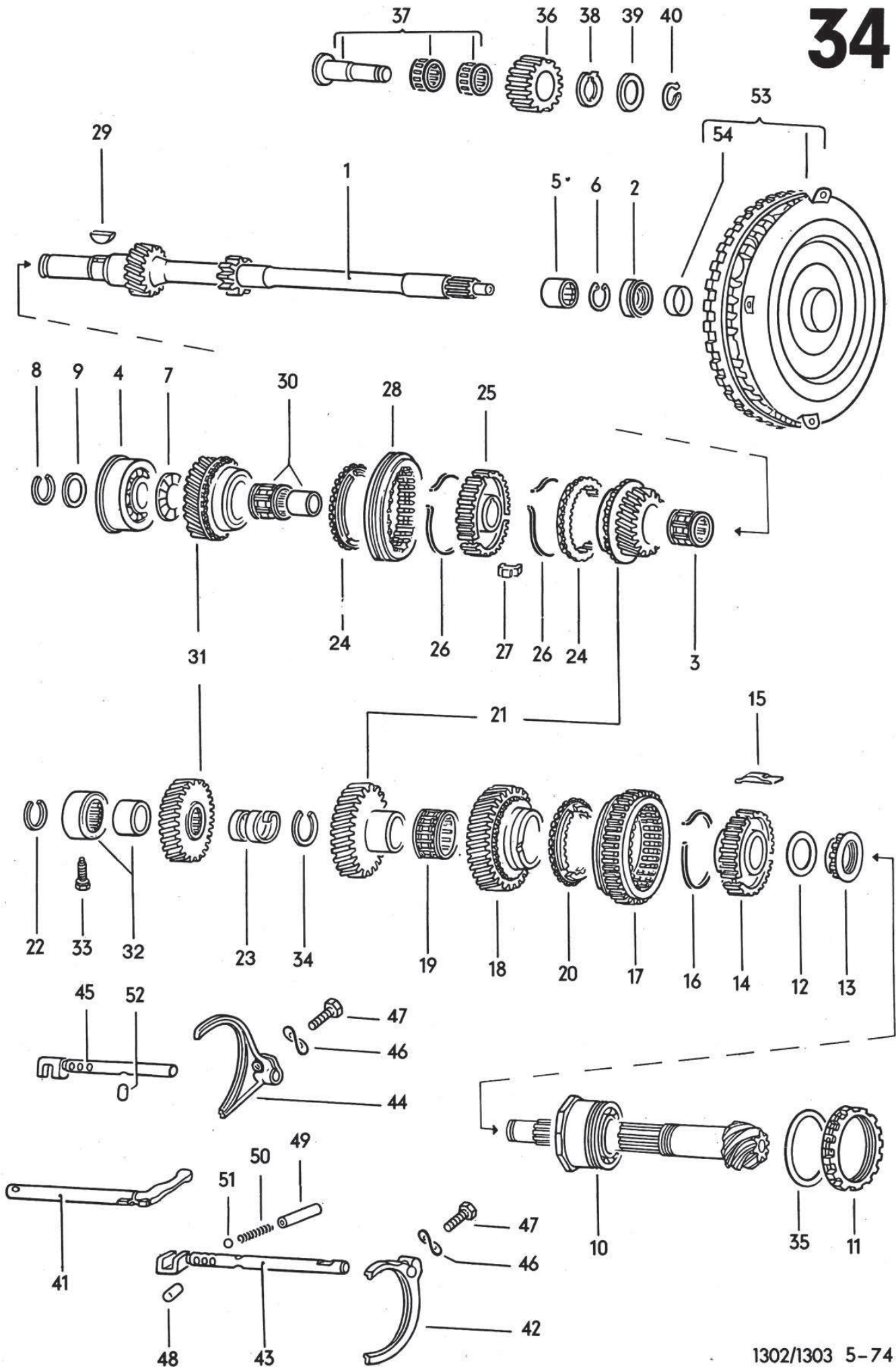

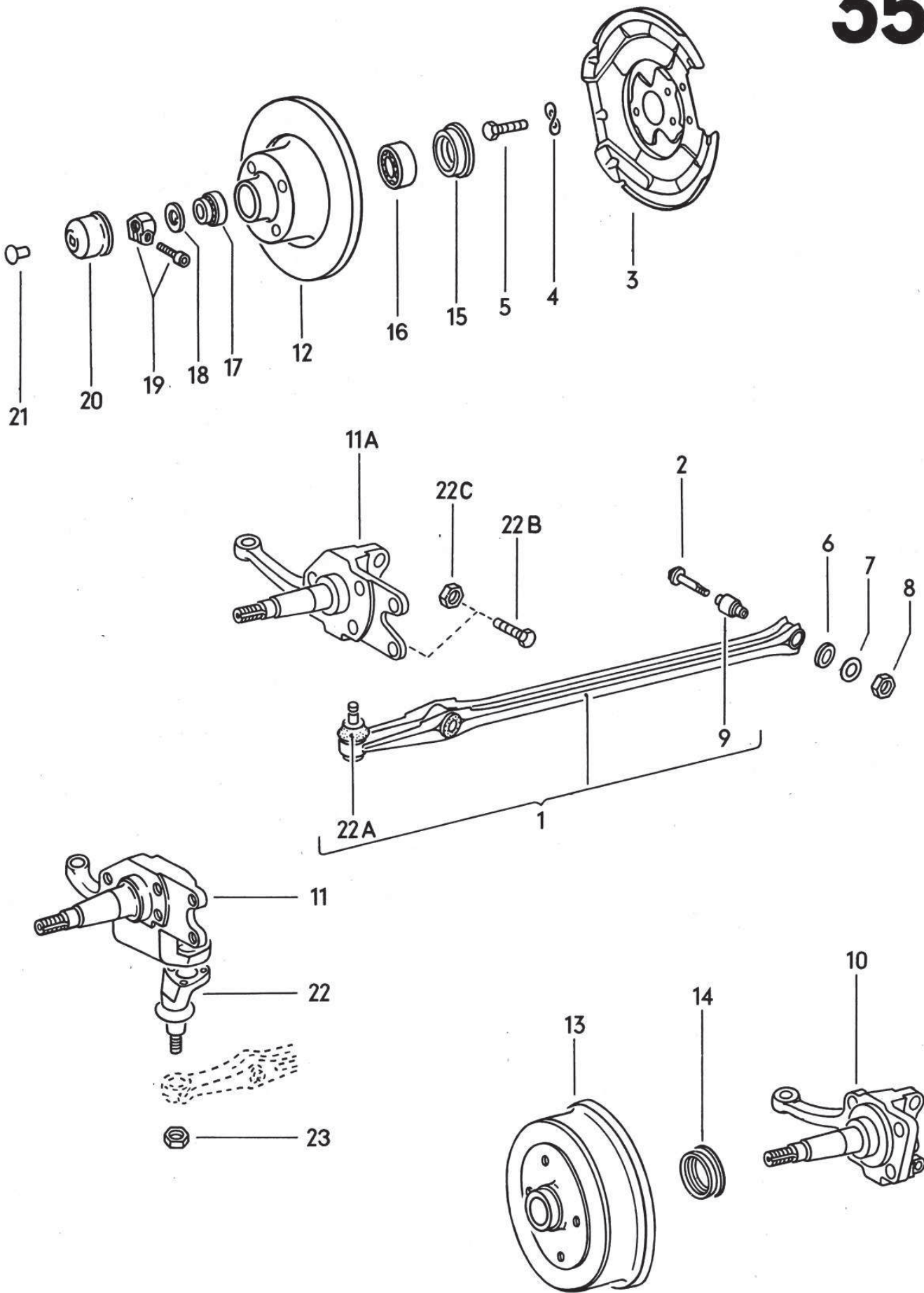

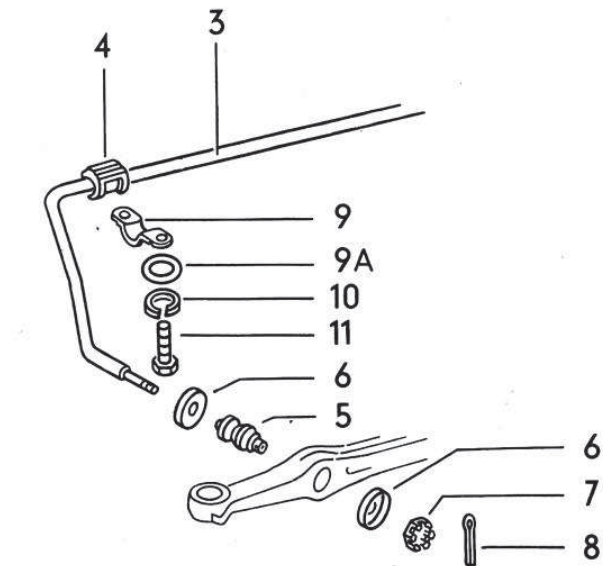
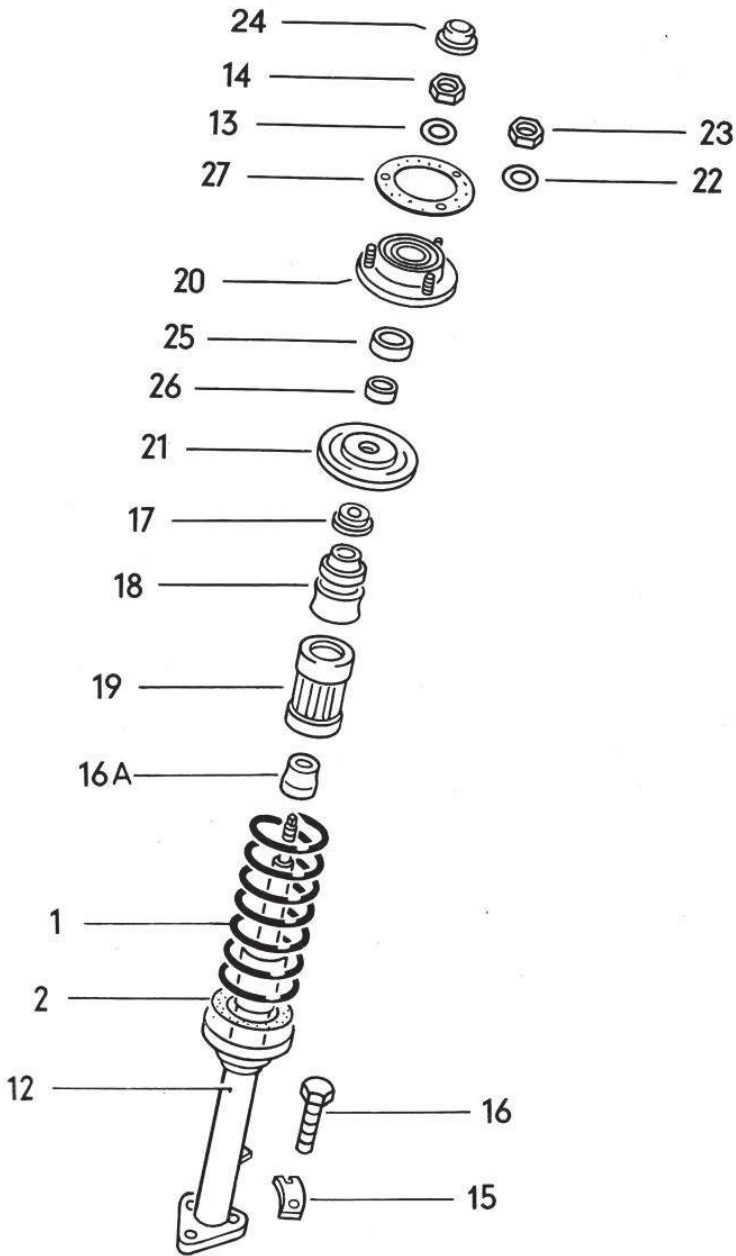

37

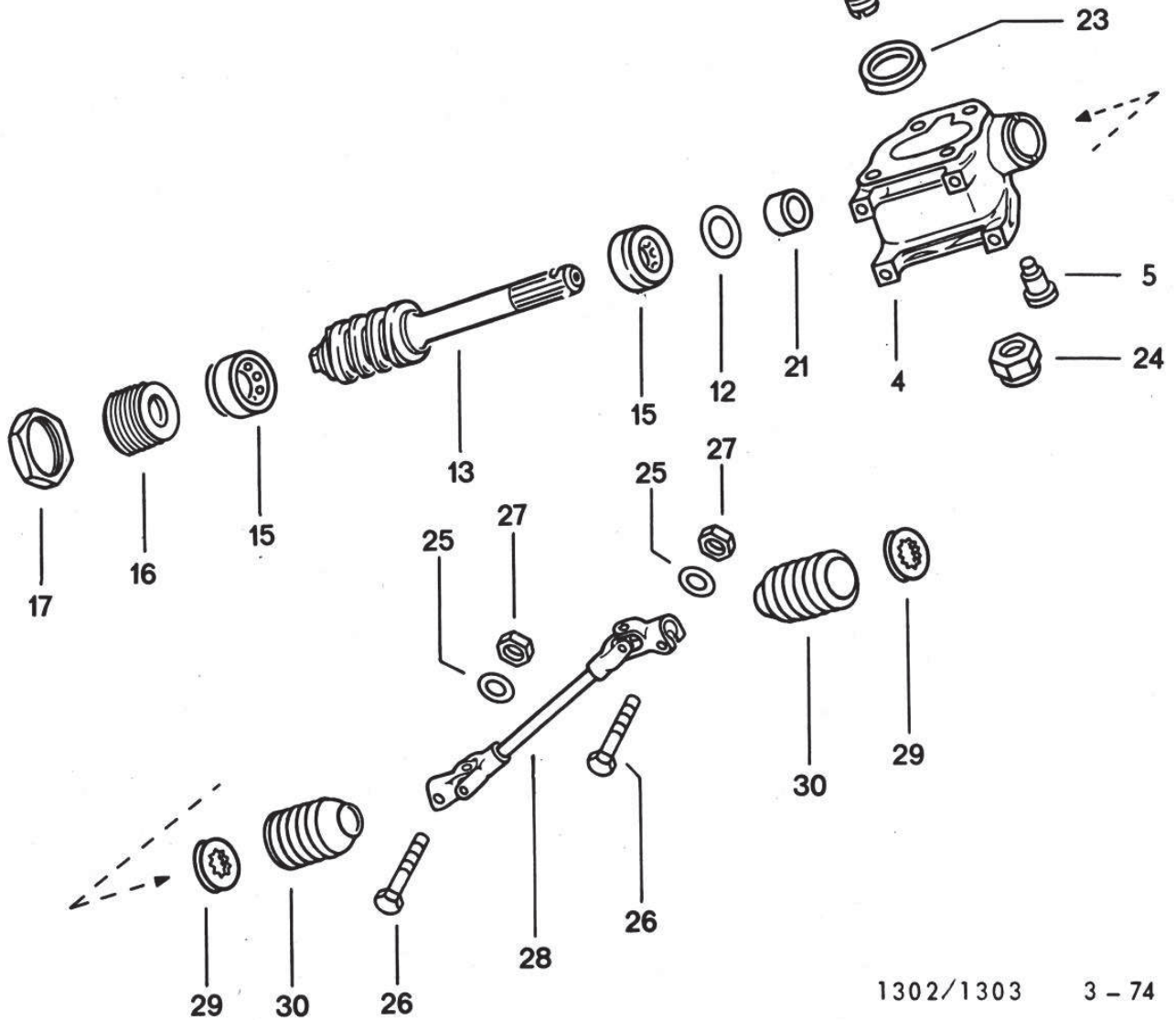
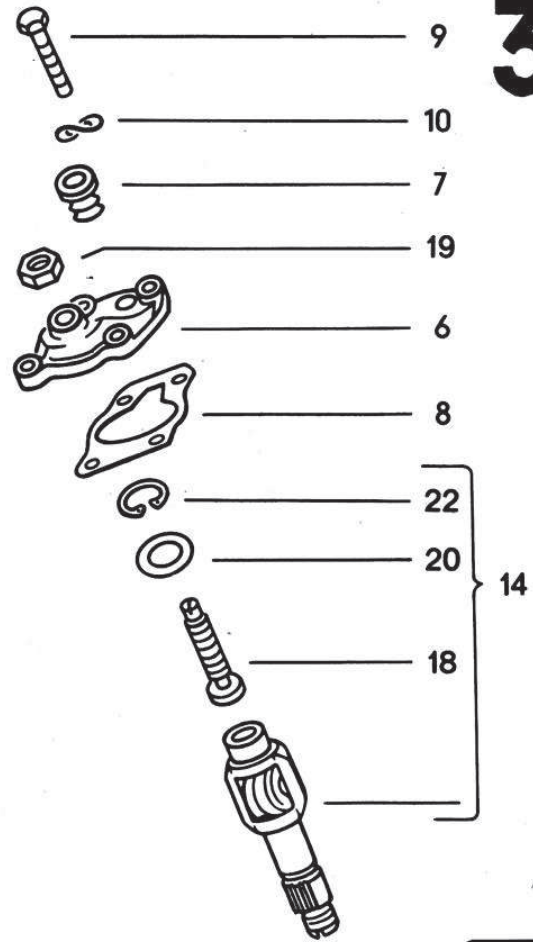
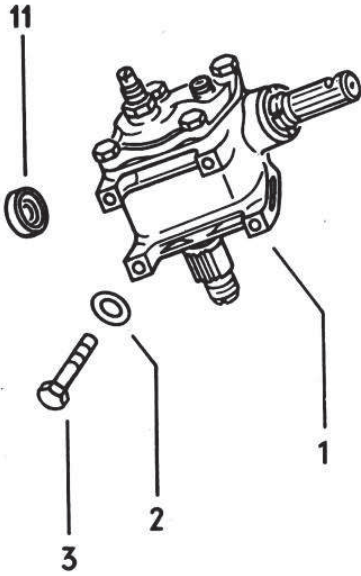

37-10

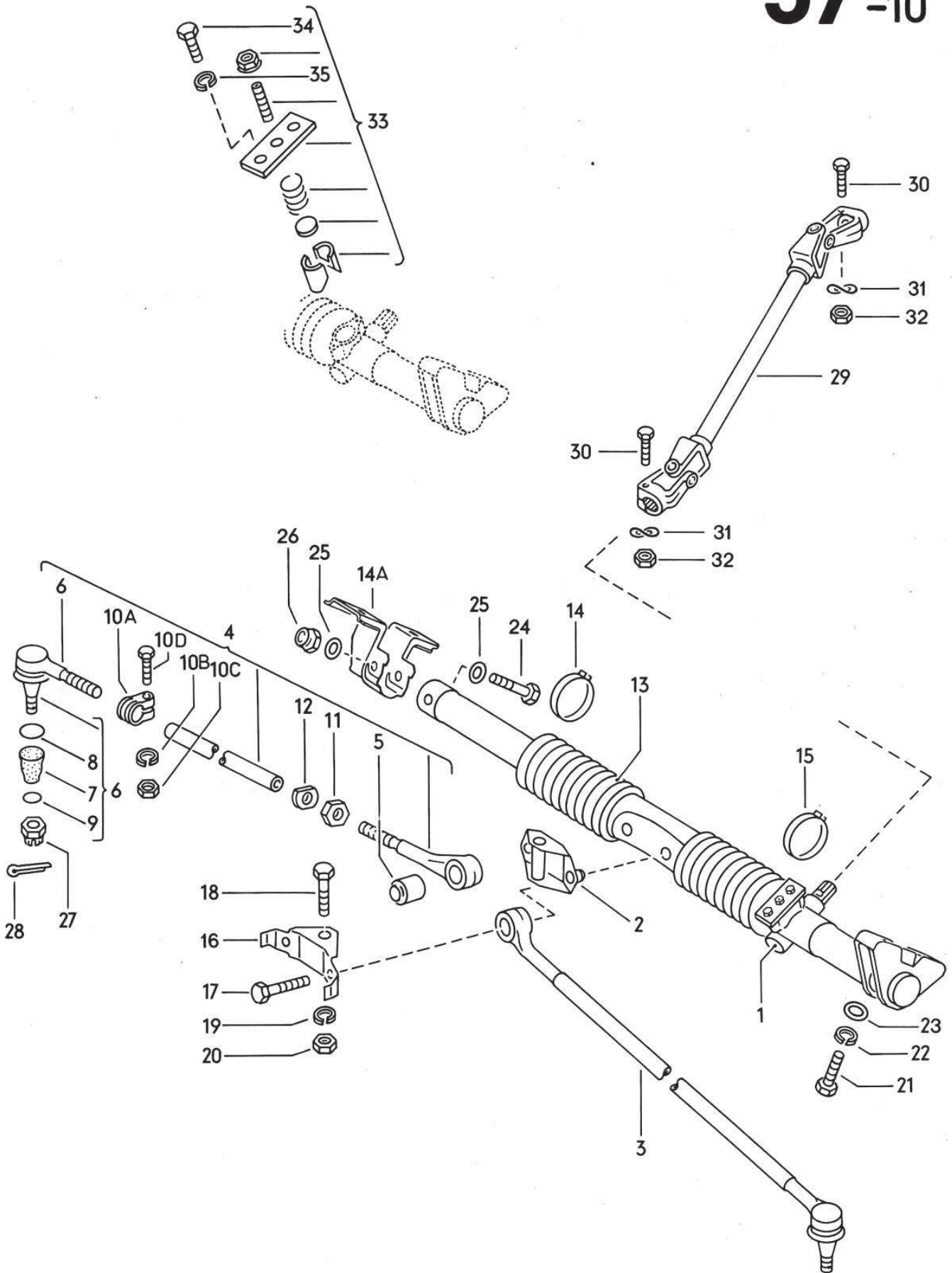

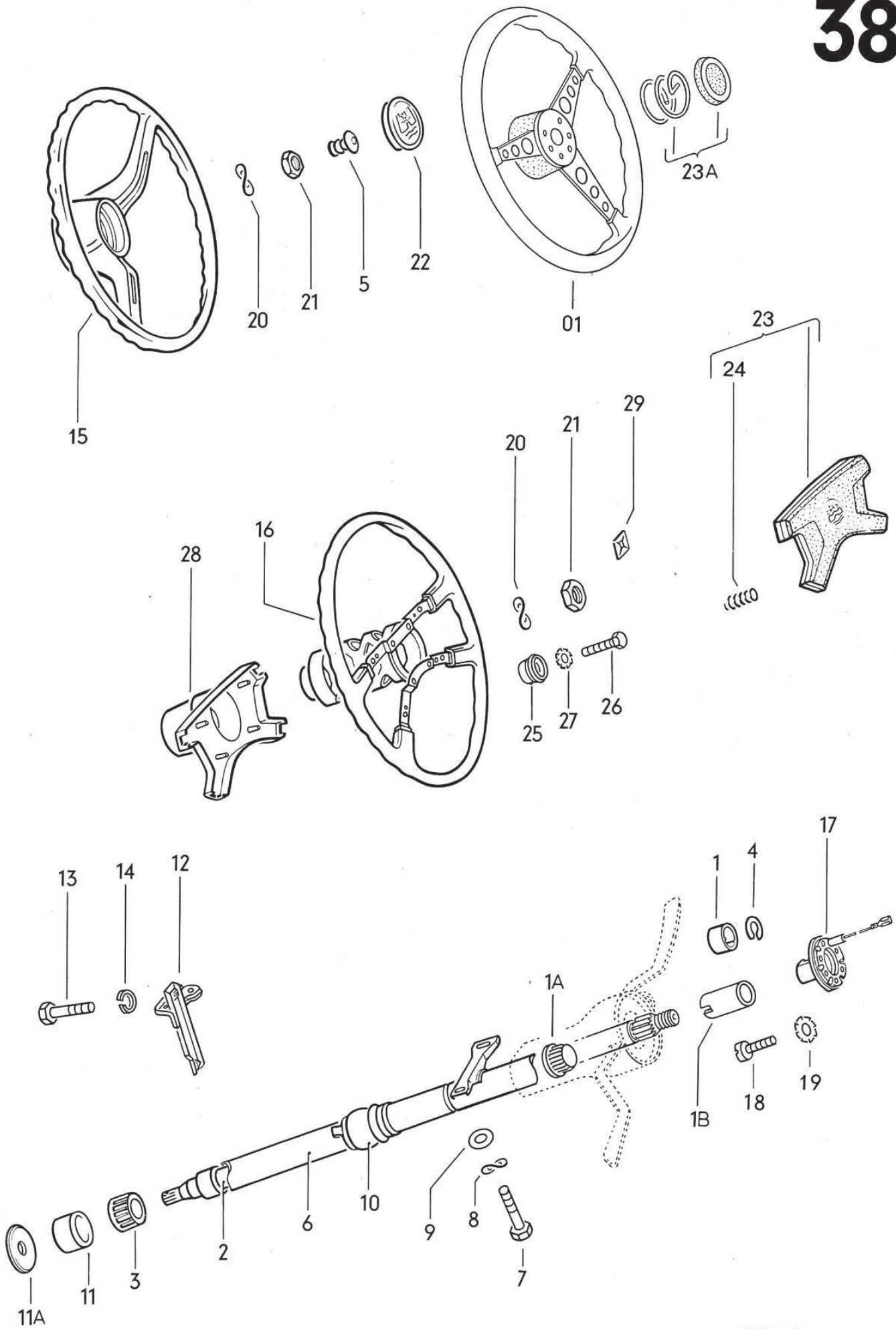

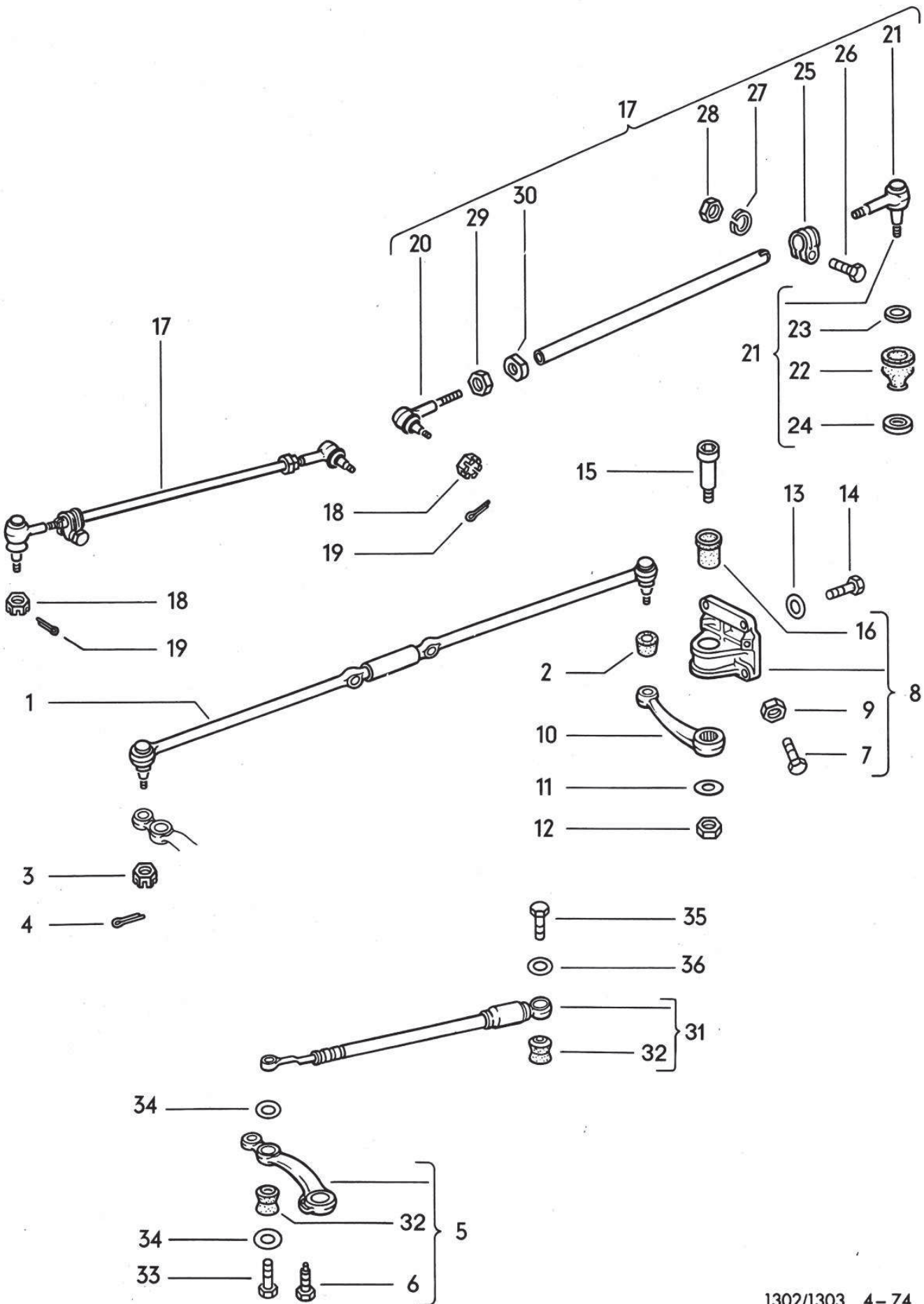

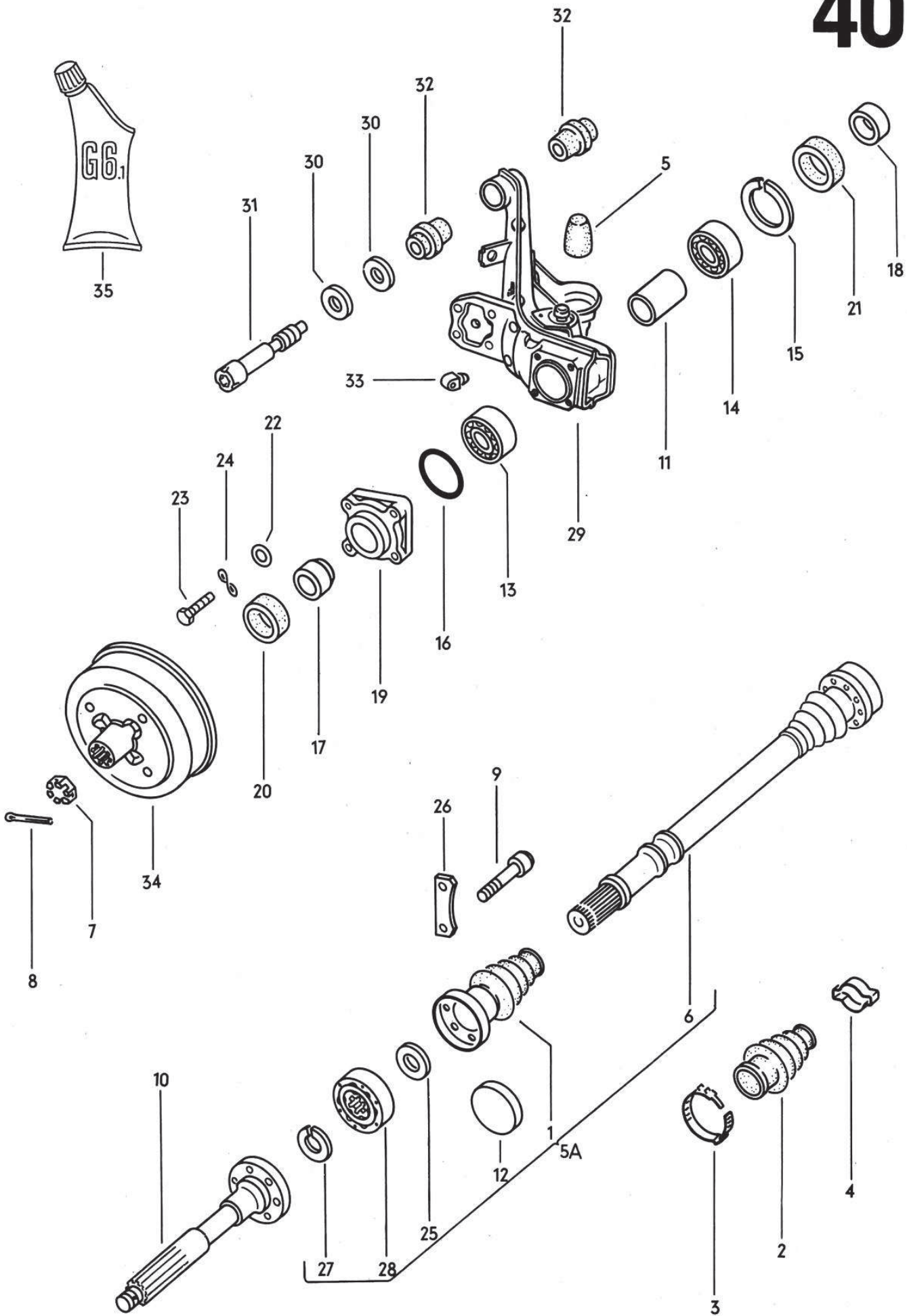

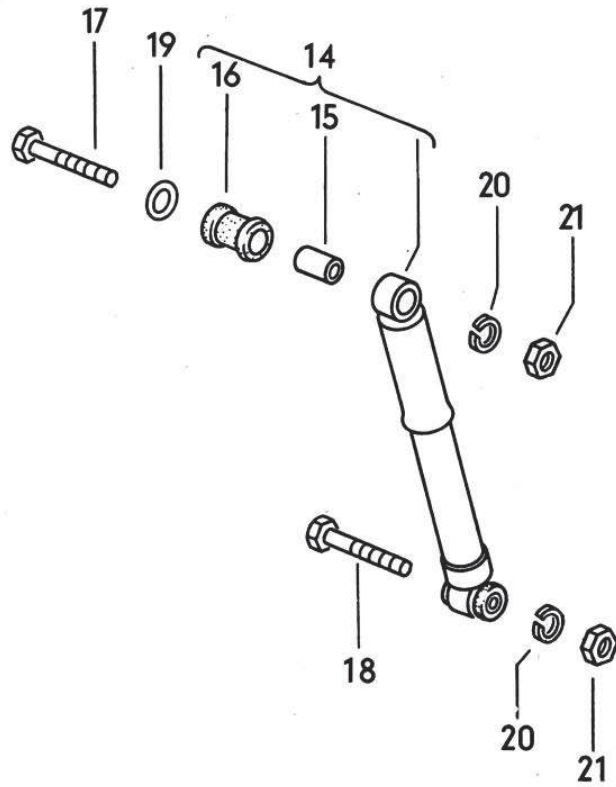
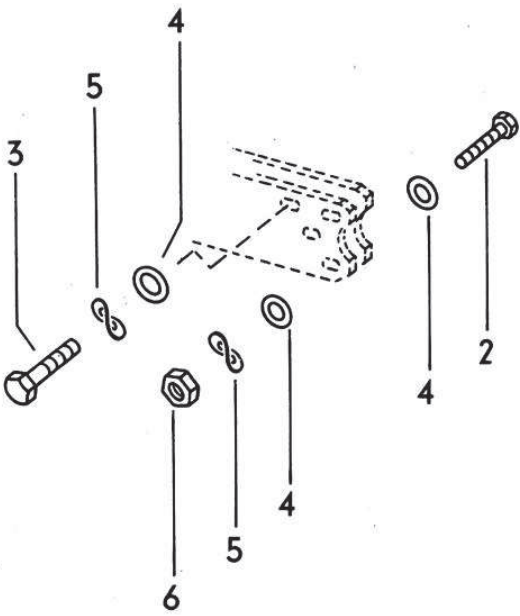
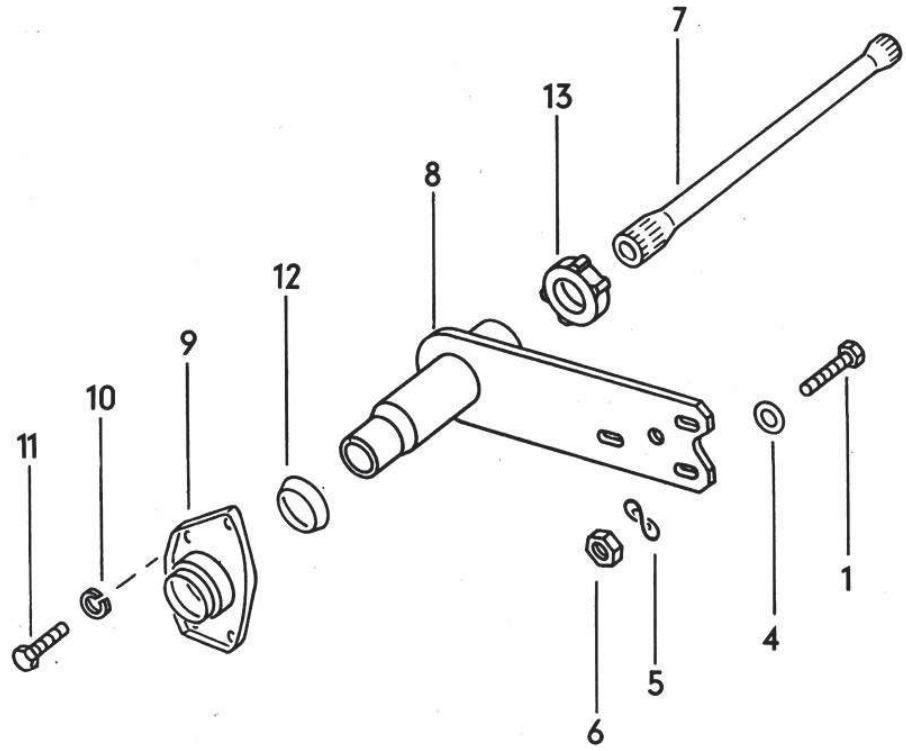

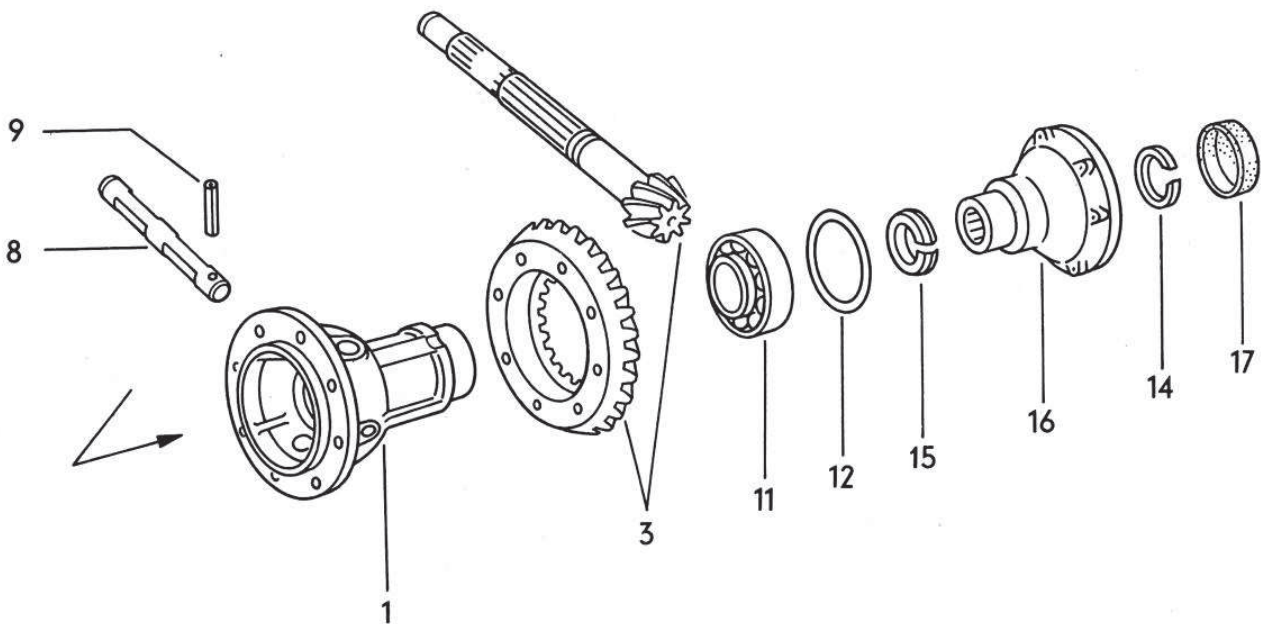
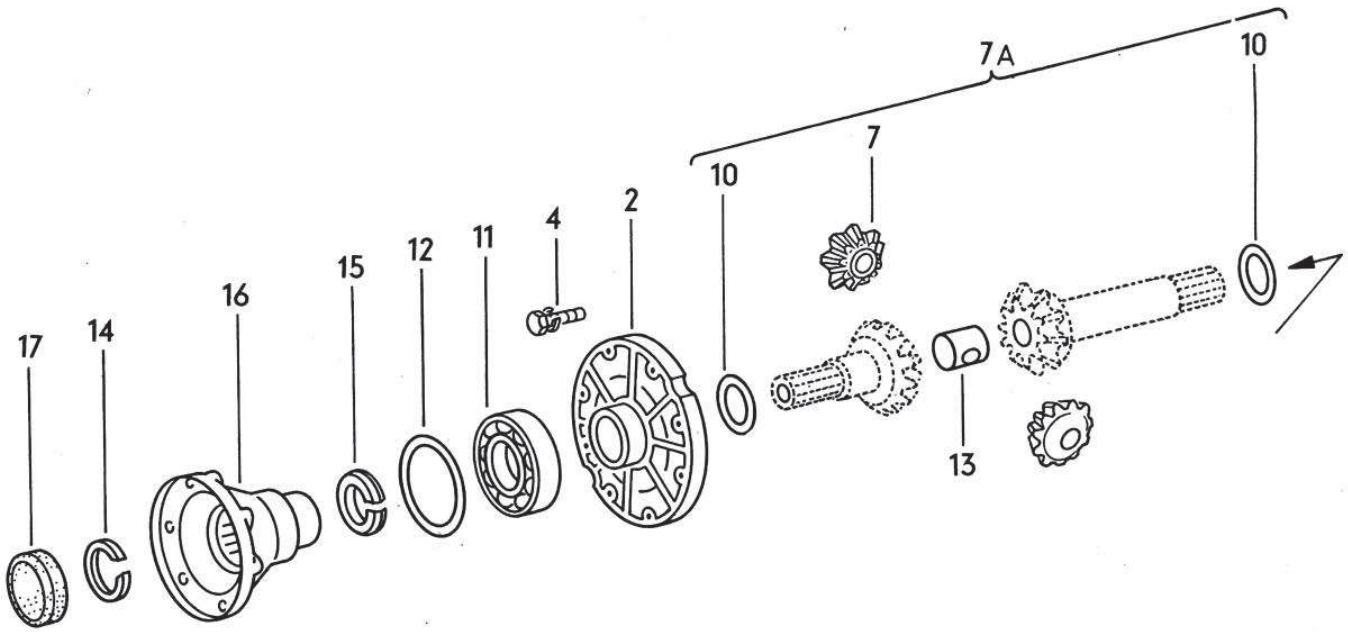

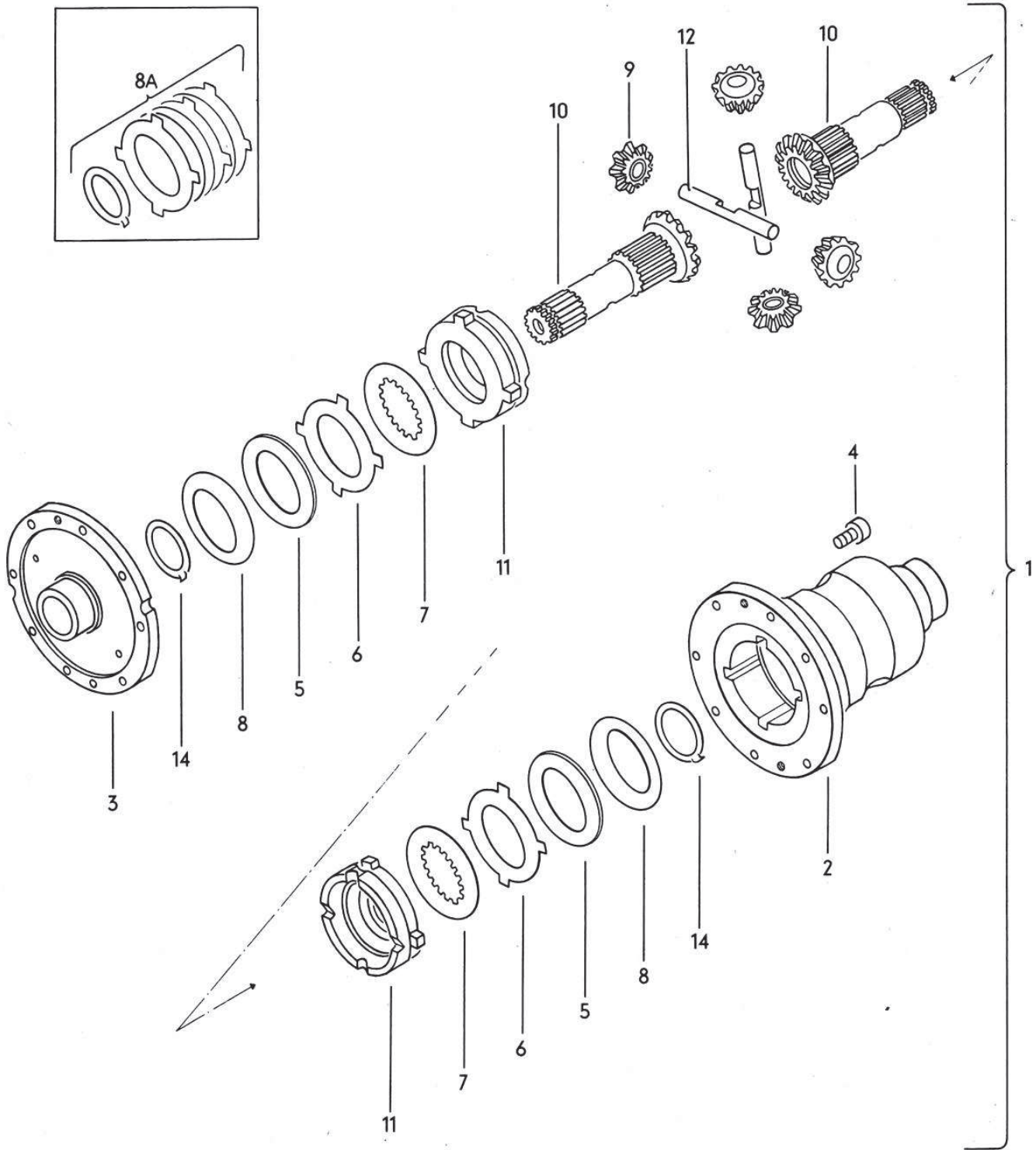
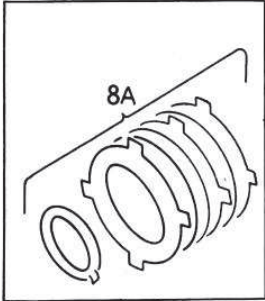
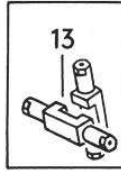

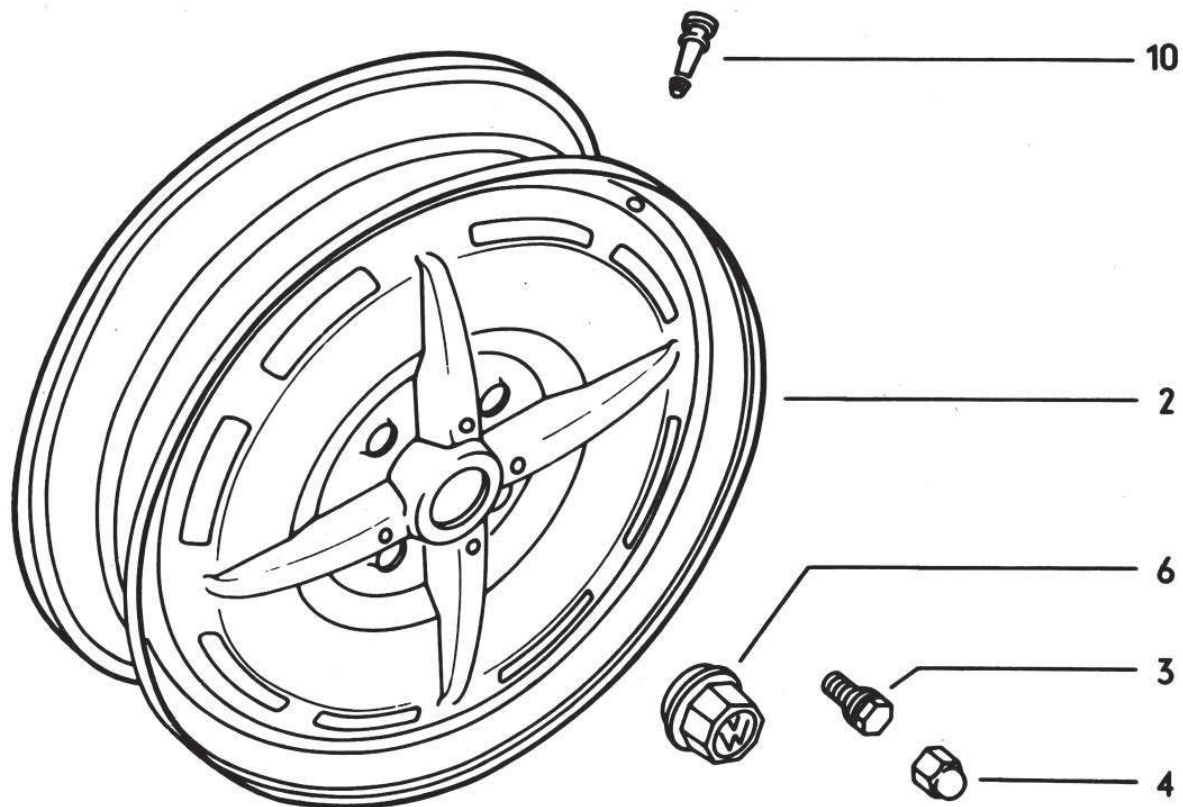
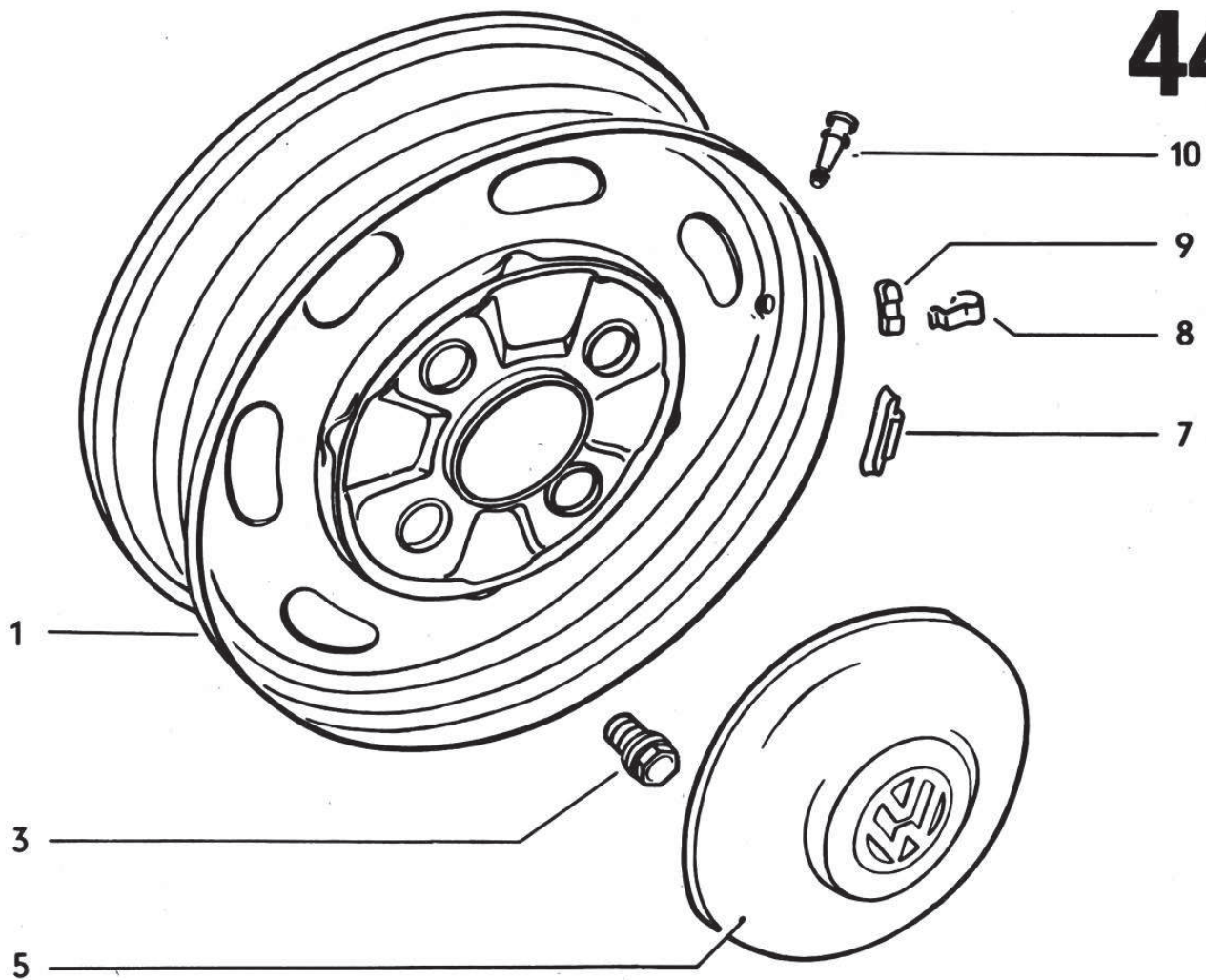

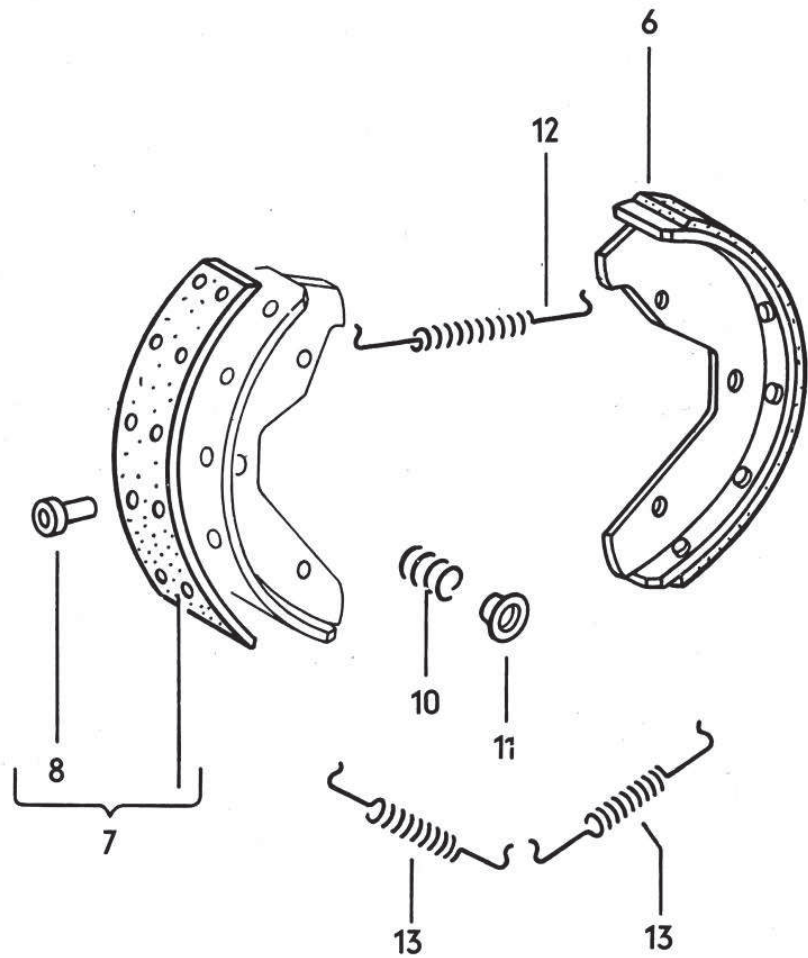
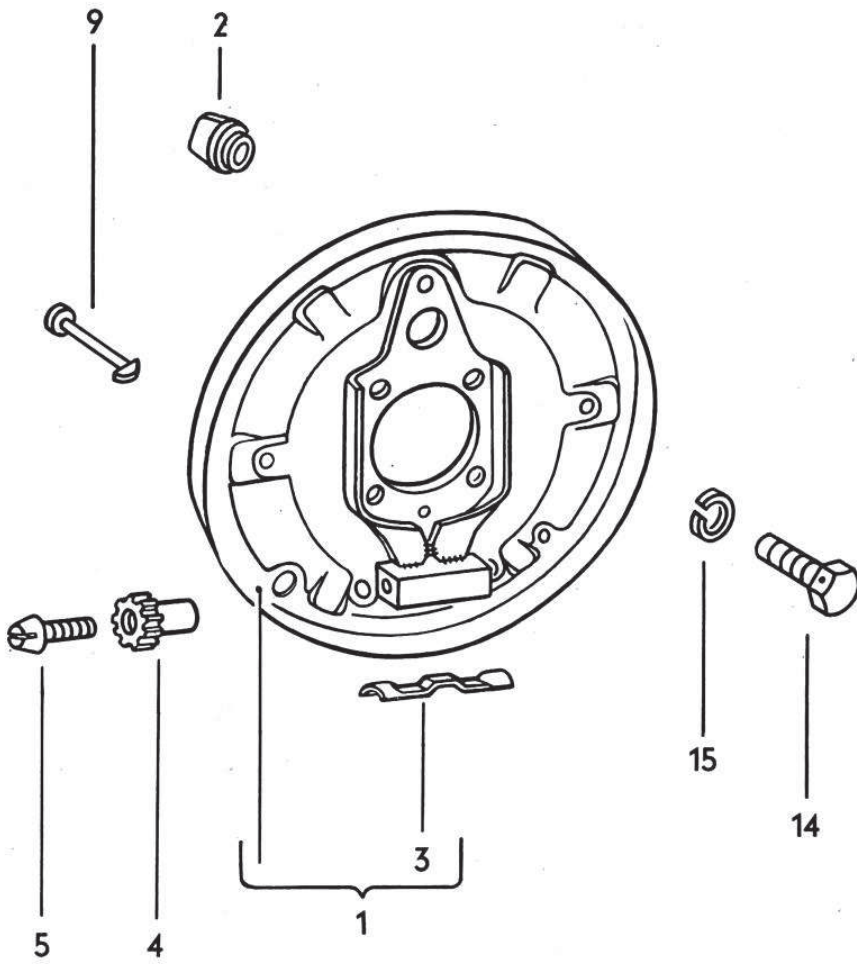

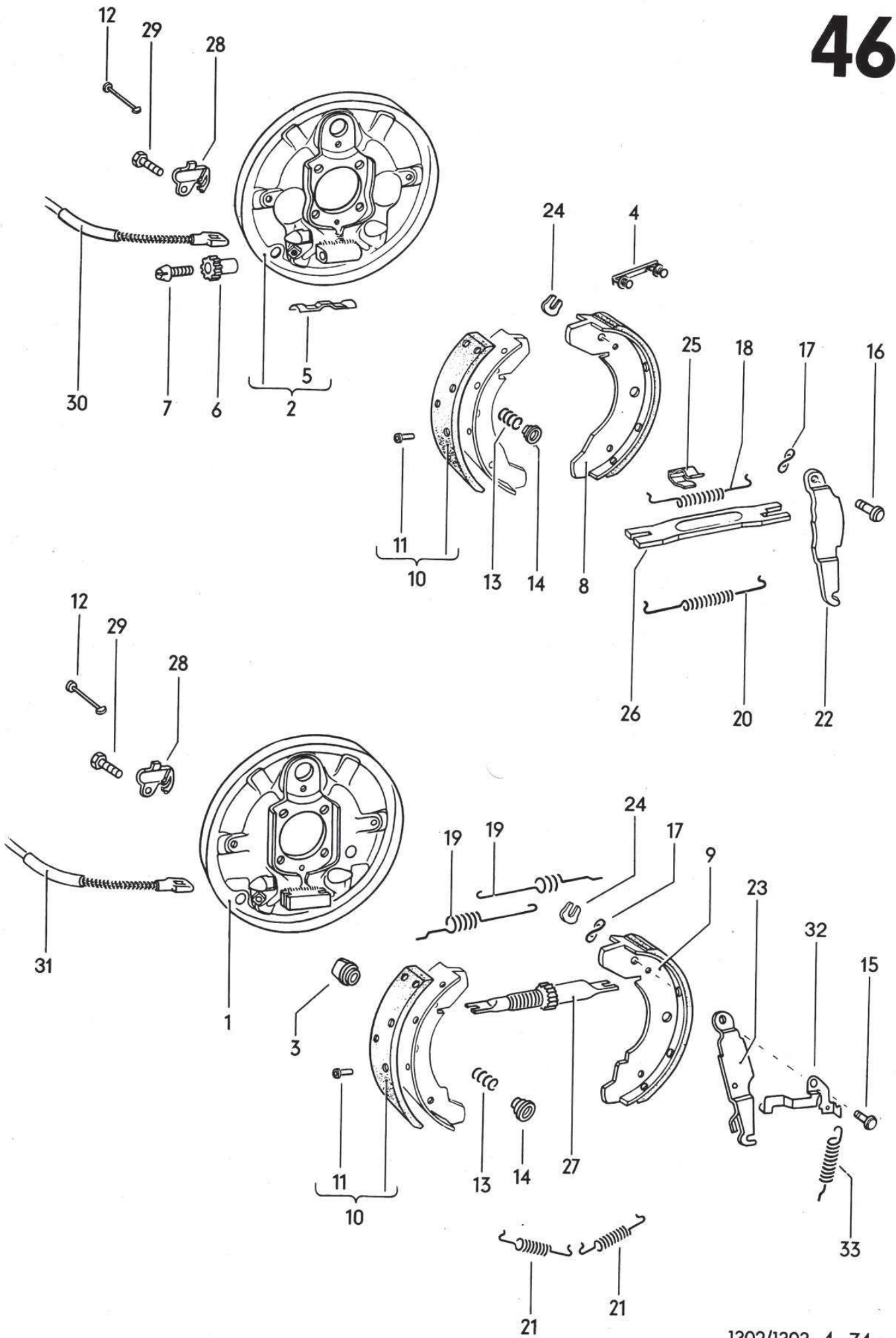

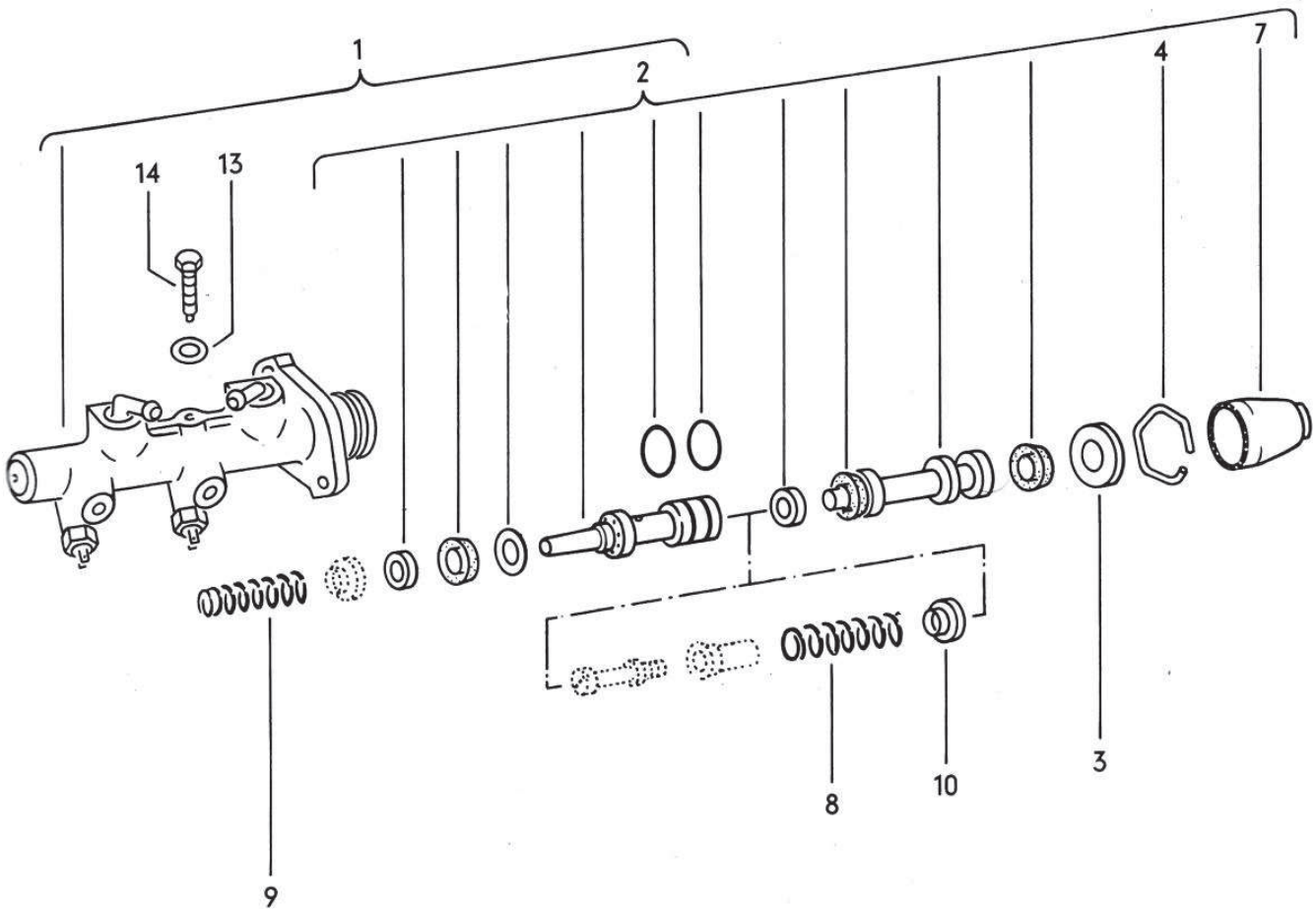
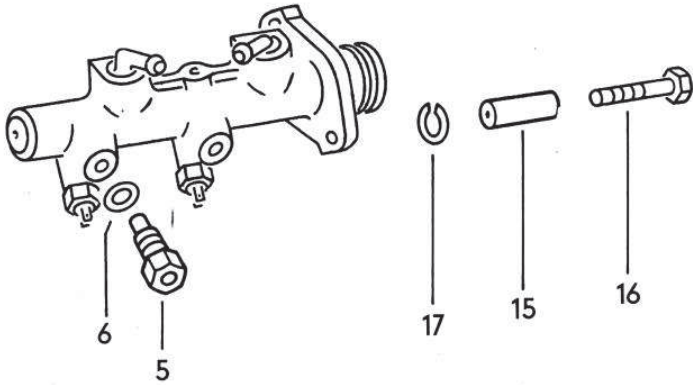

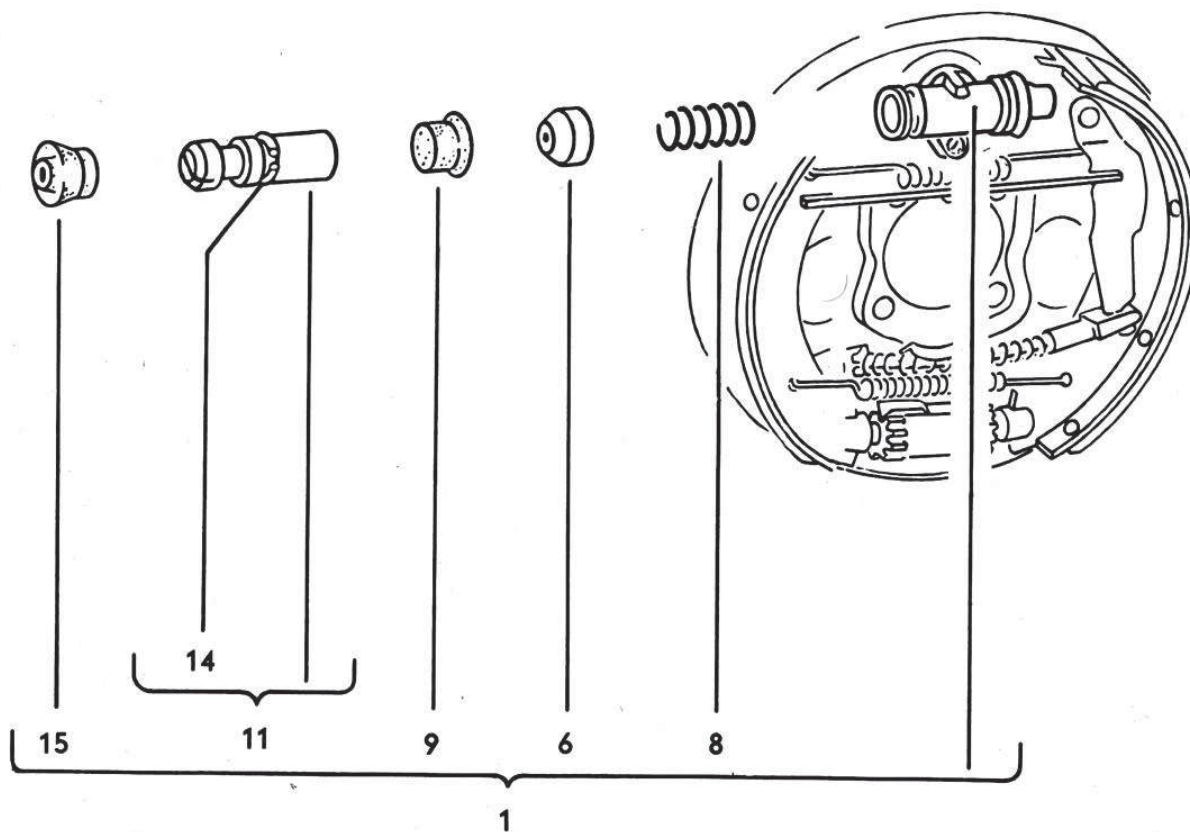
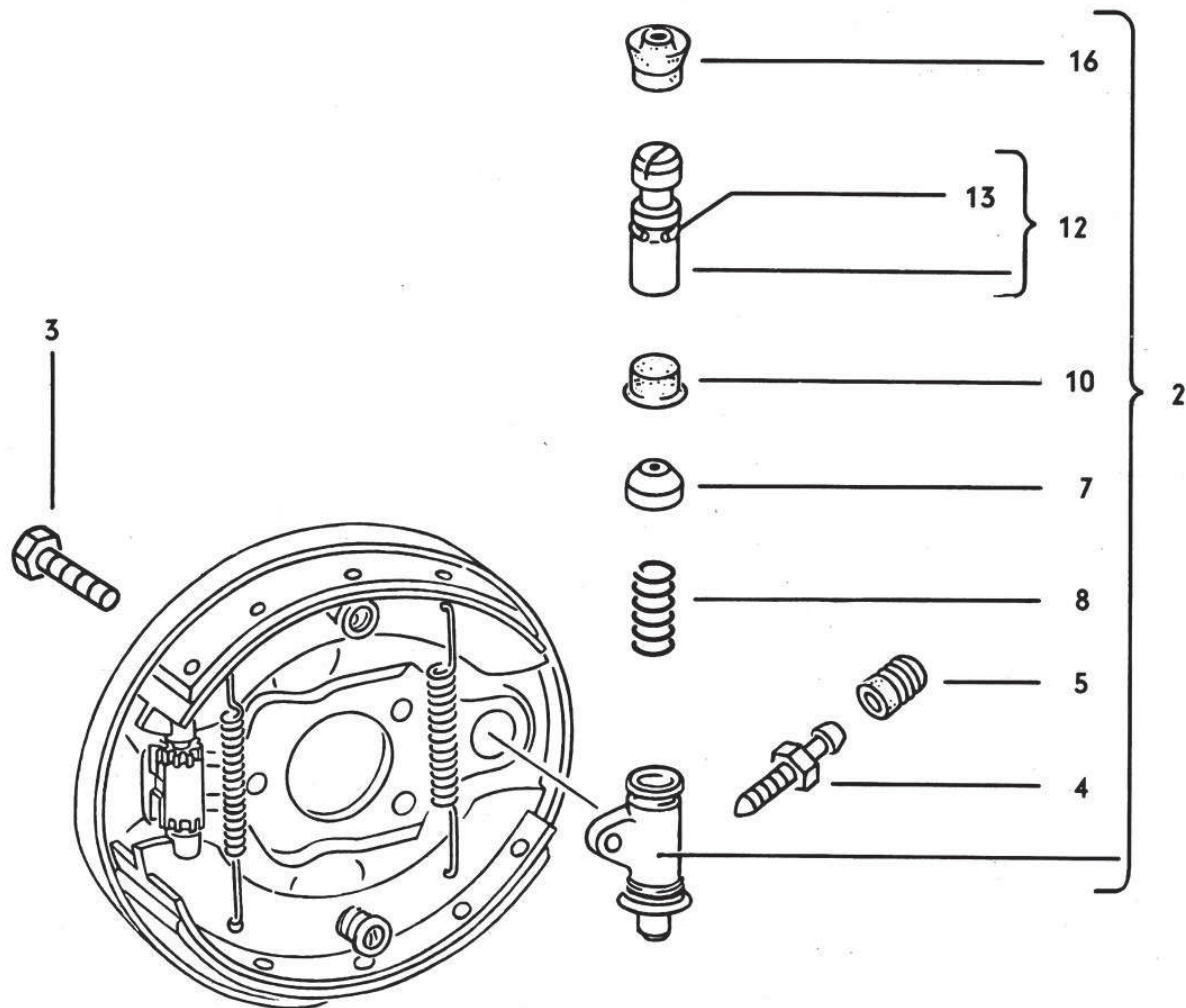

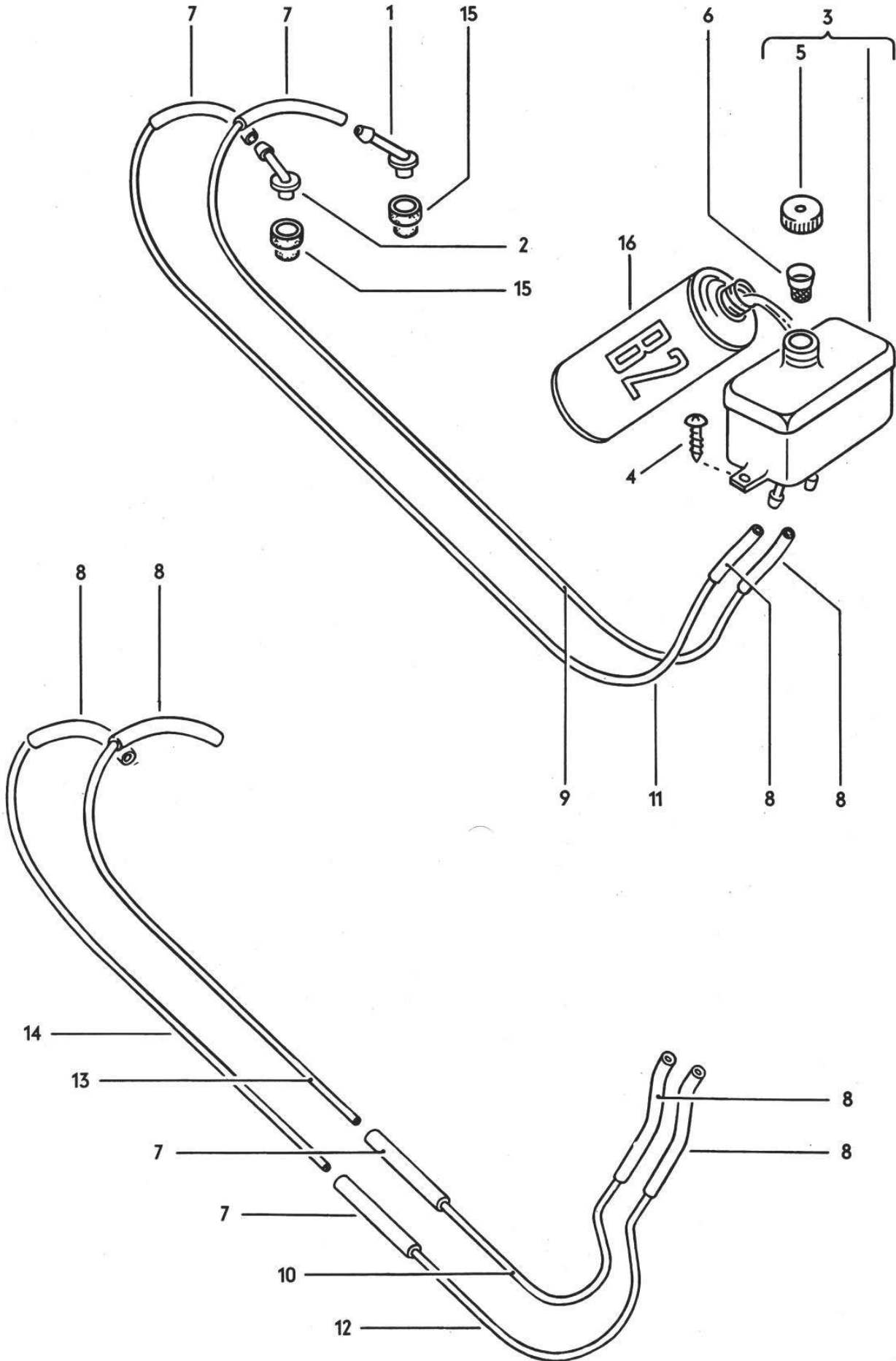

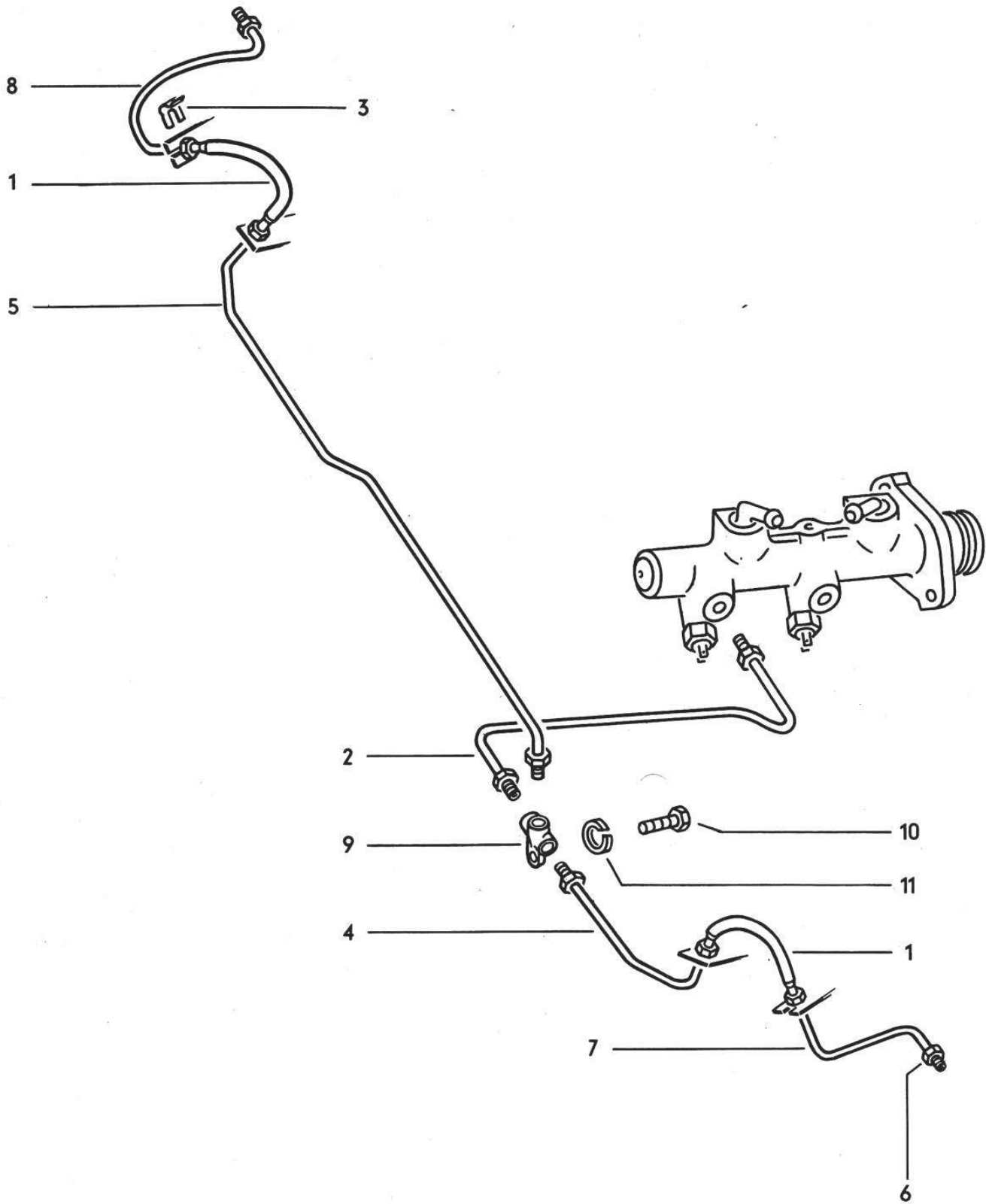

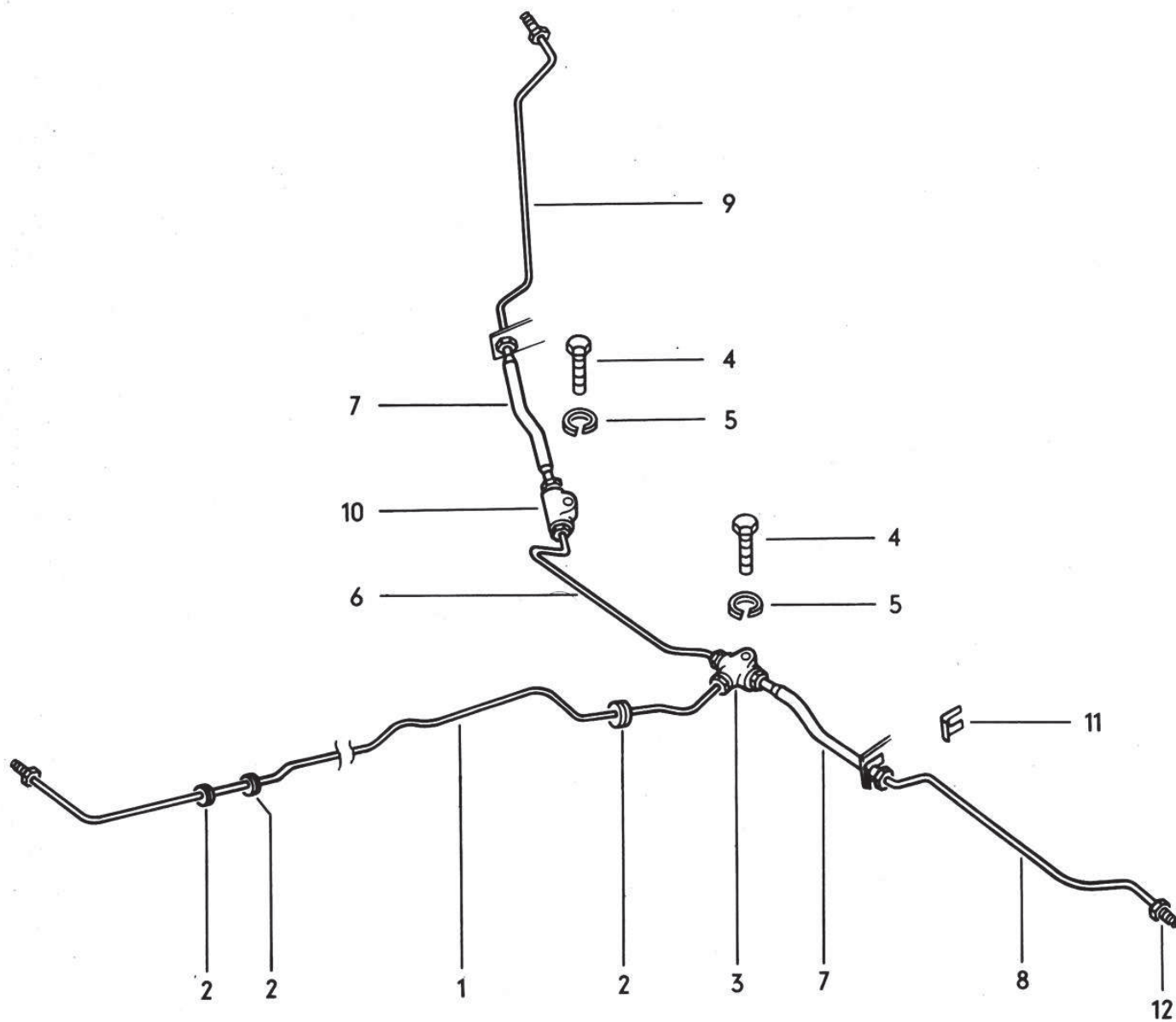

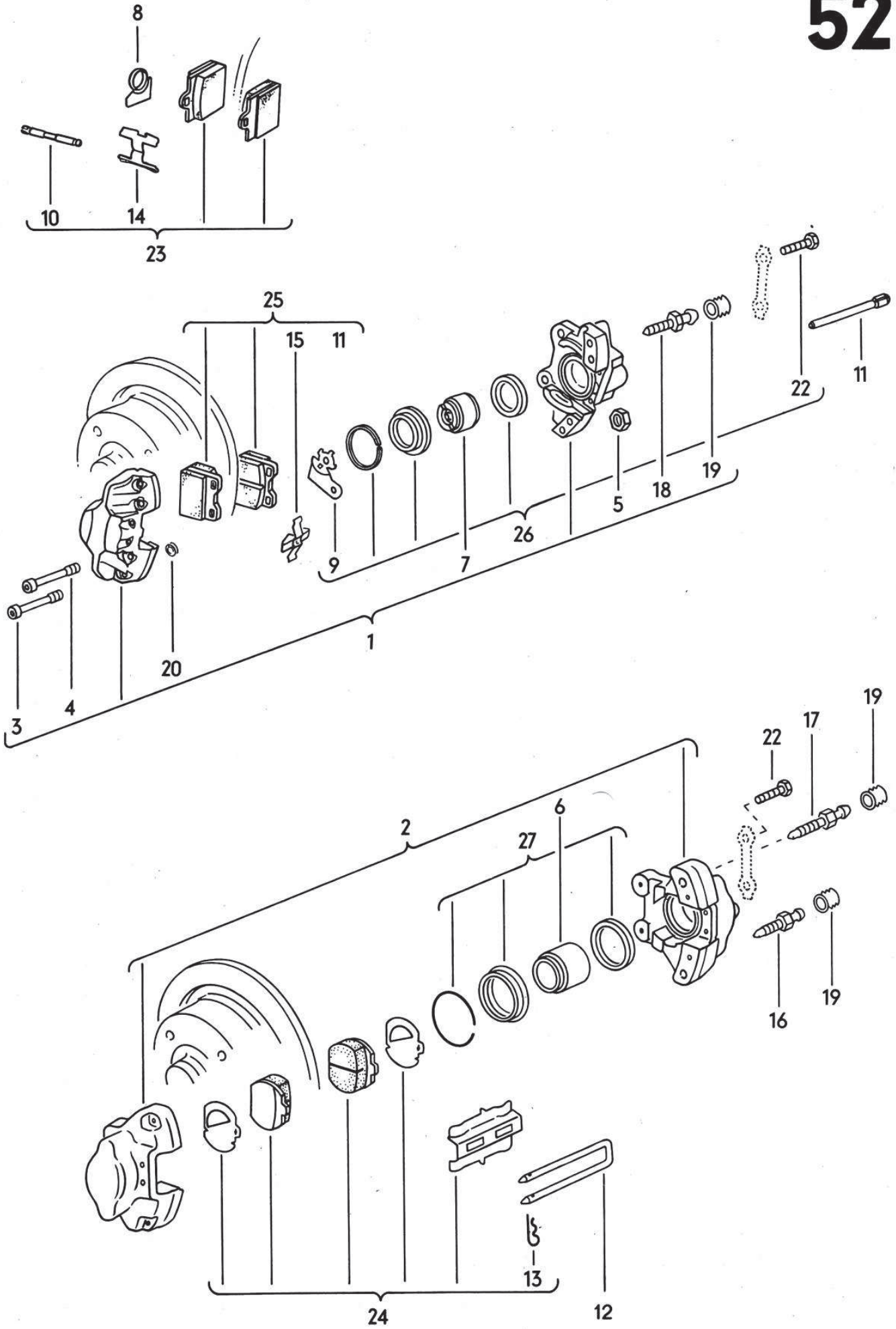

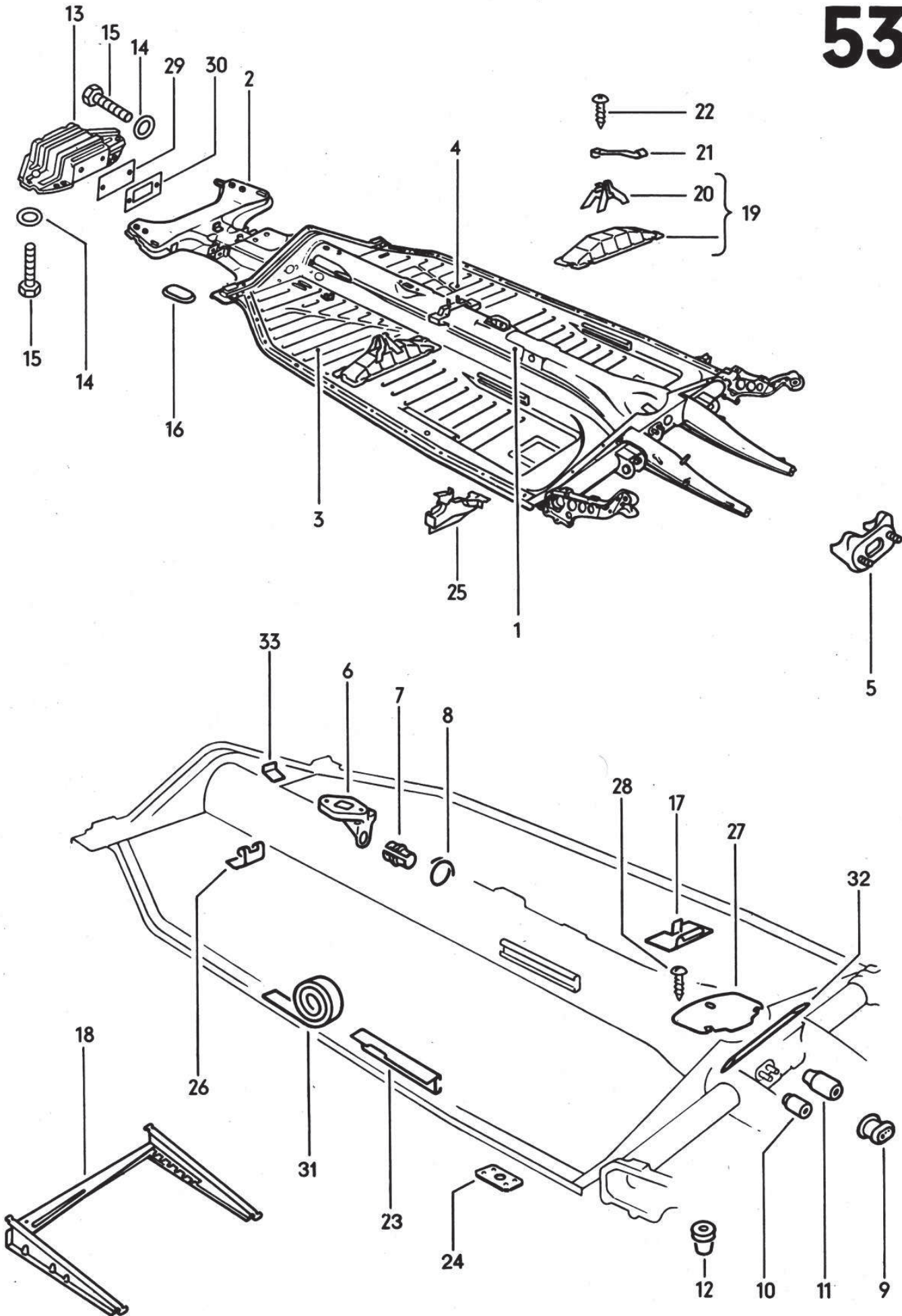

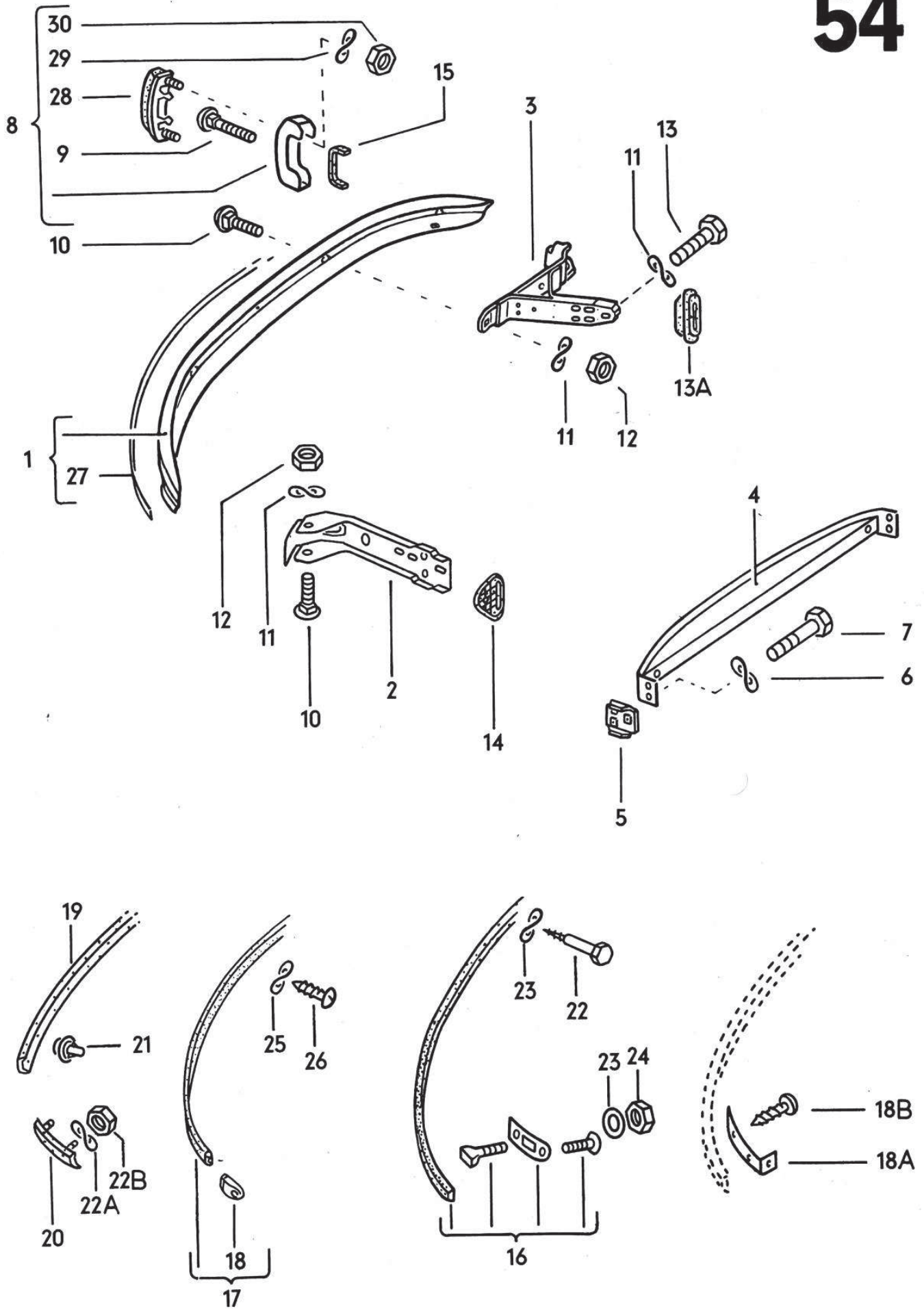

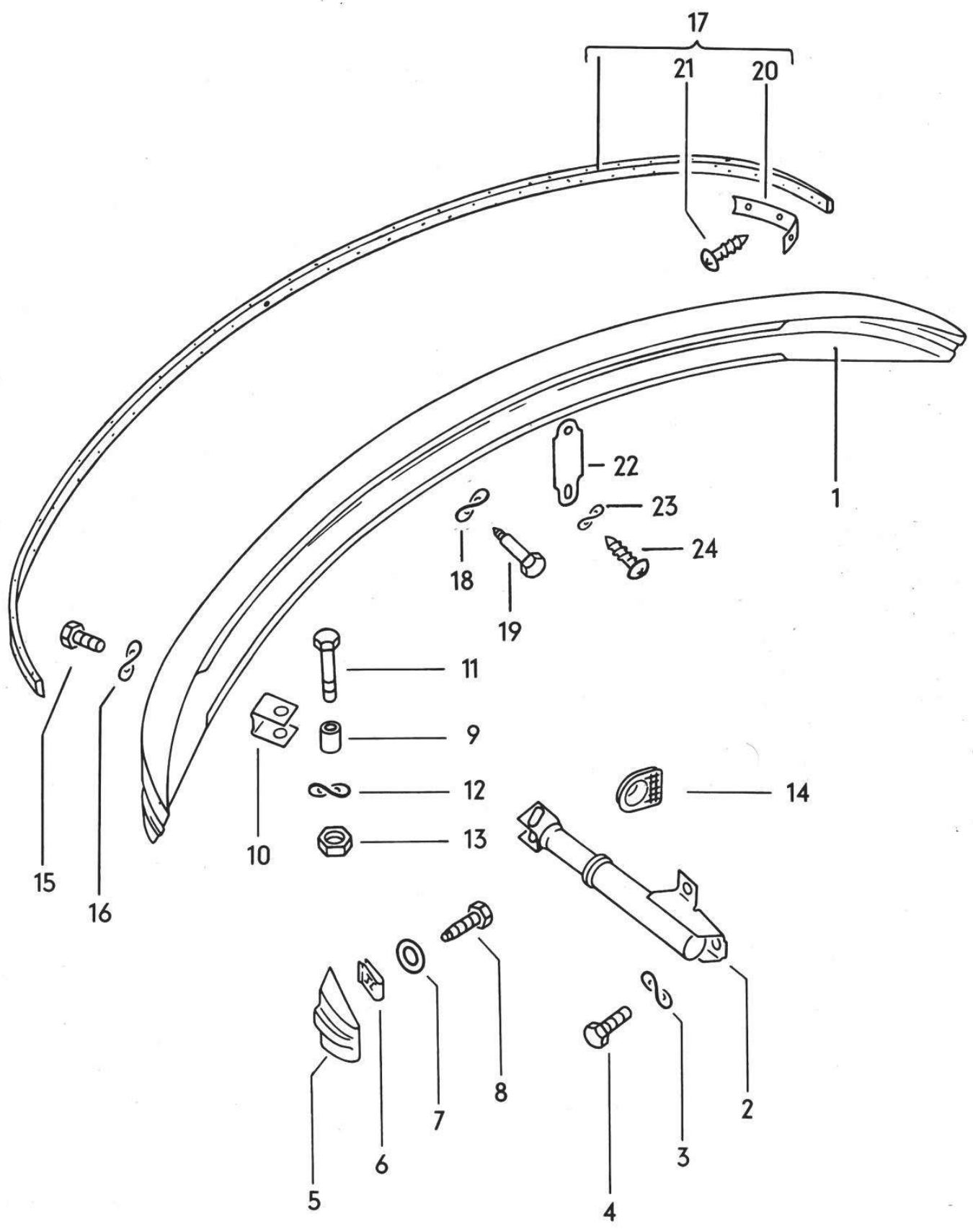

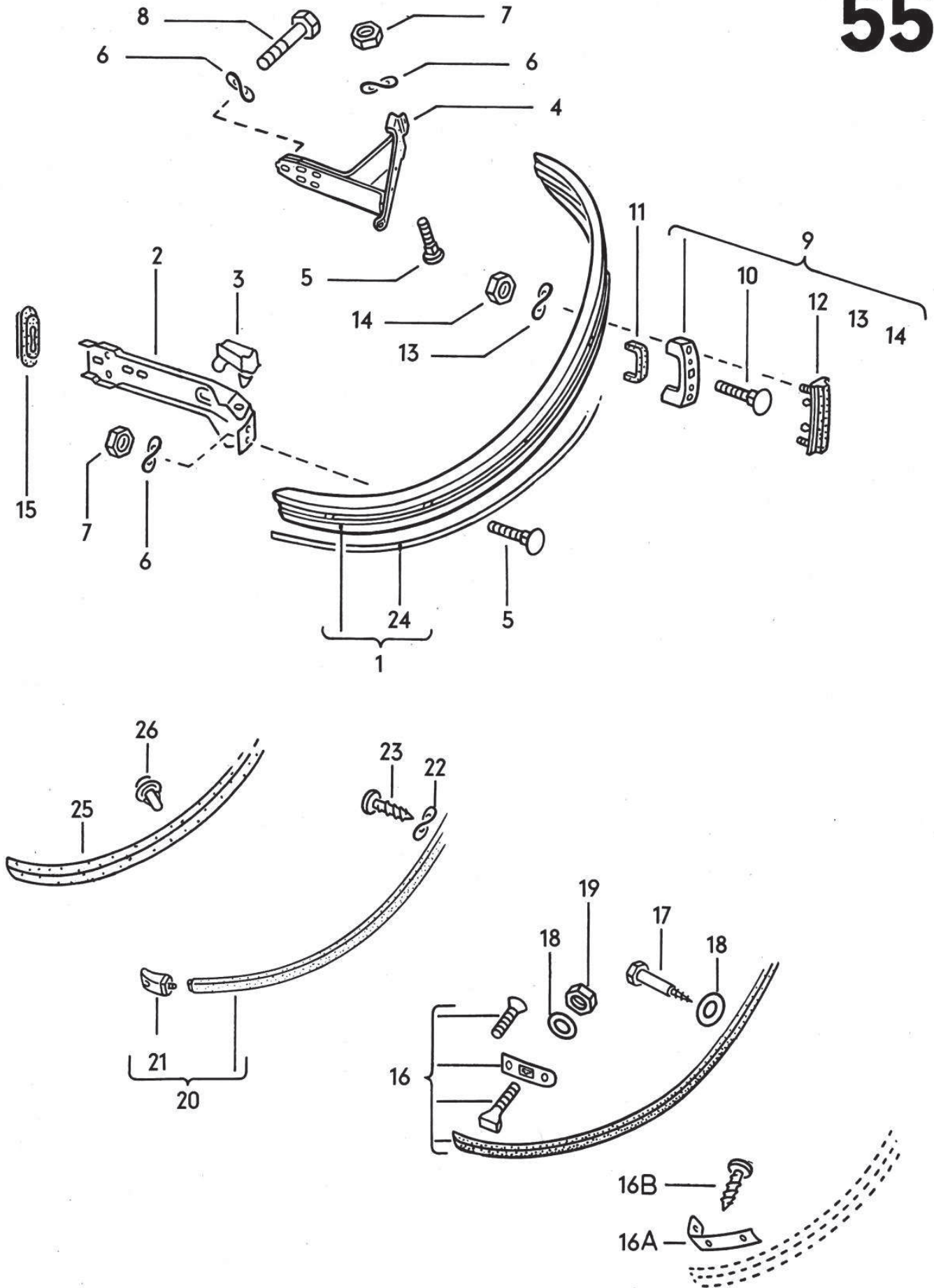

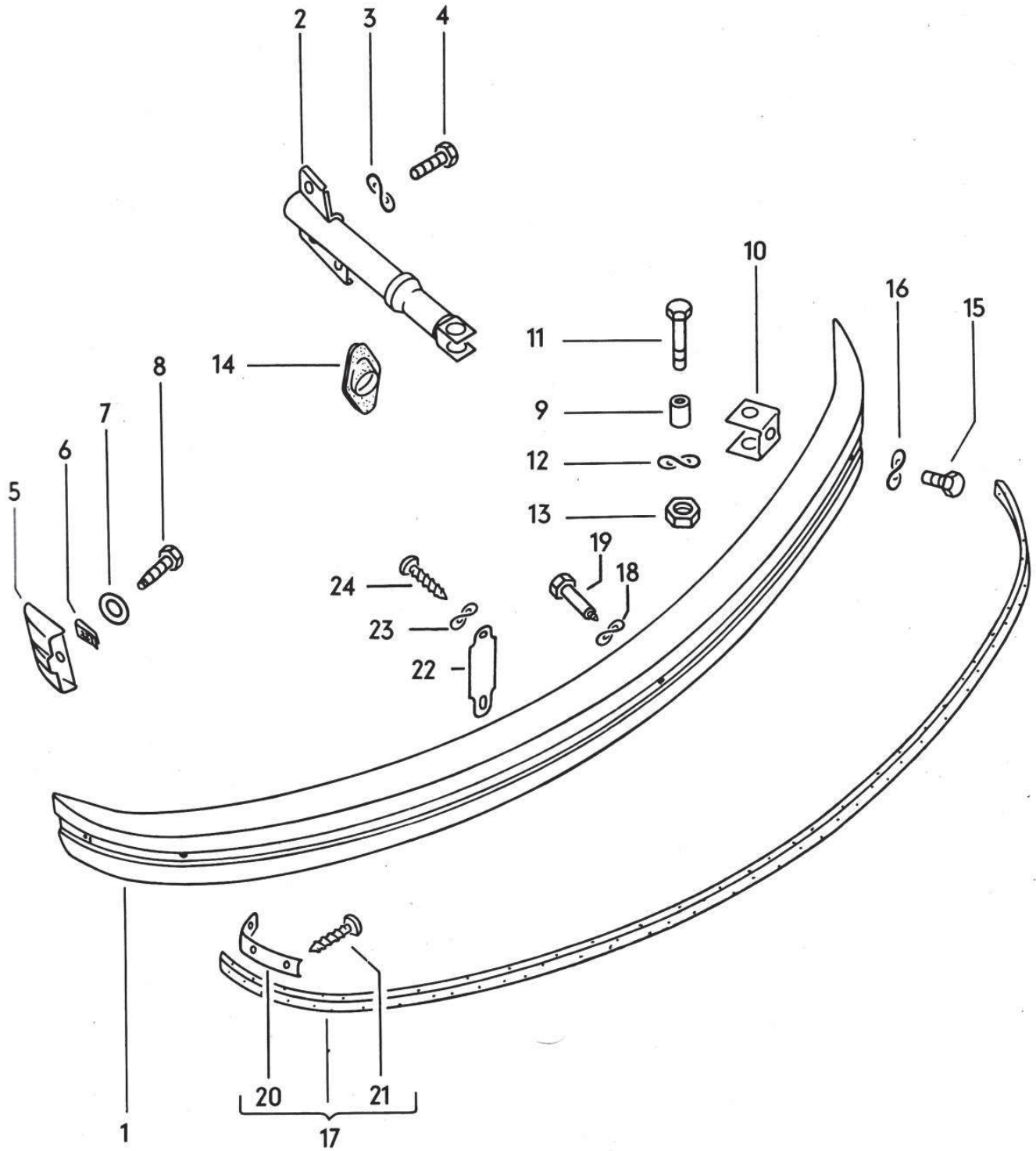

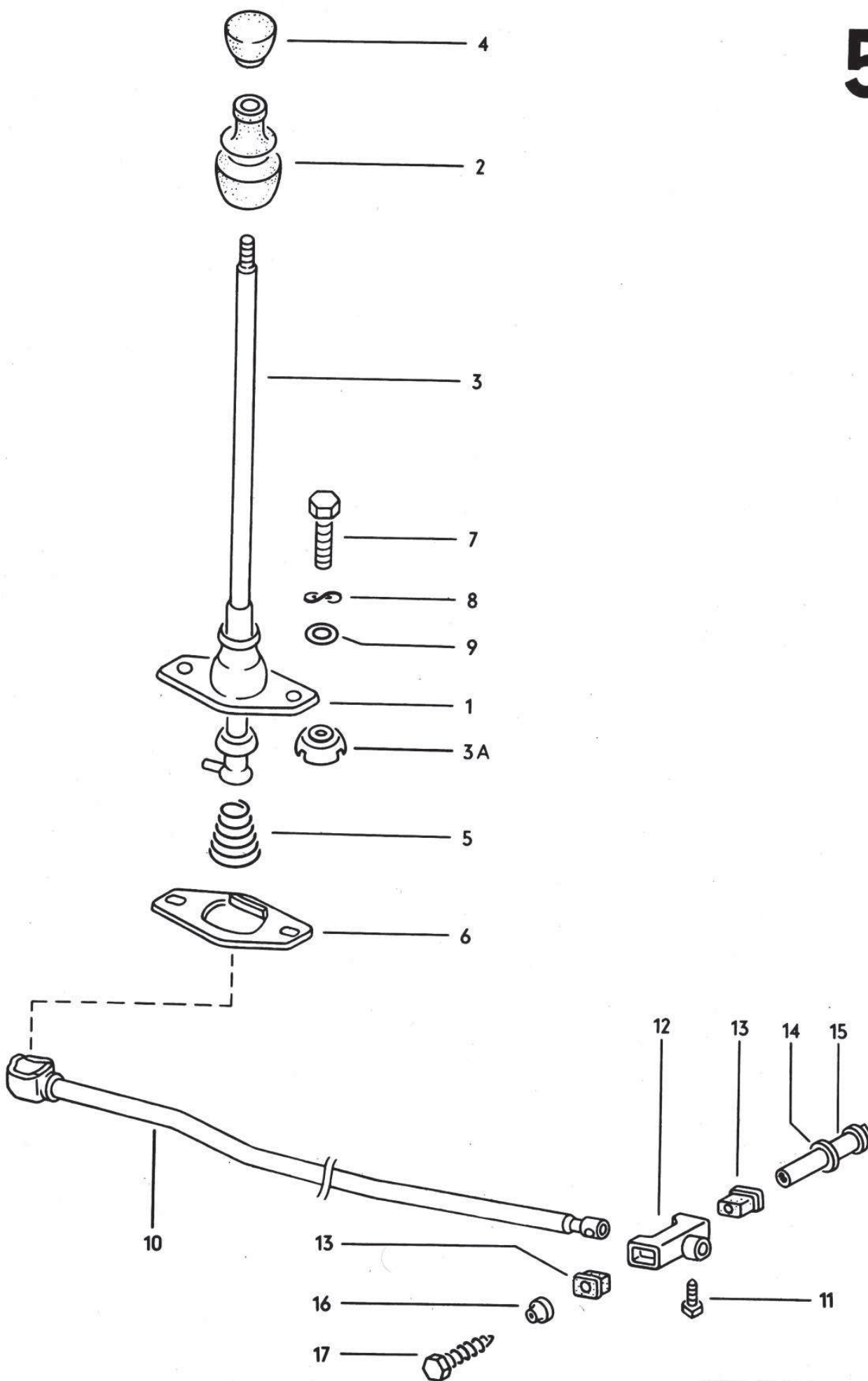

1302/1303

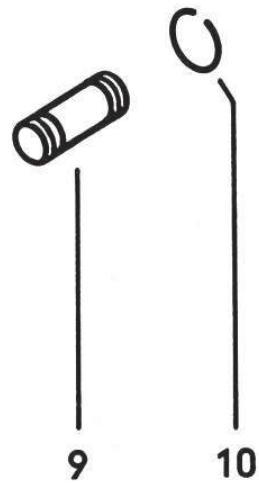
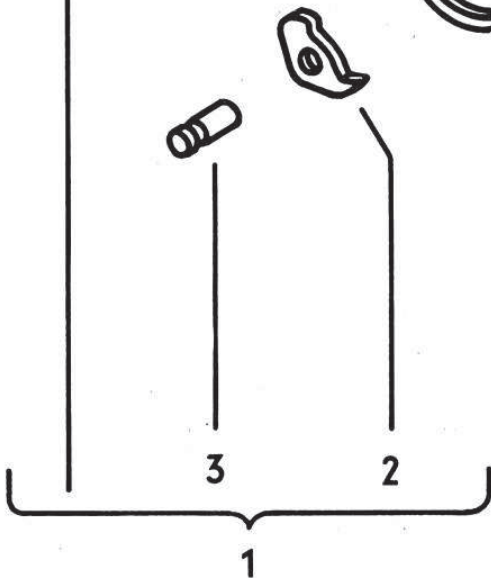
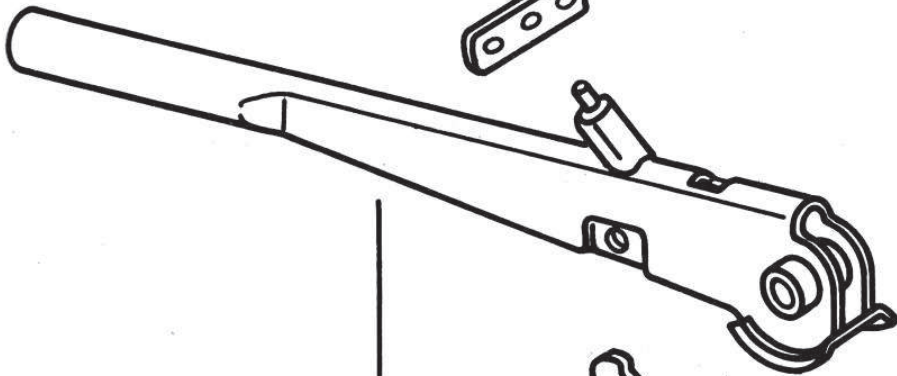
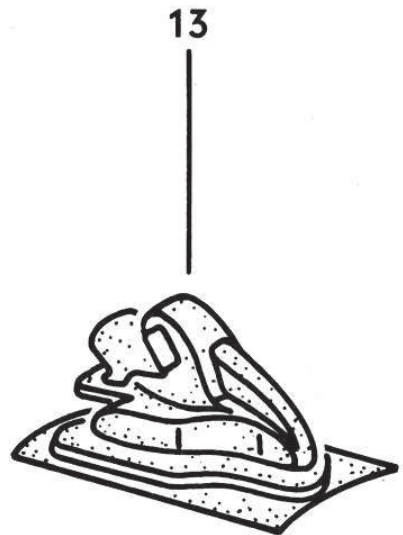
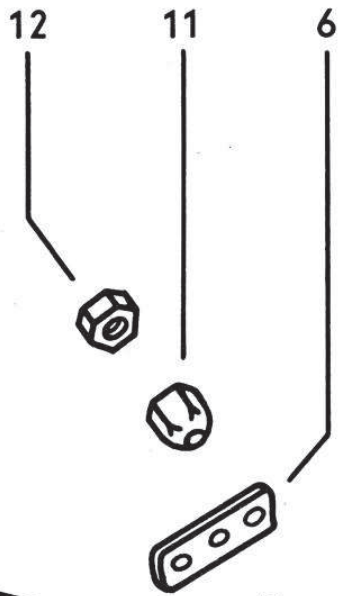
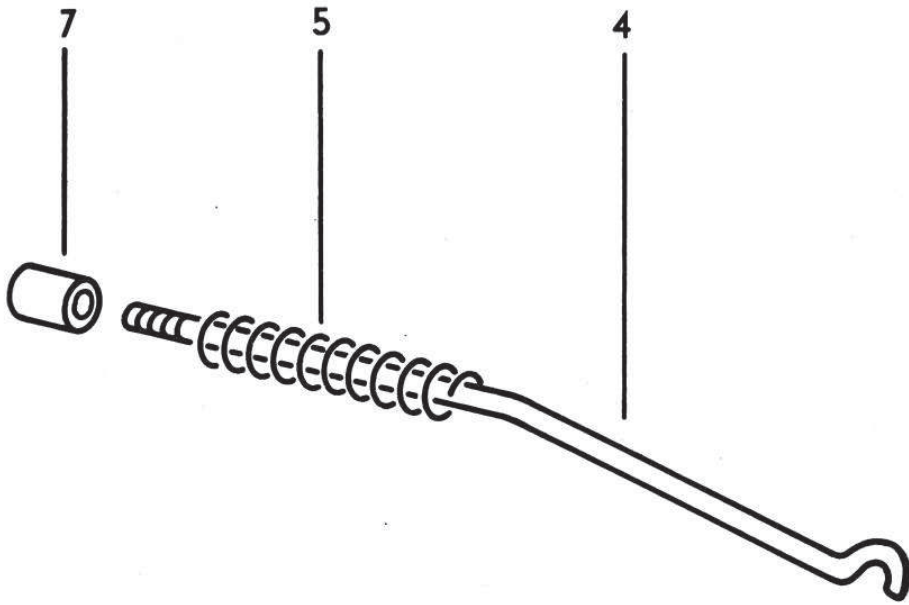

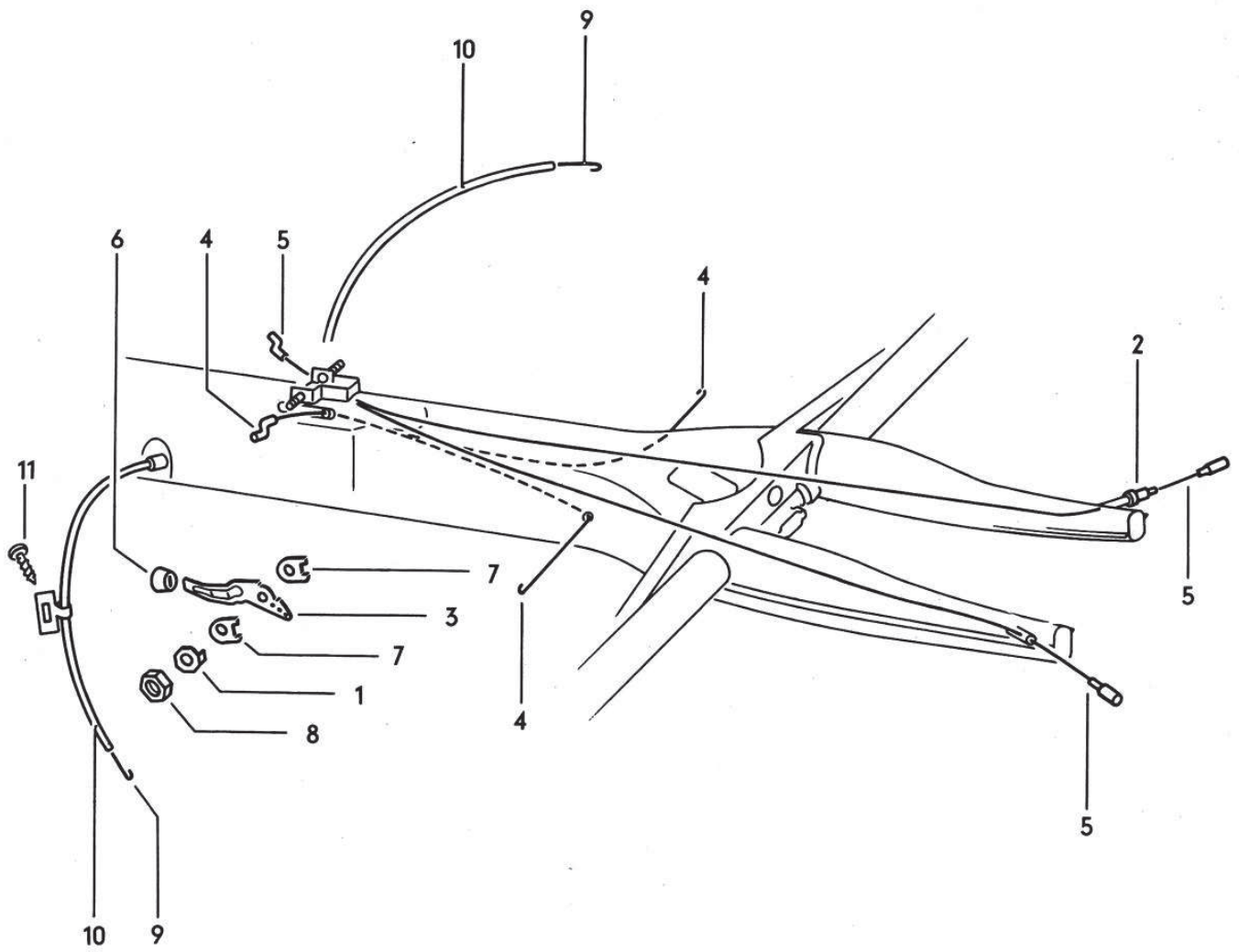

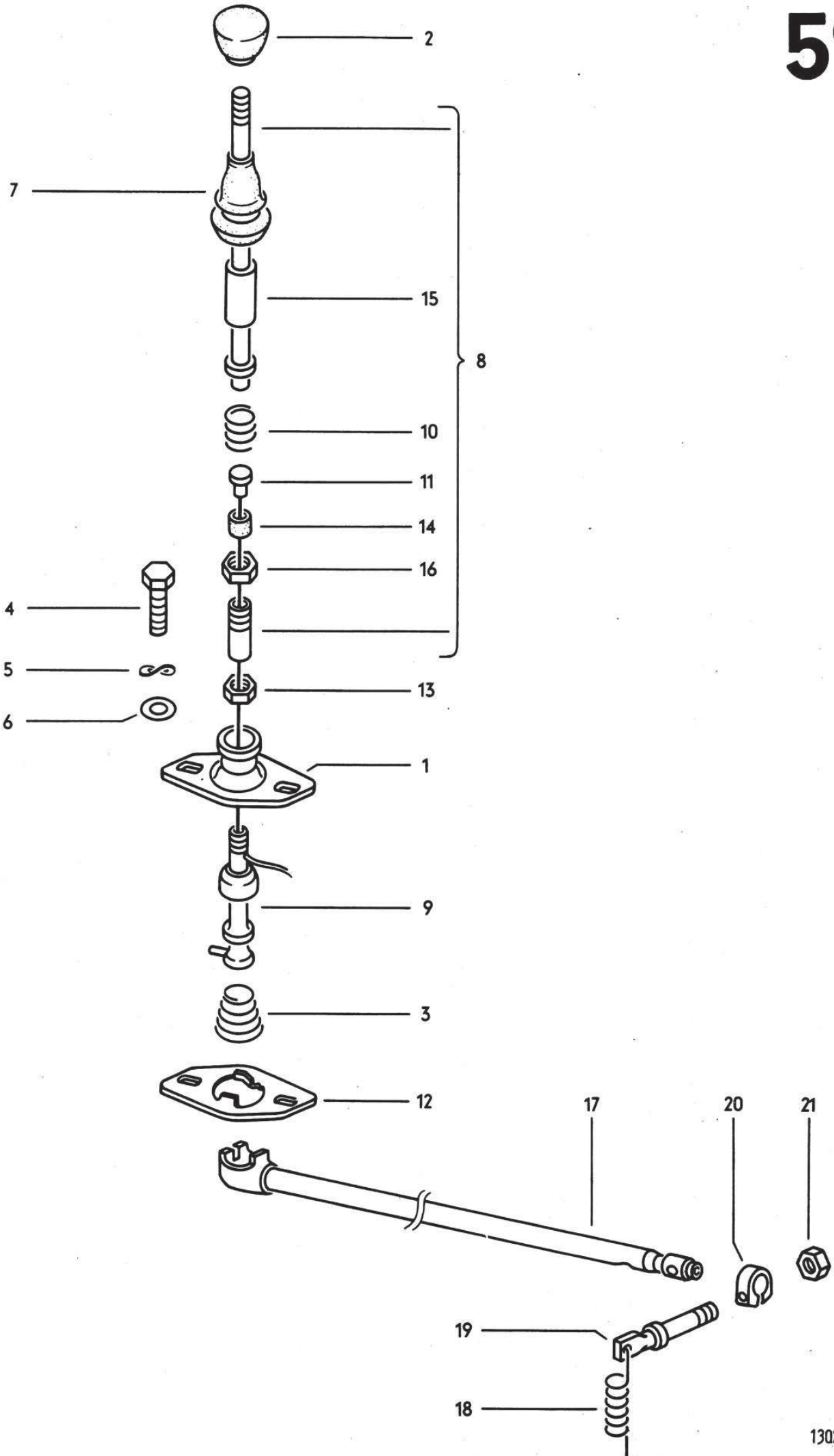

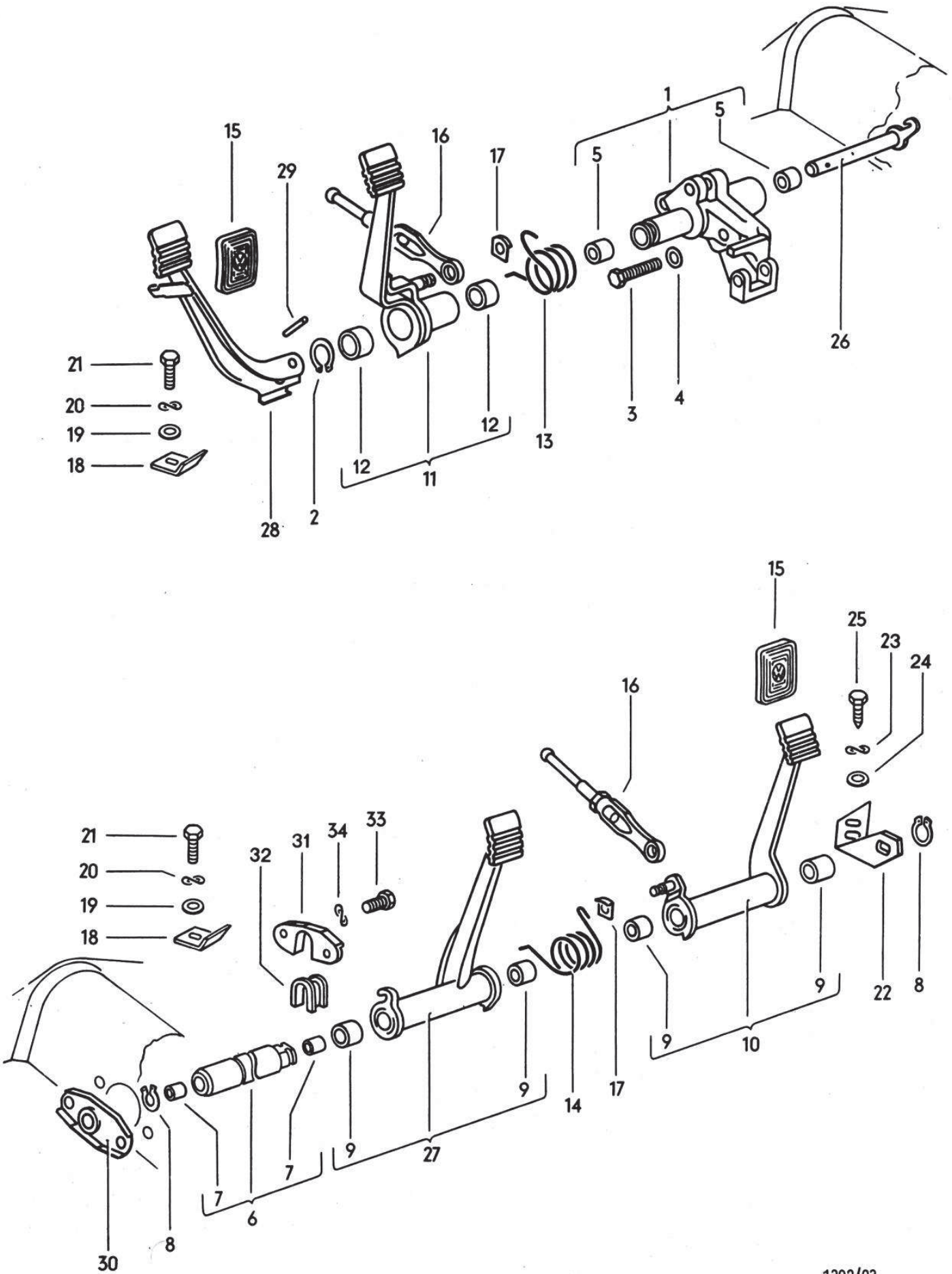

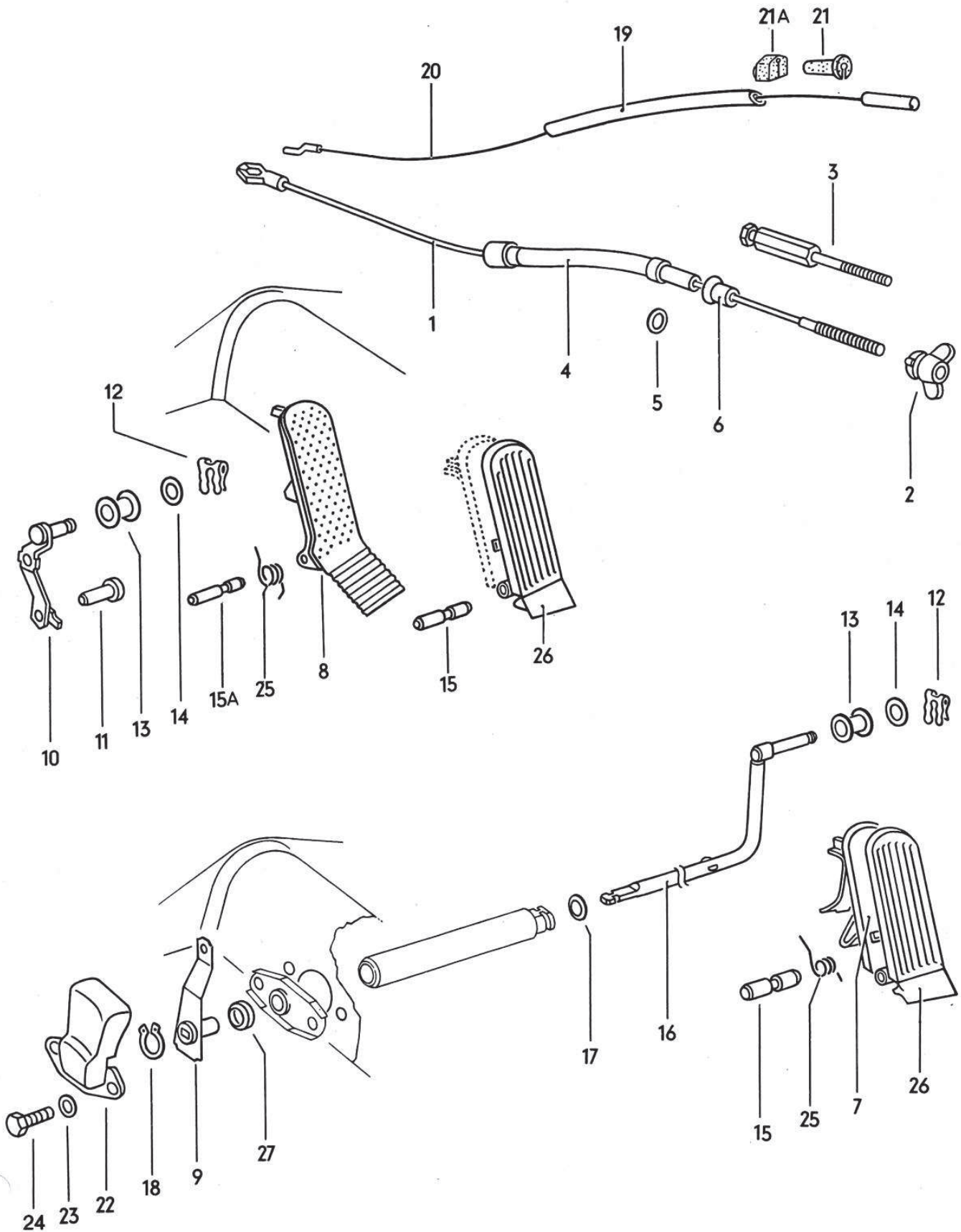

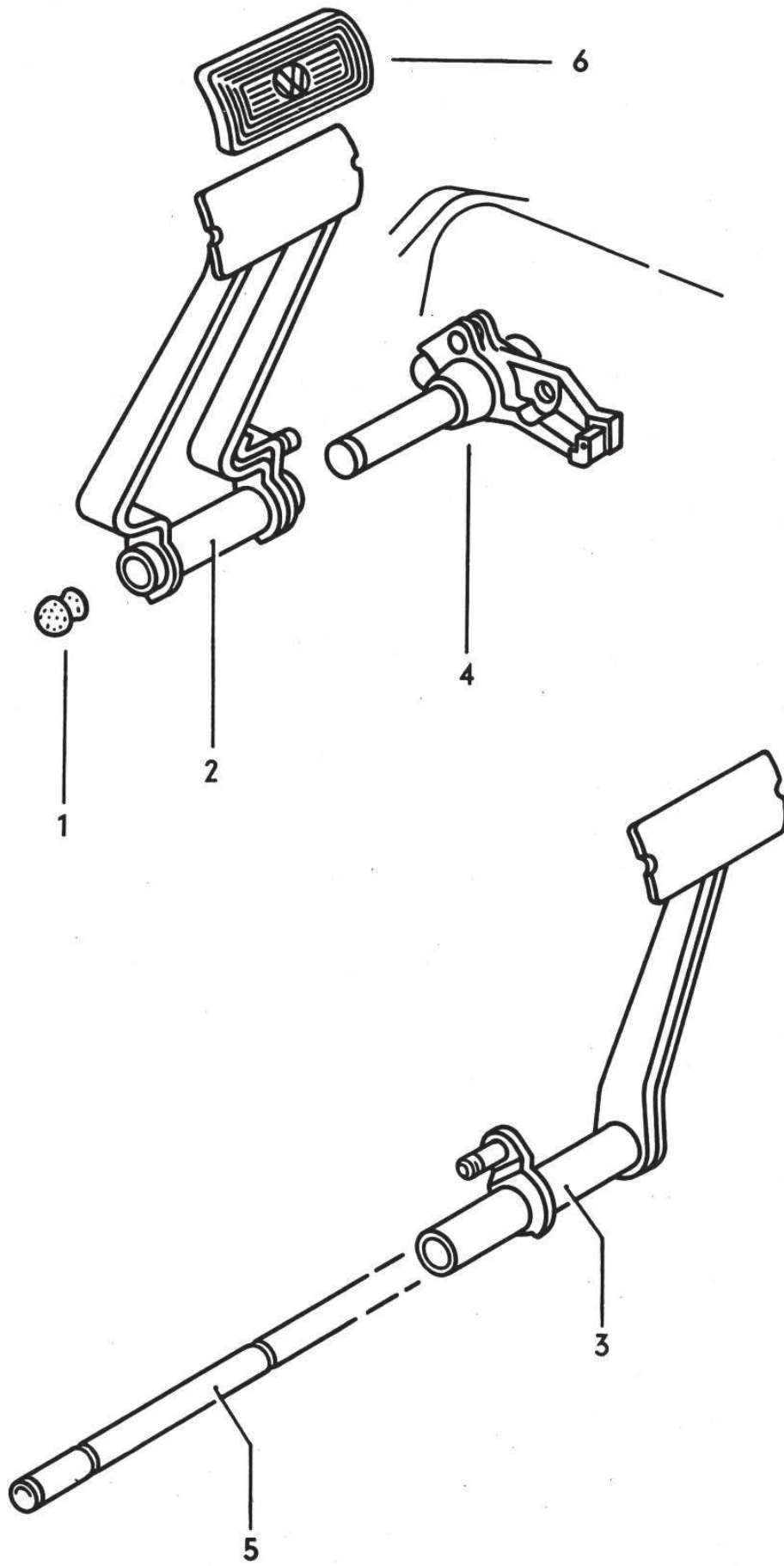

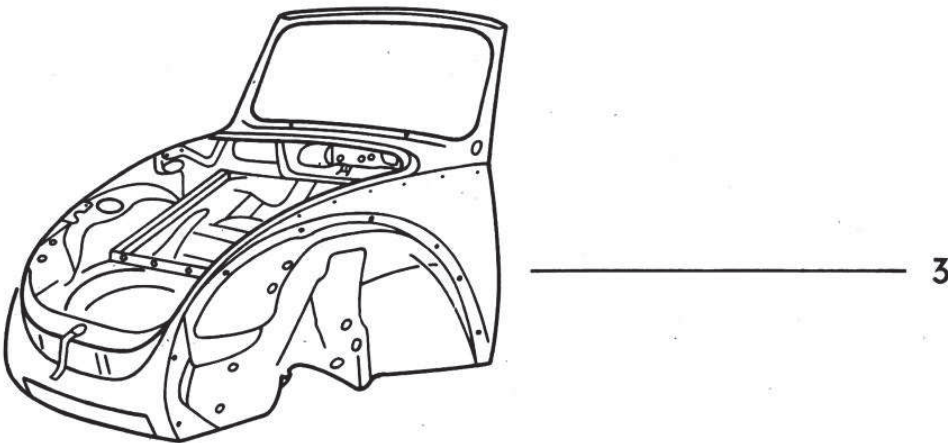
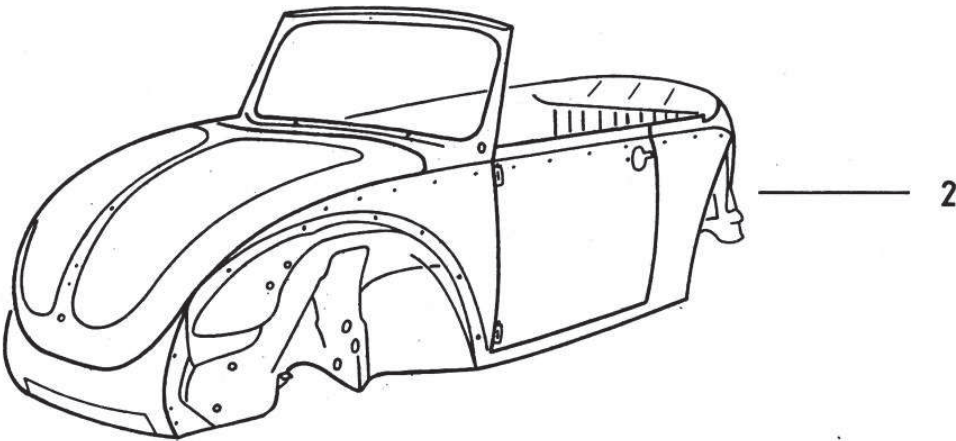
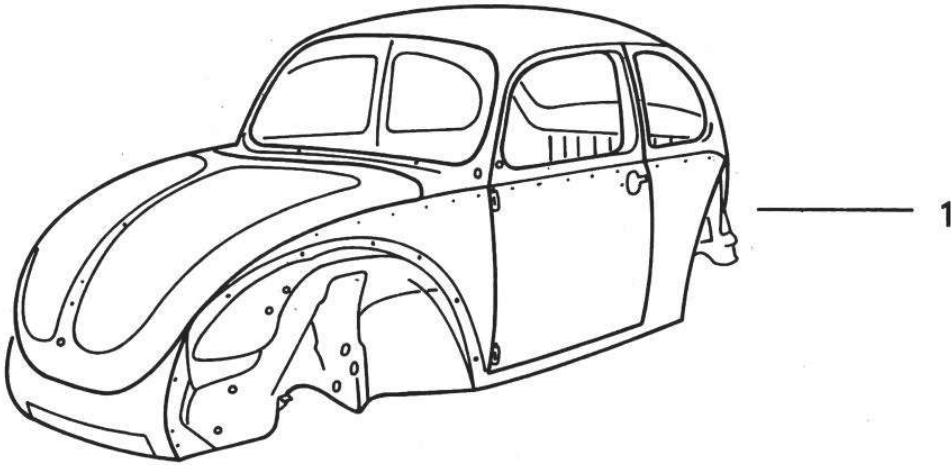

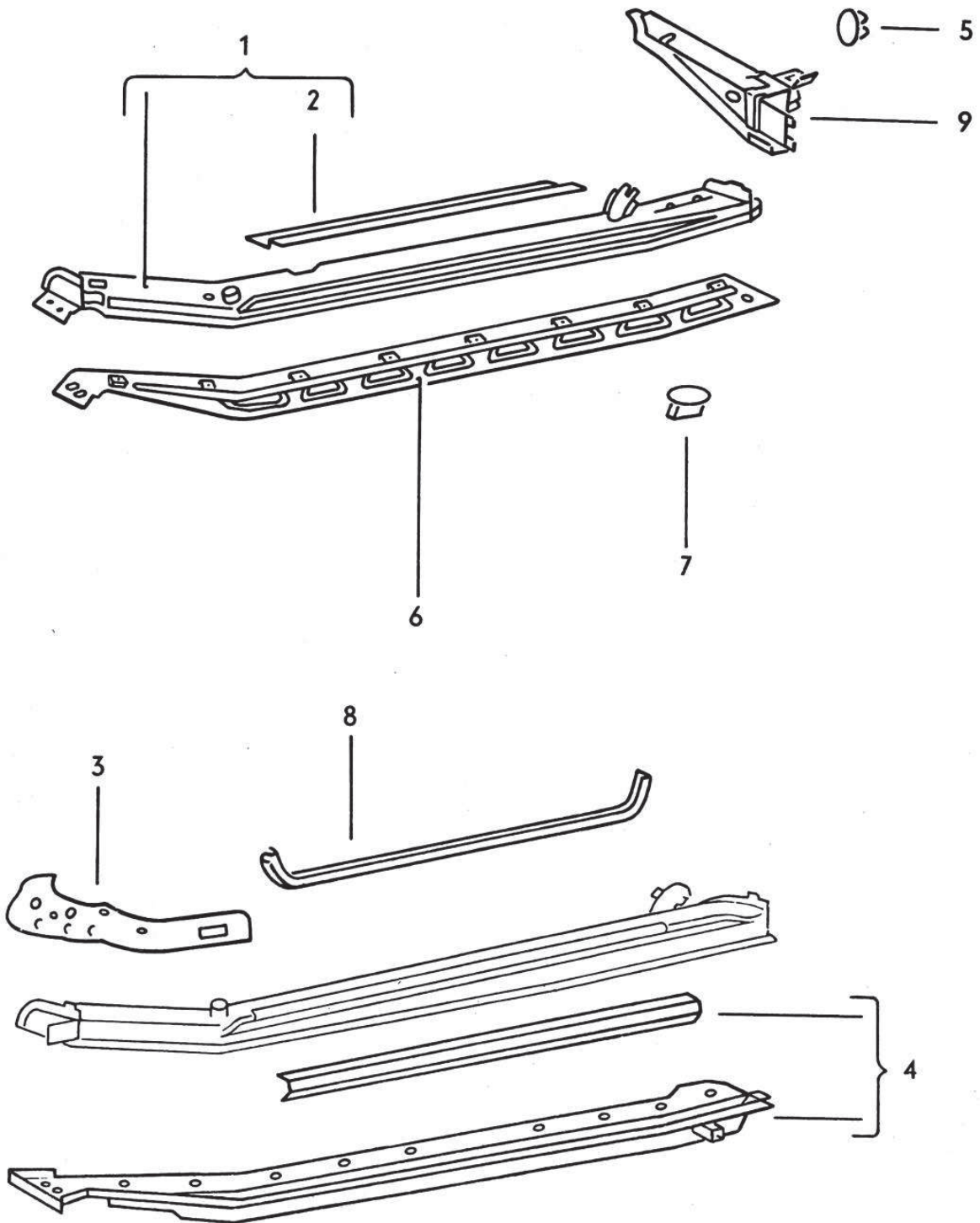

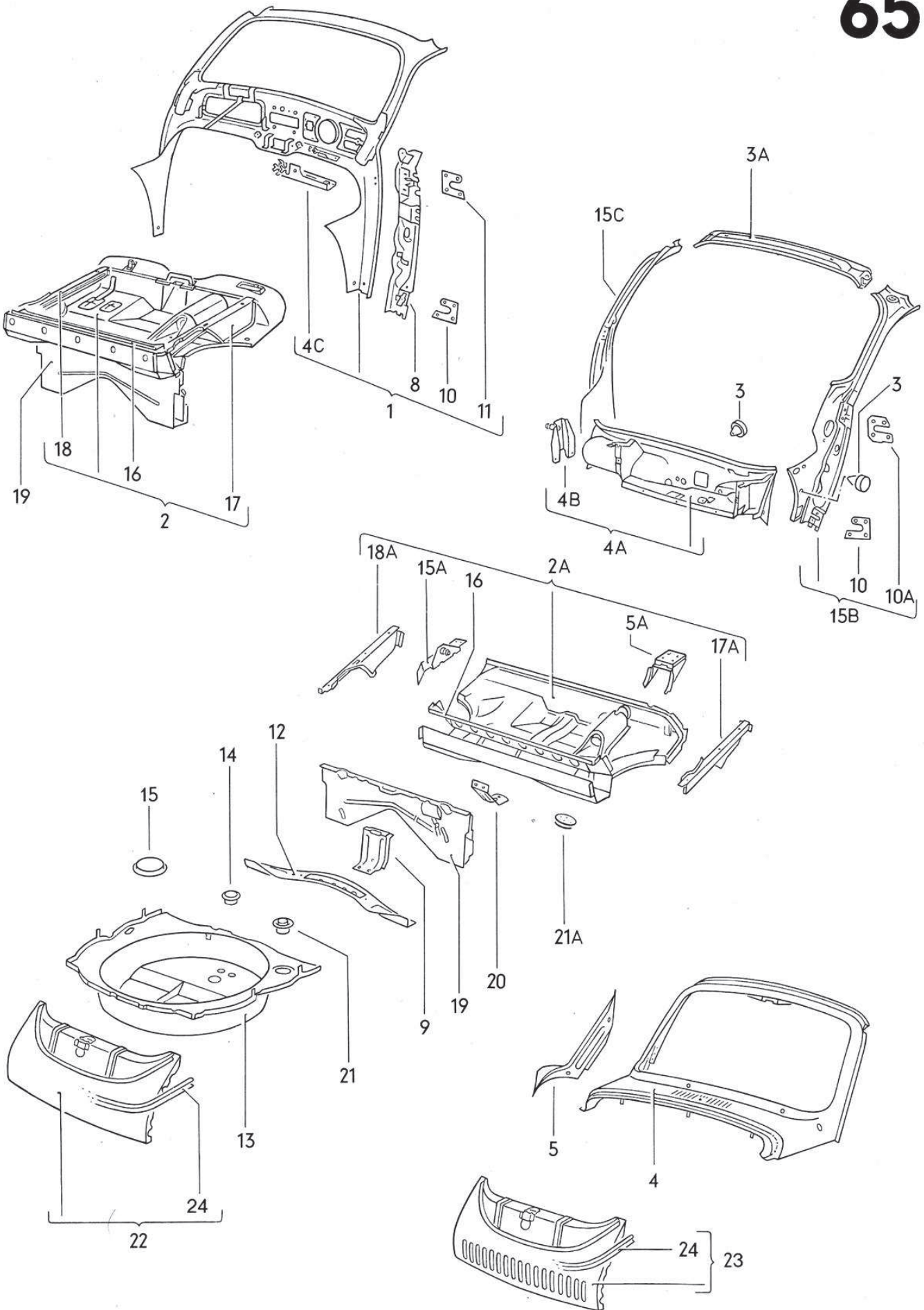

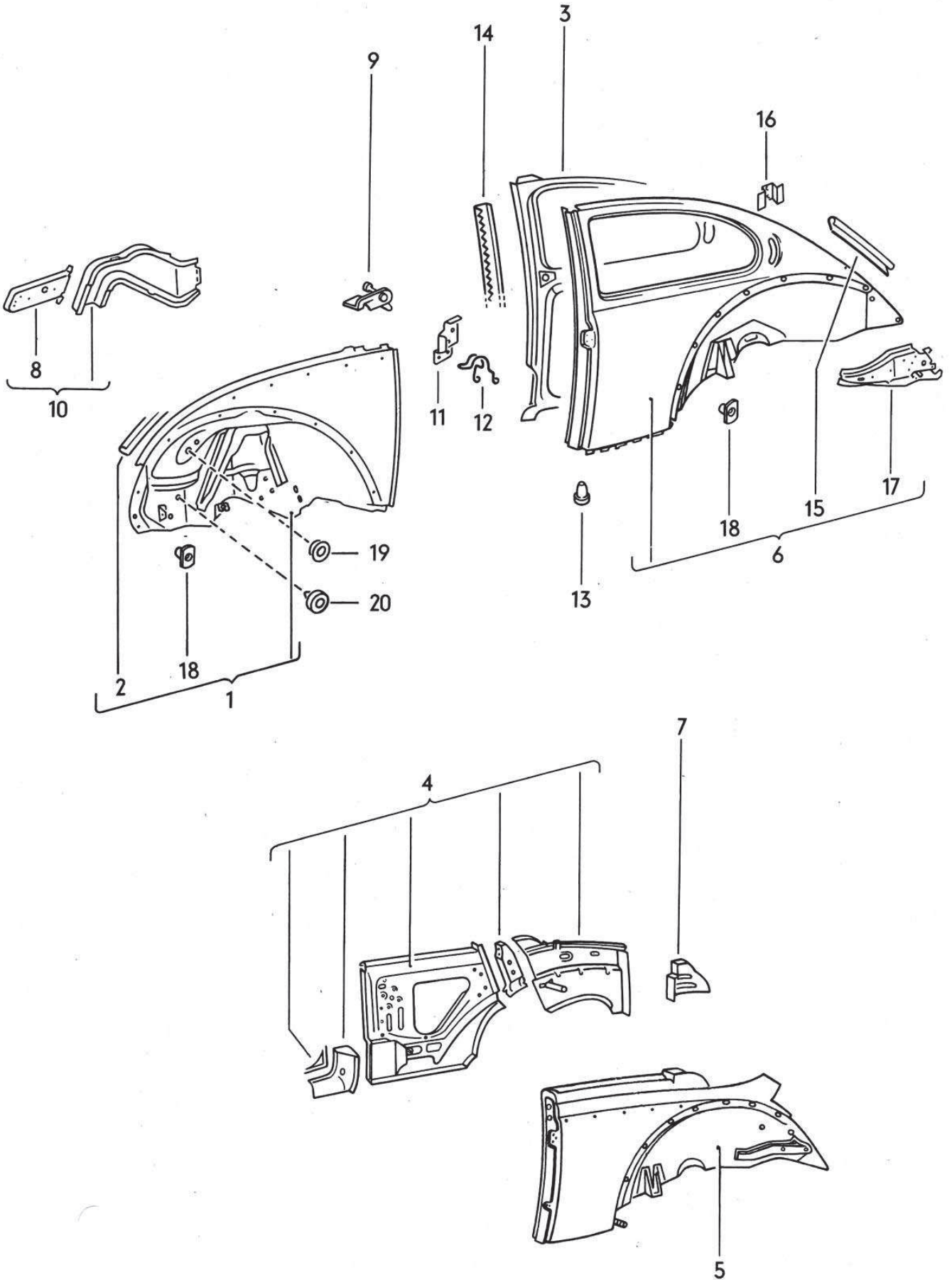

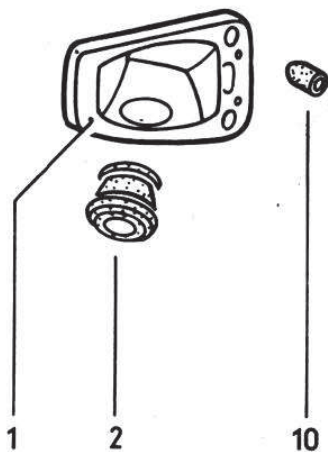
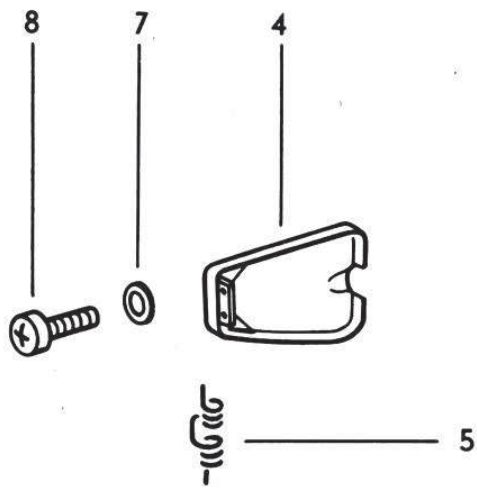
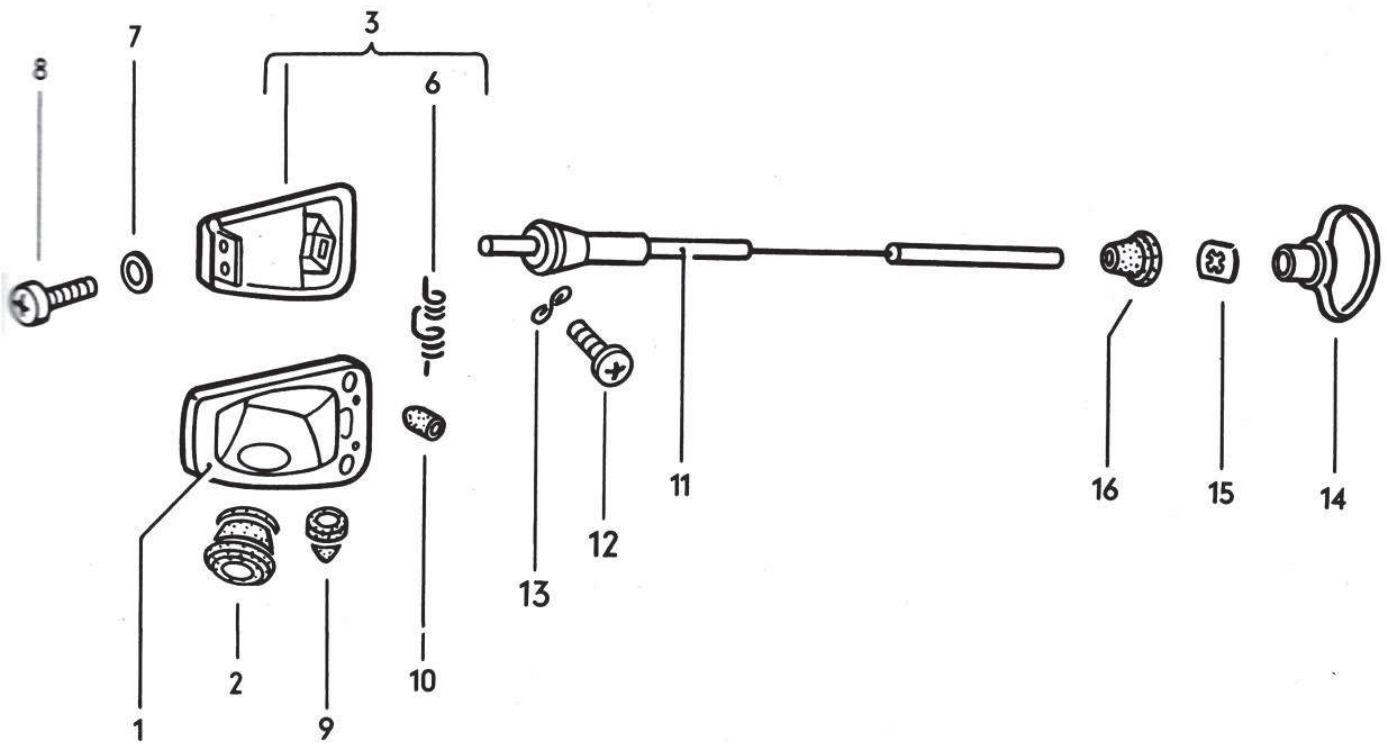

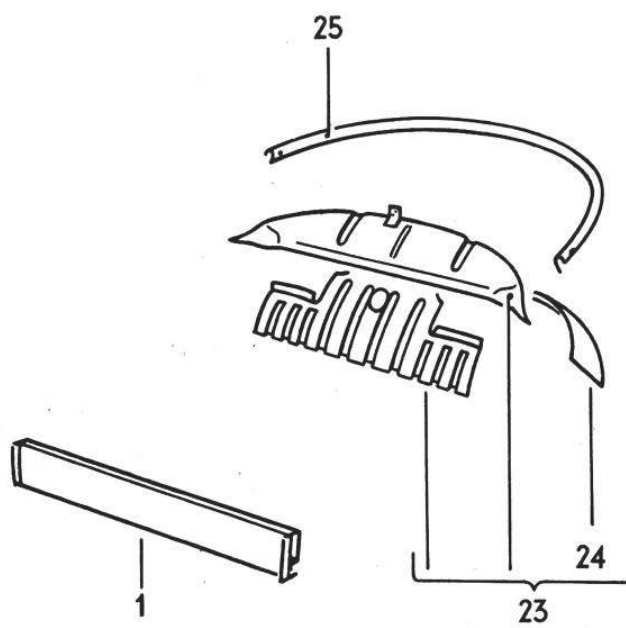
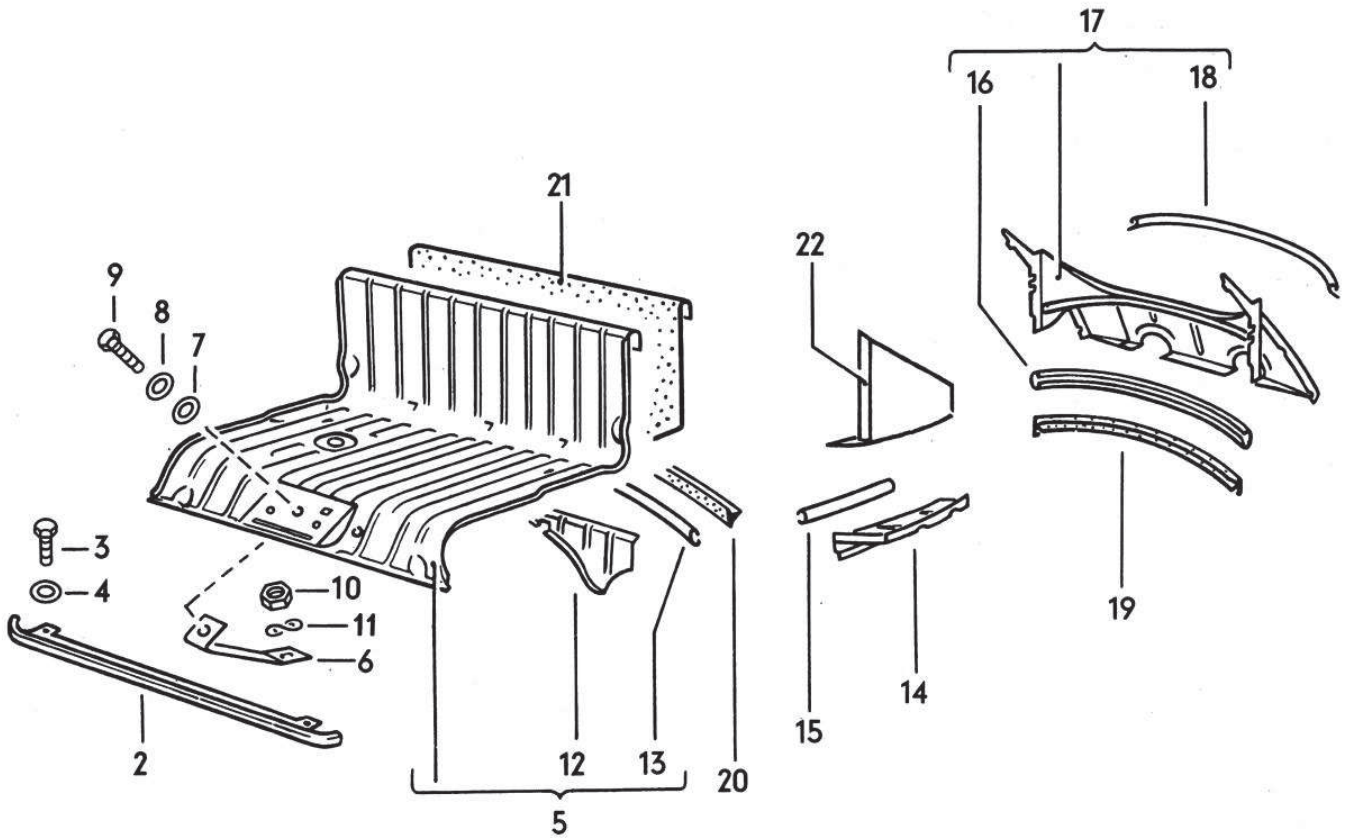

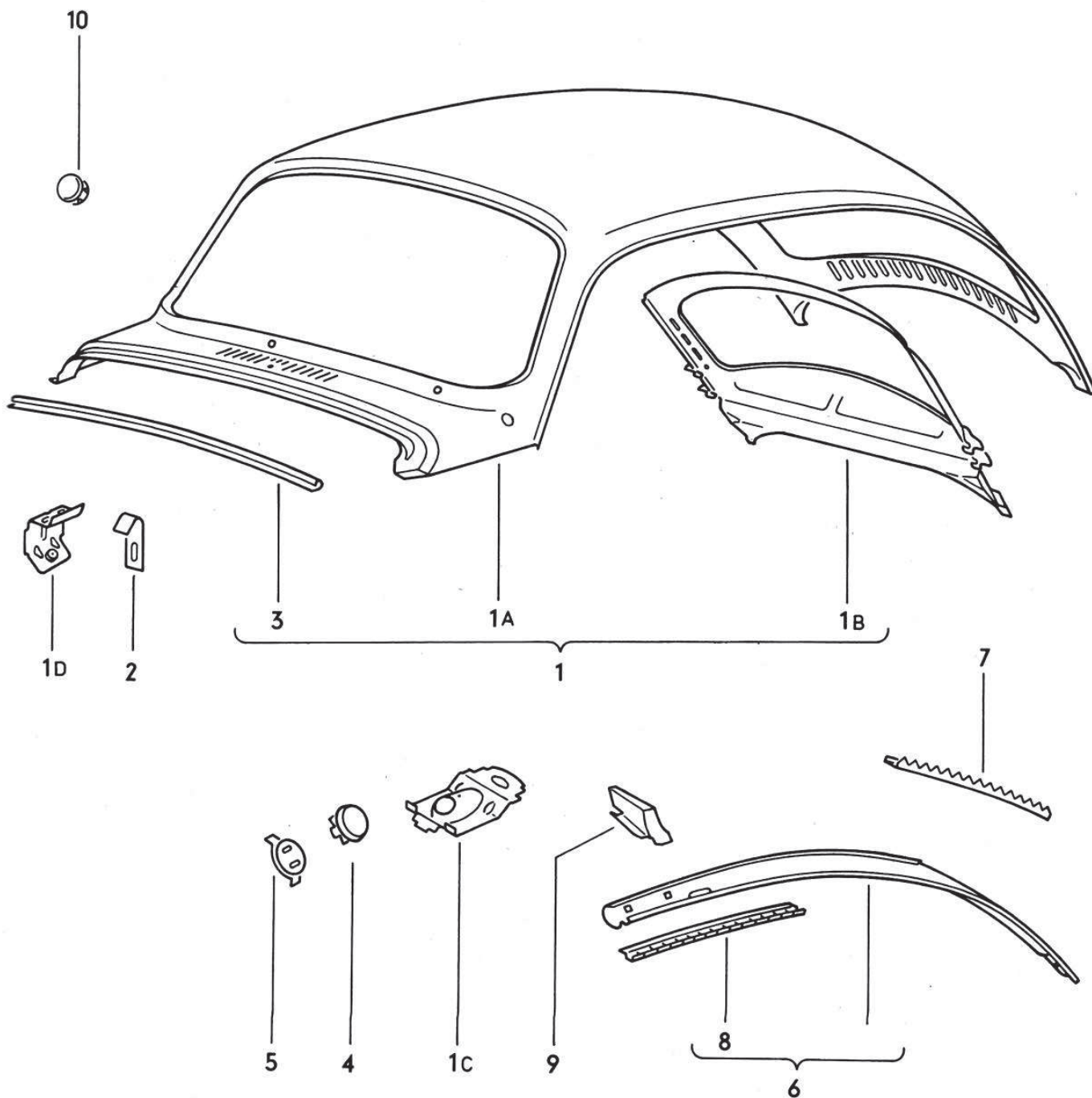

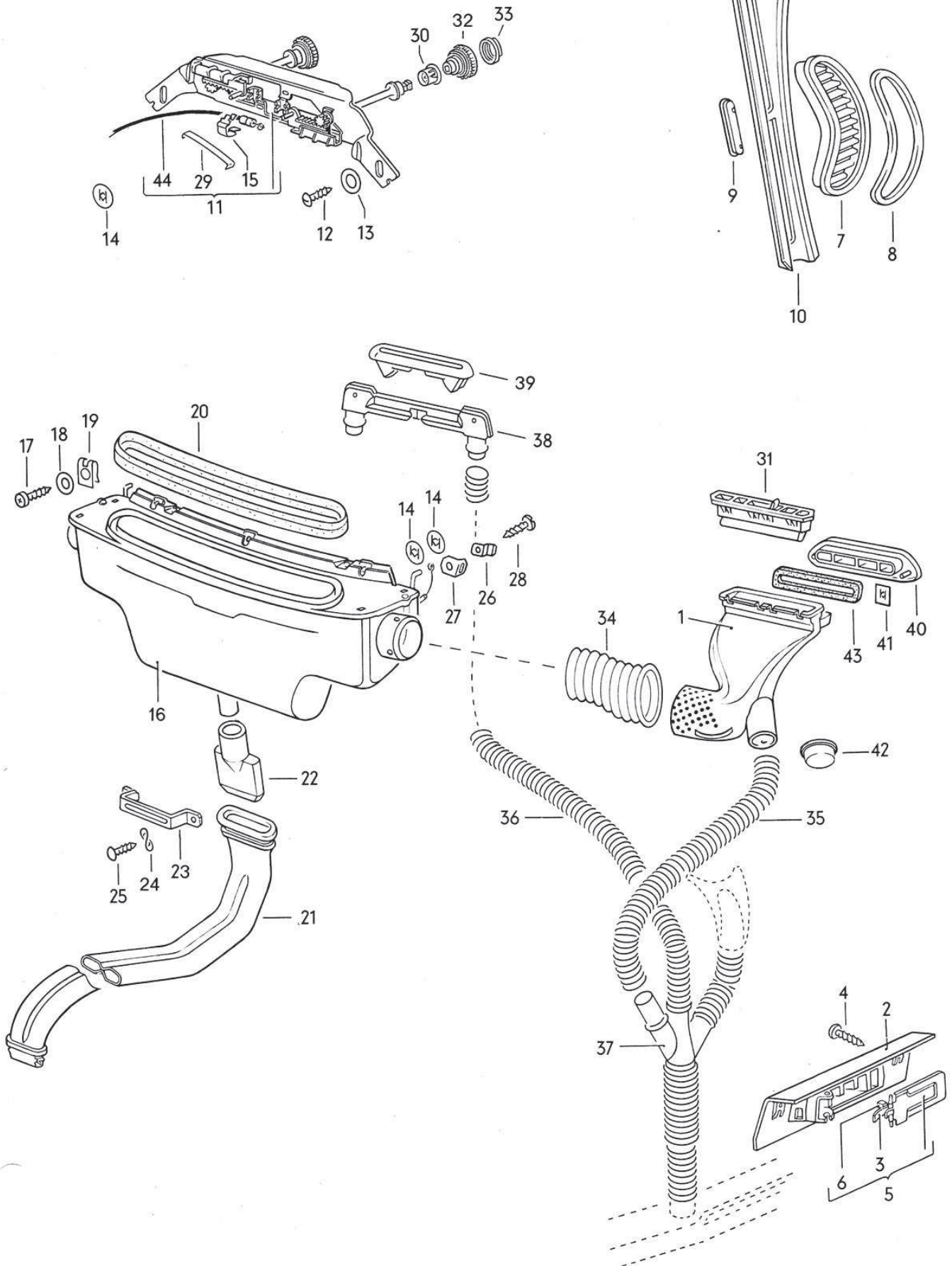

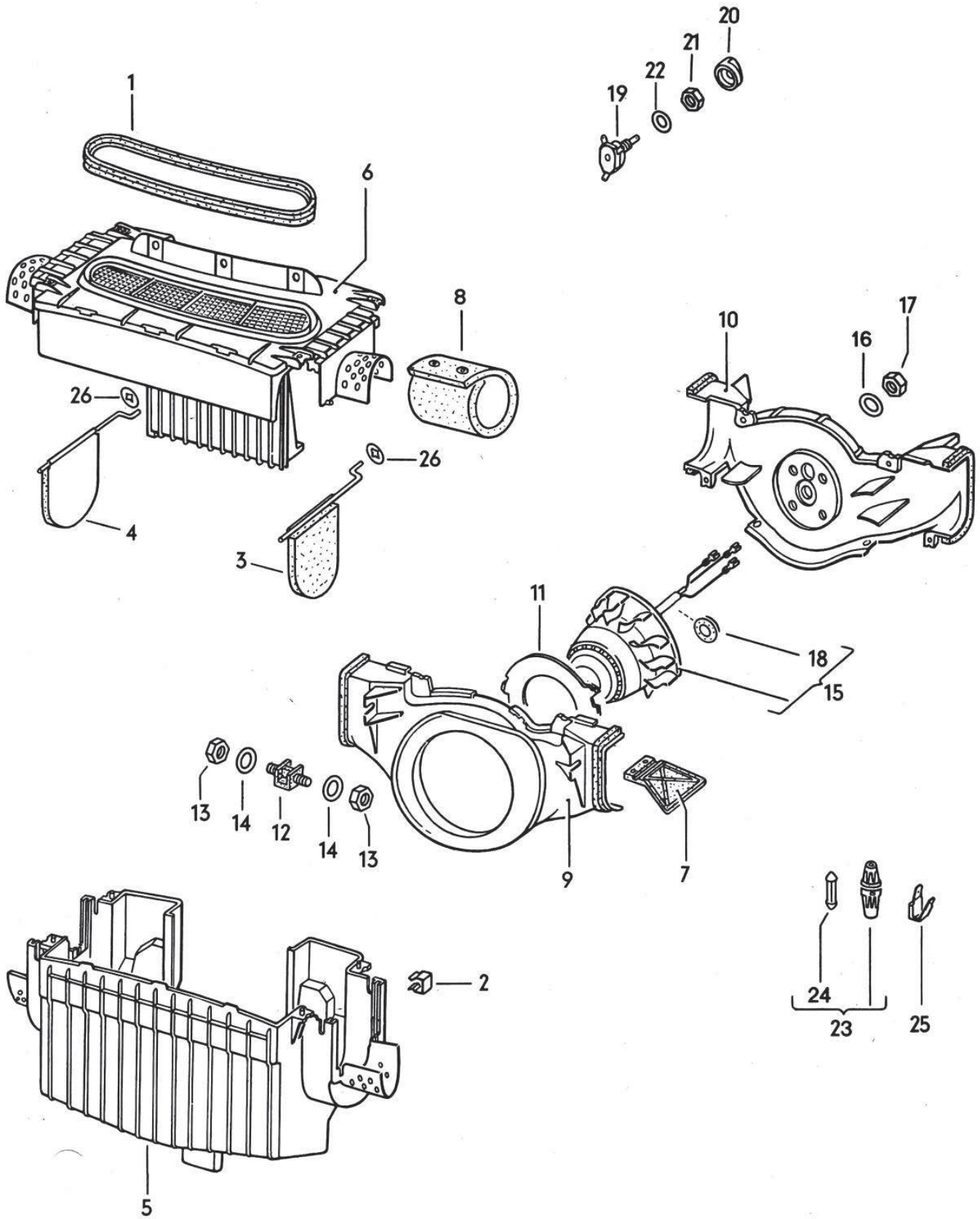

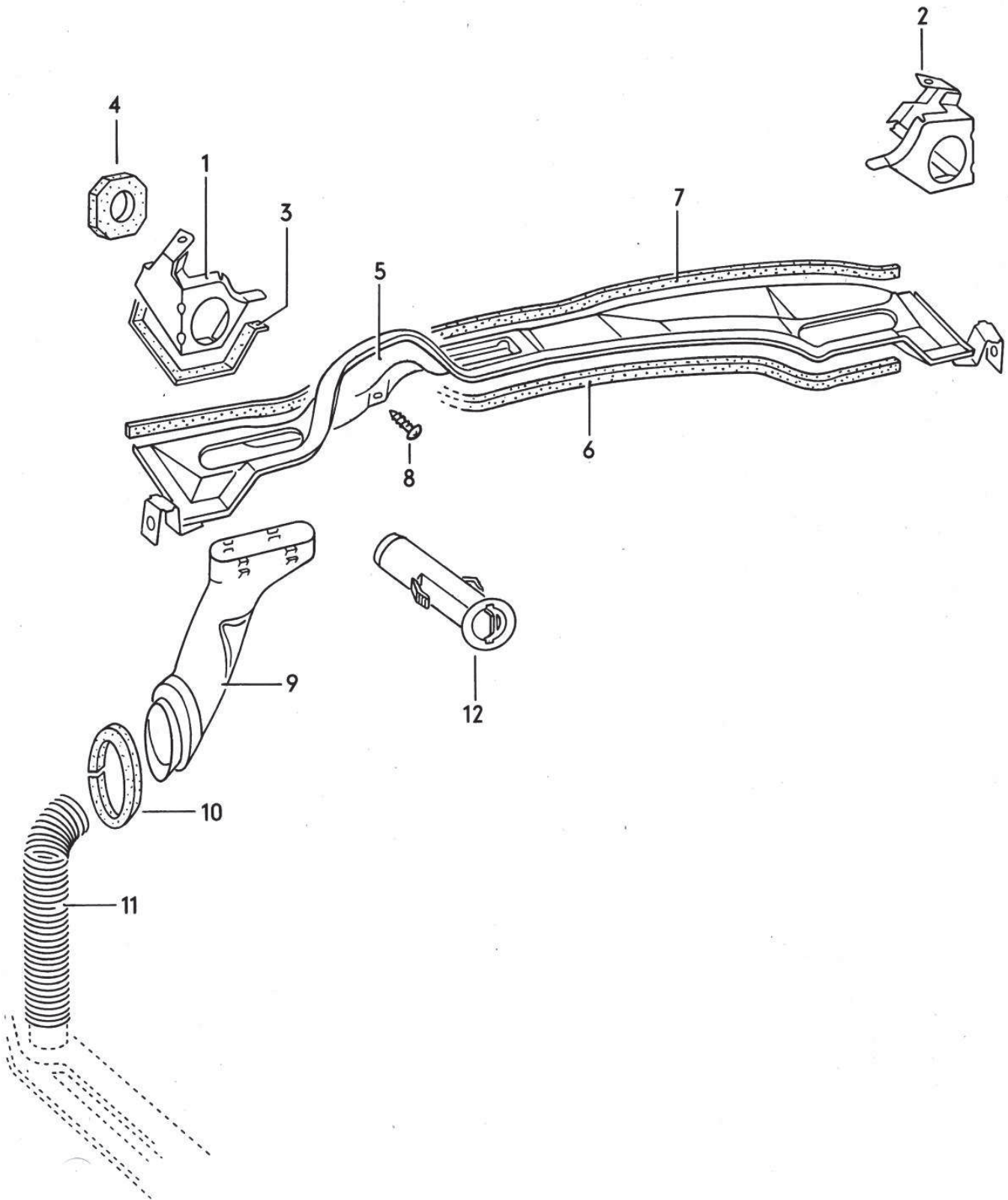

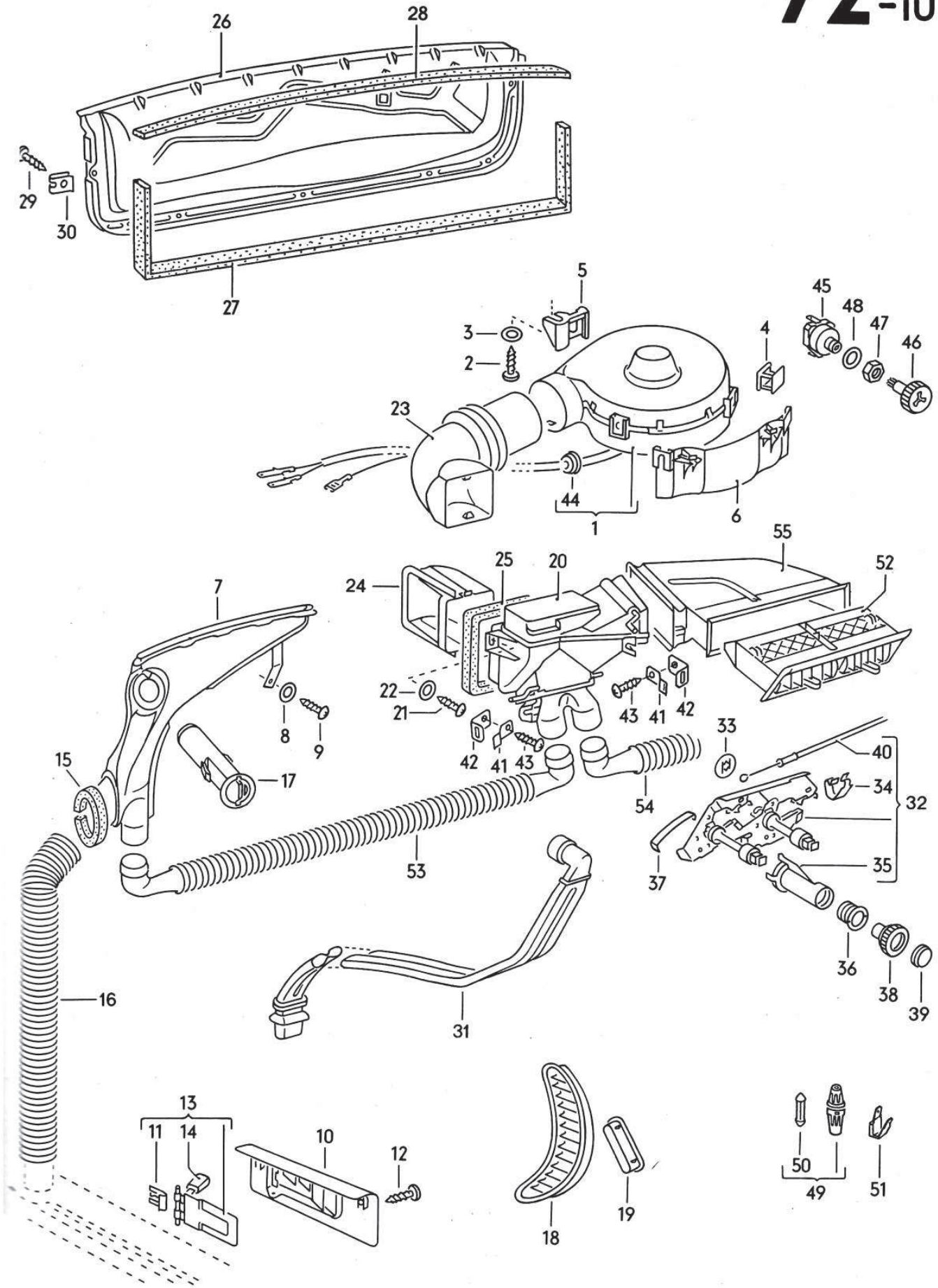

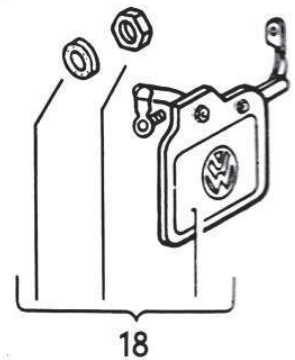
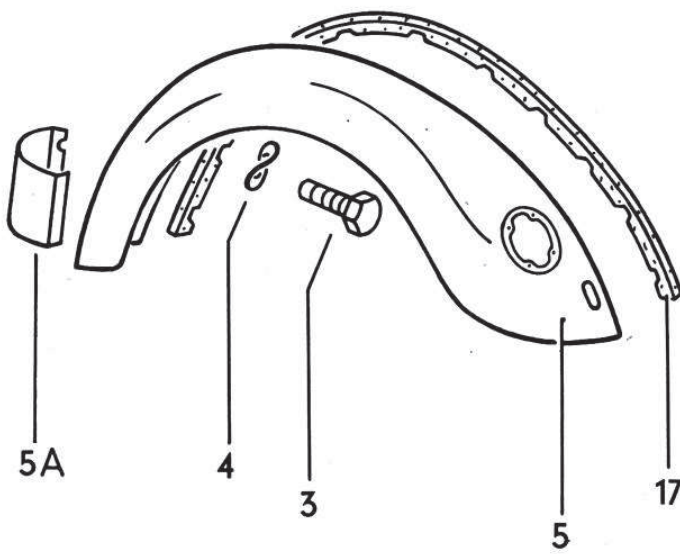
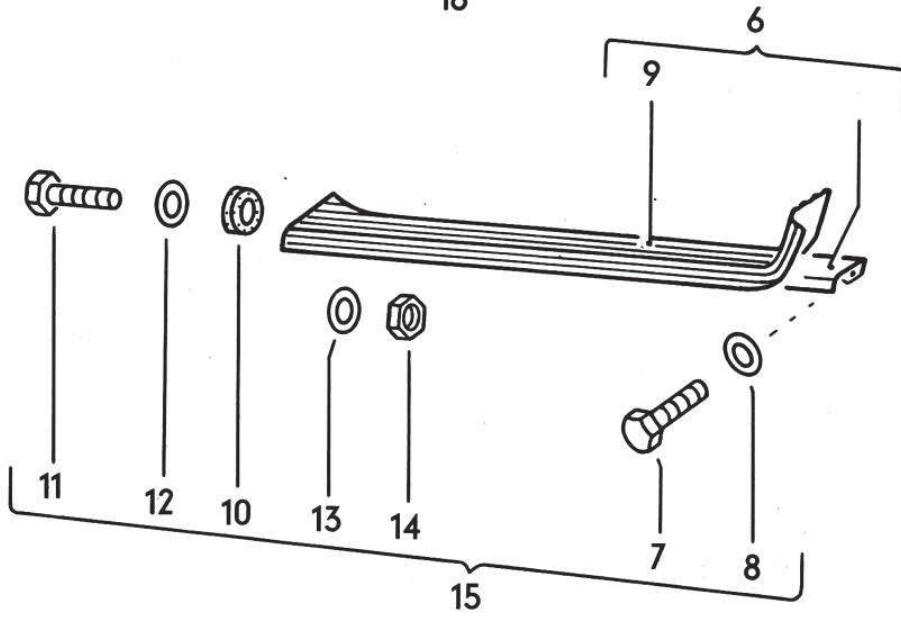
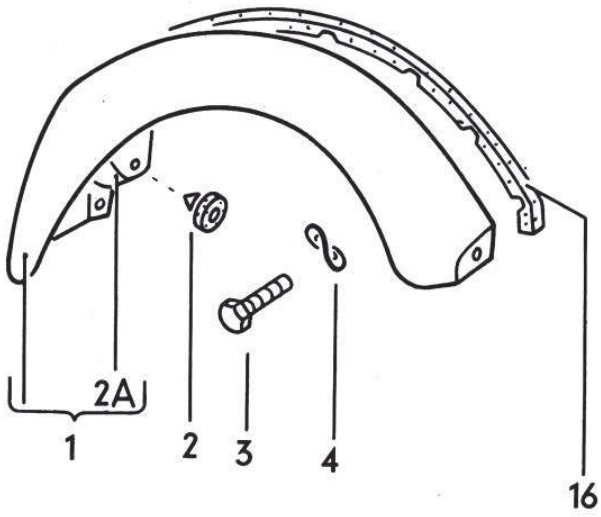

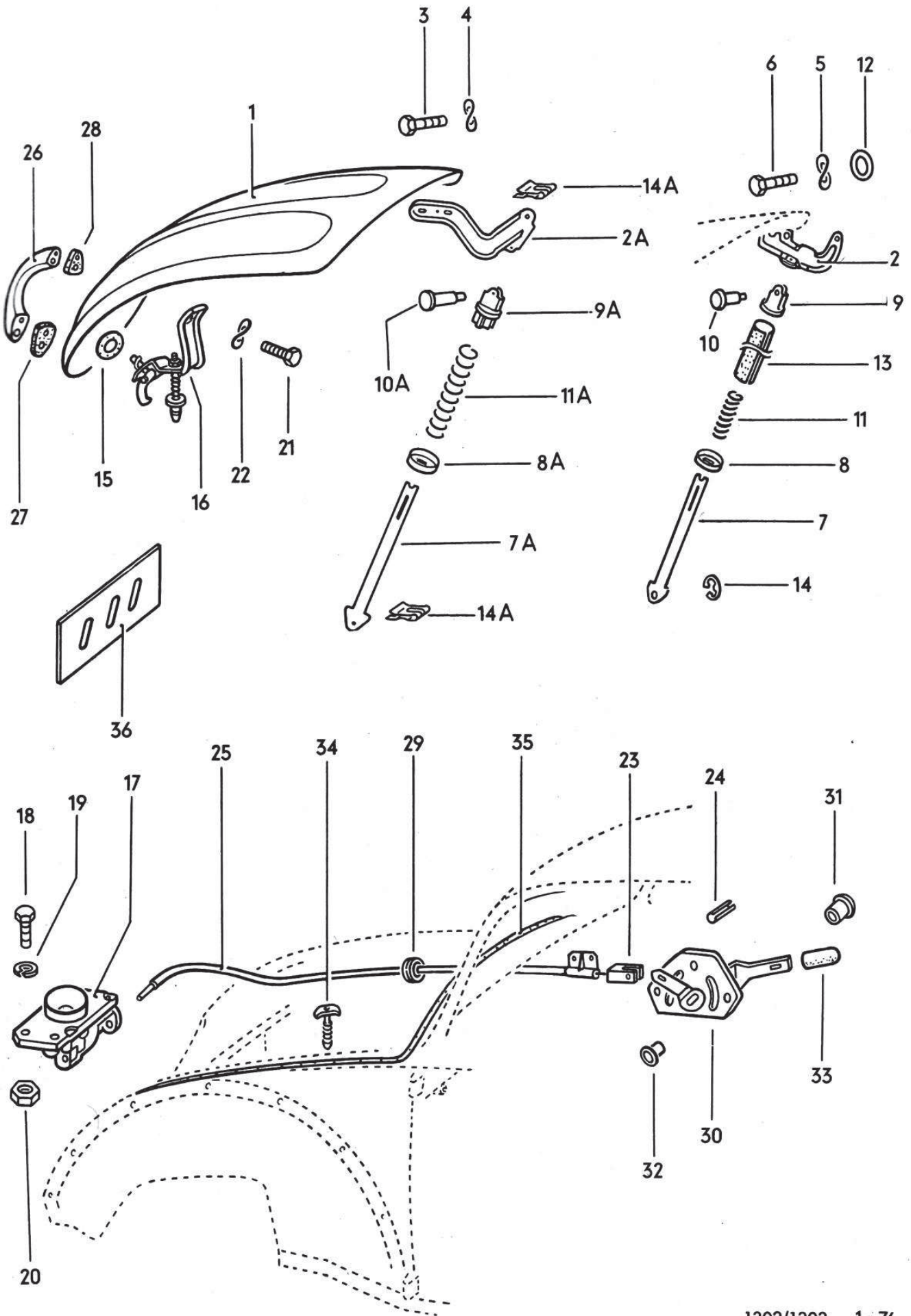

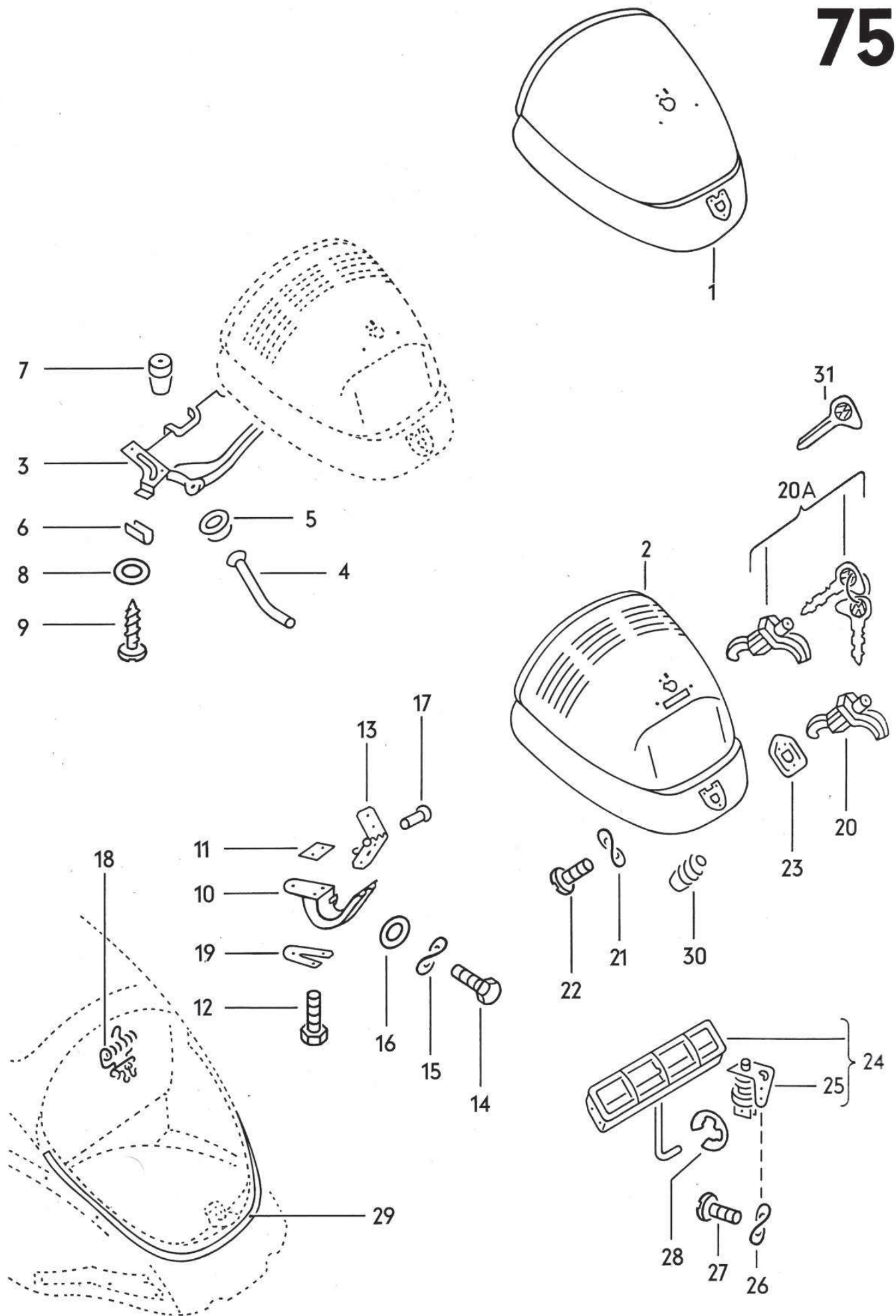

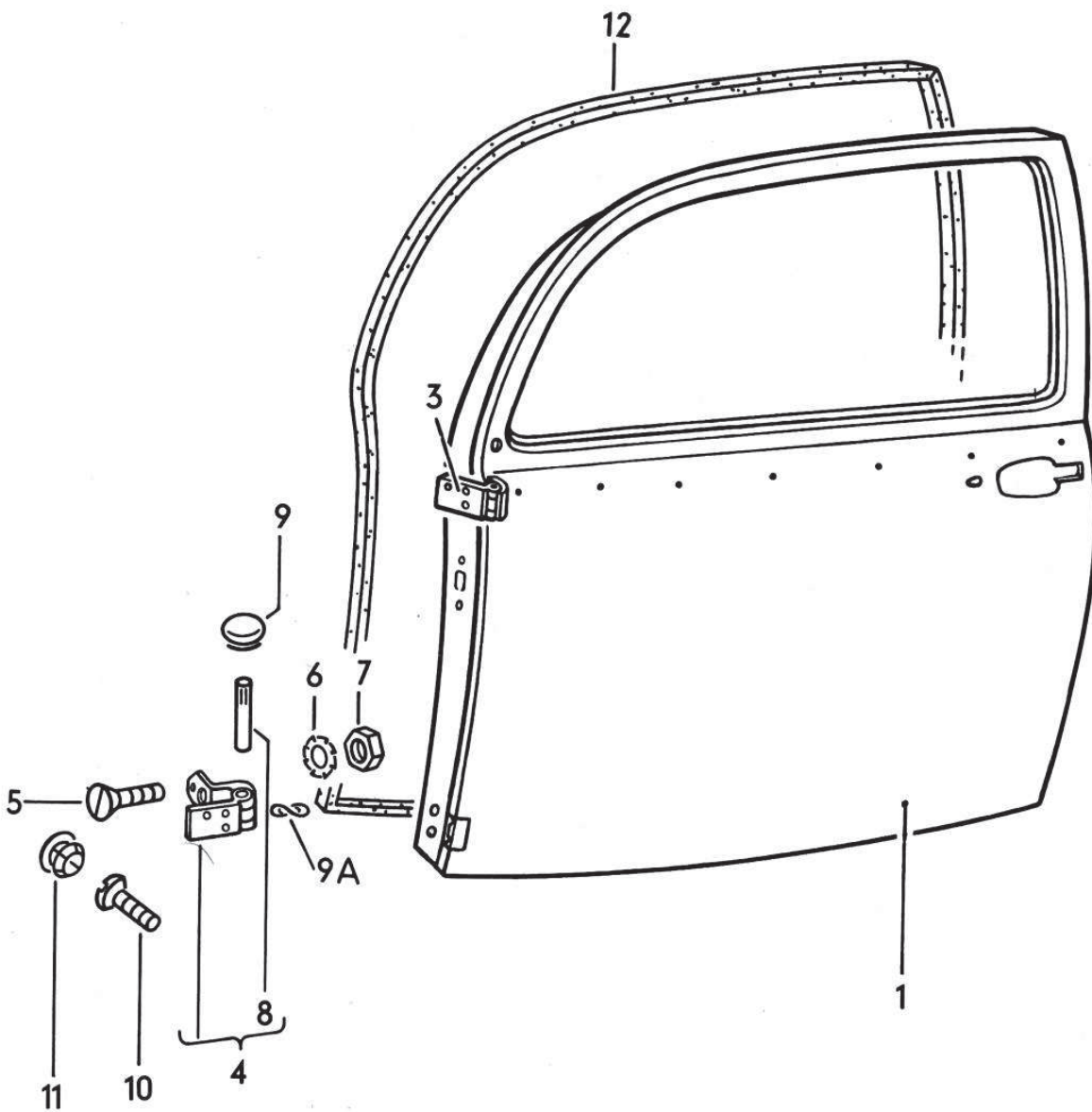
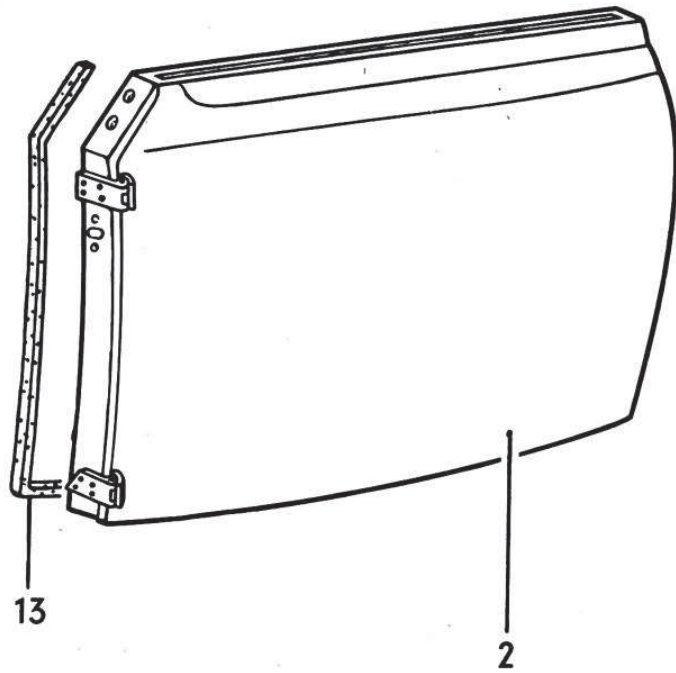

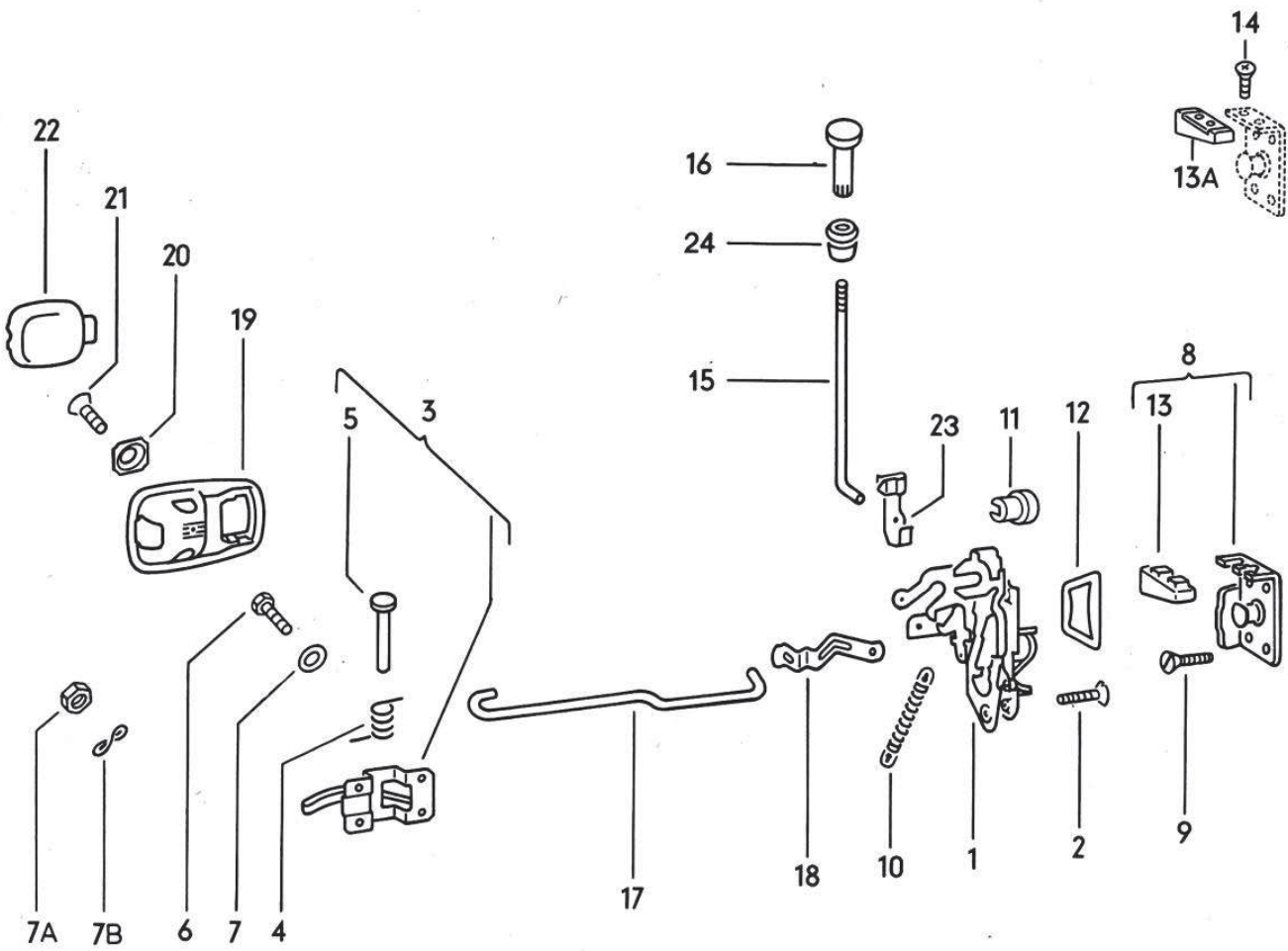

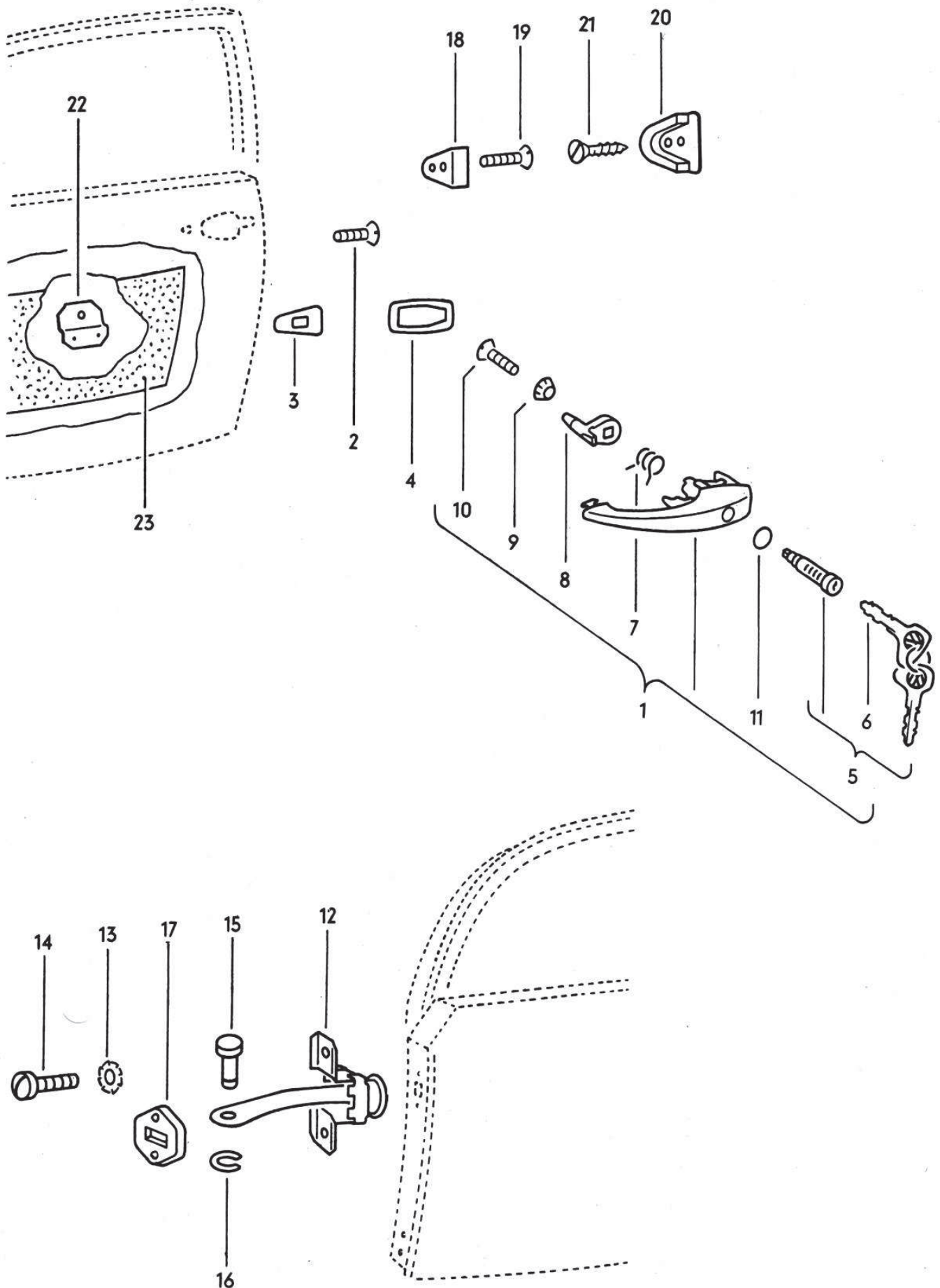

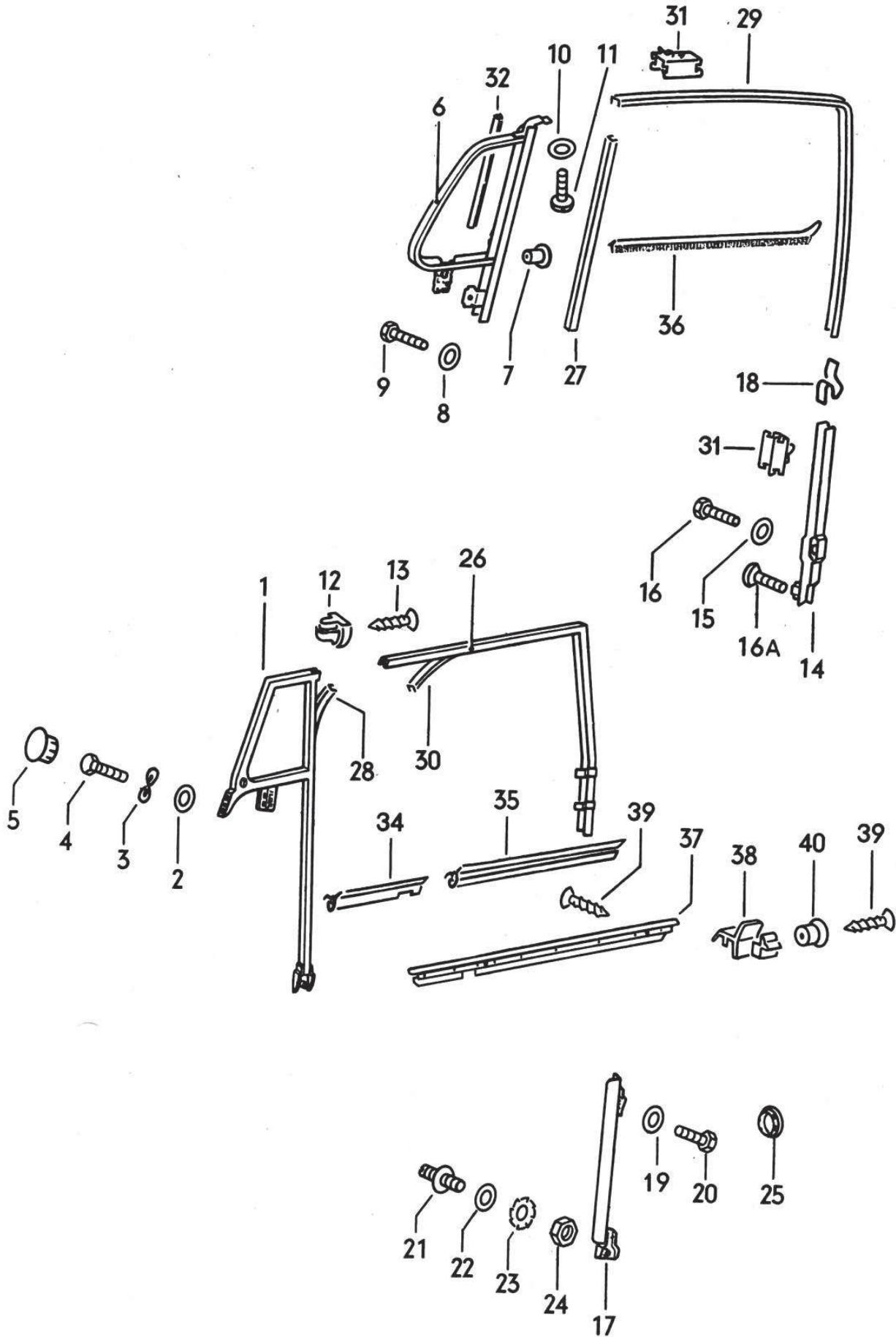

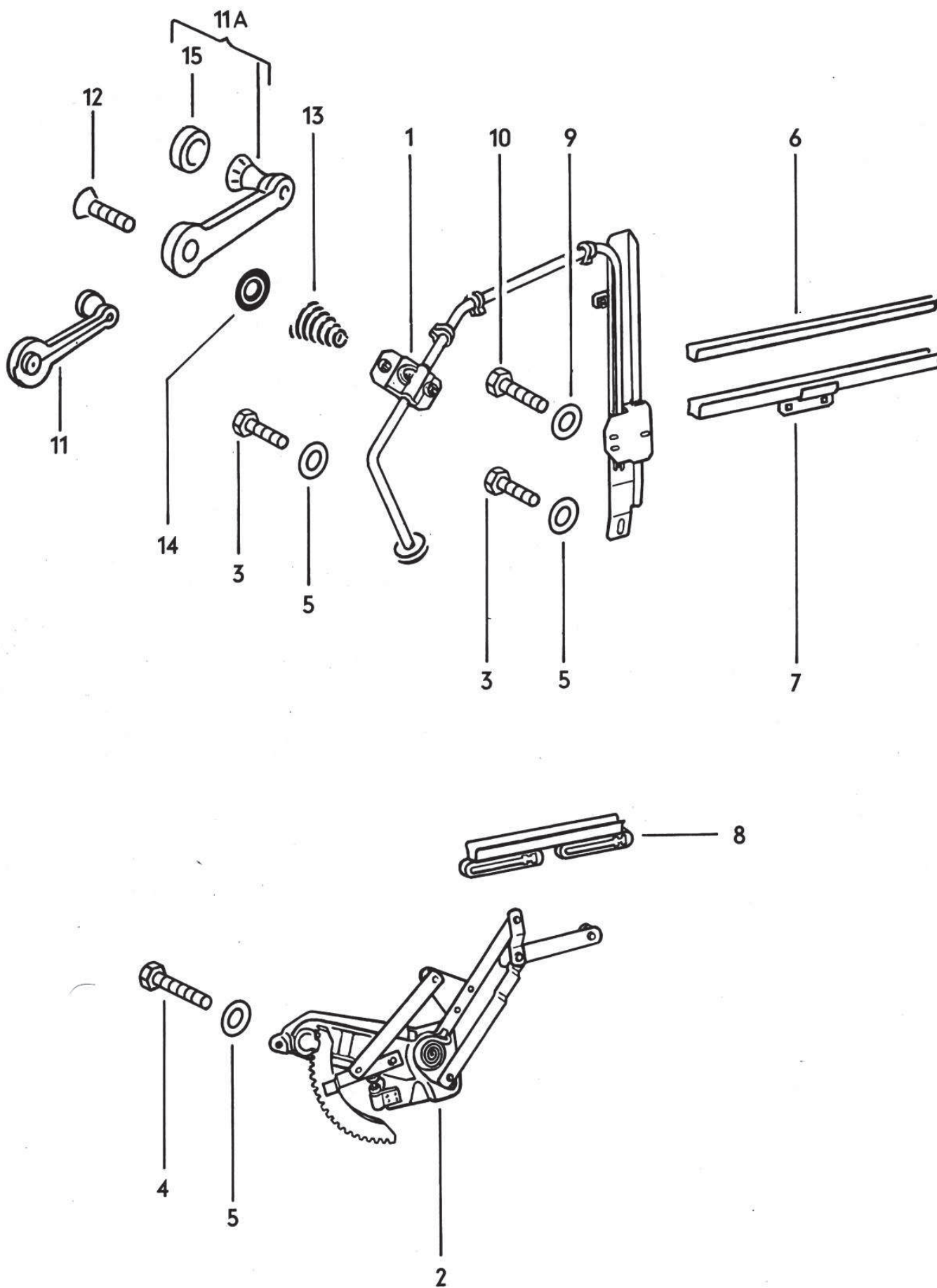

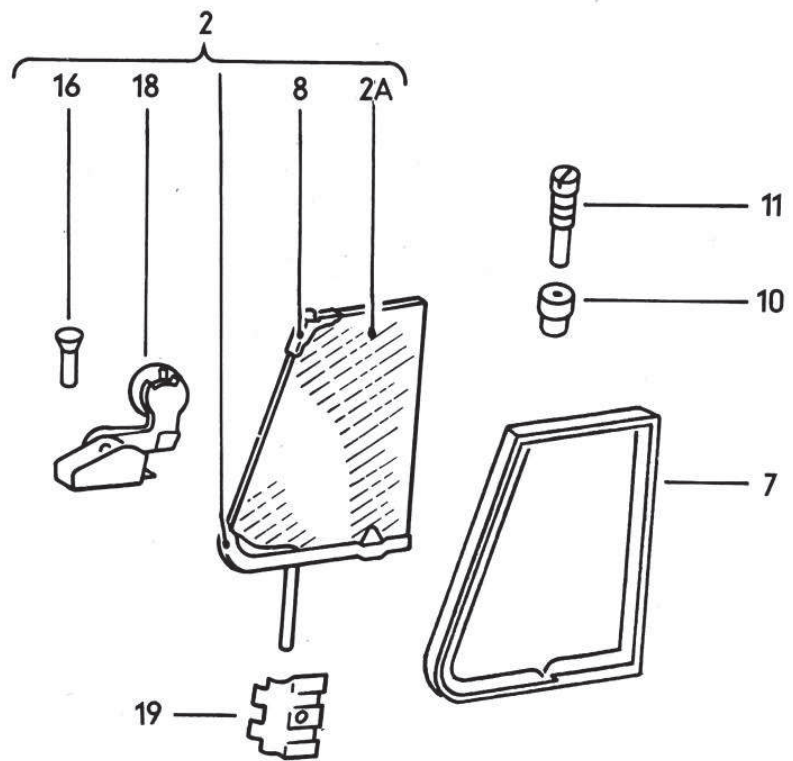
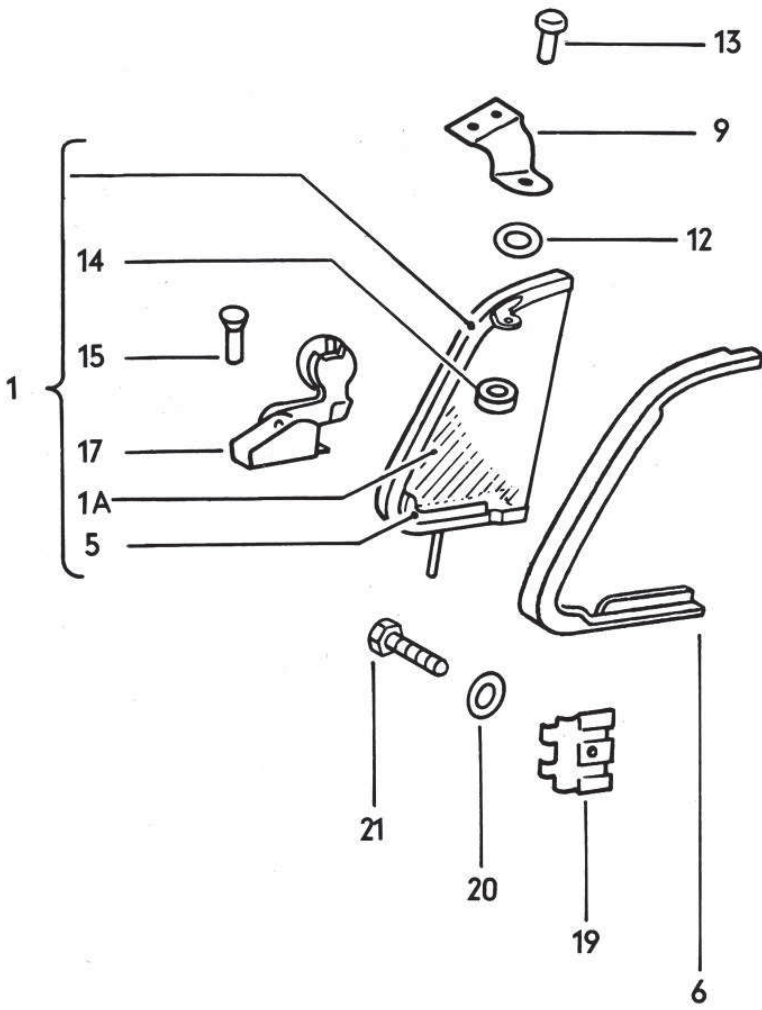

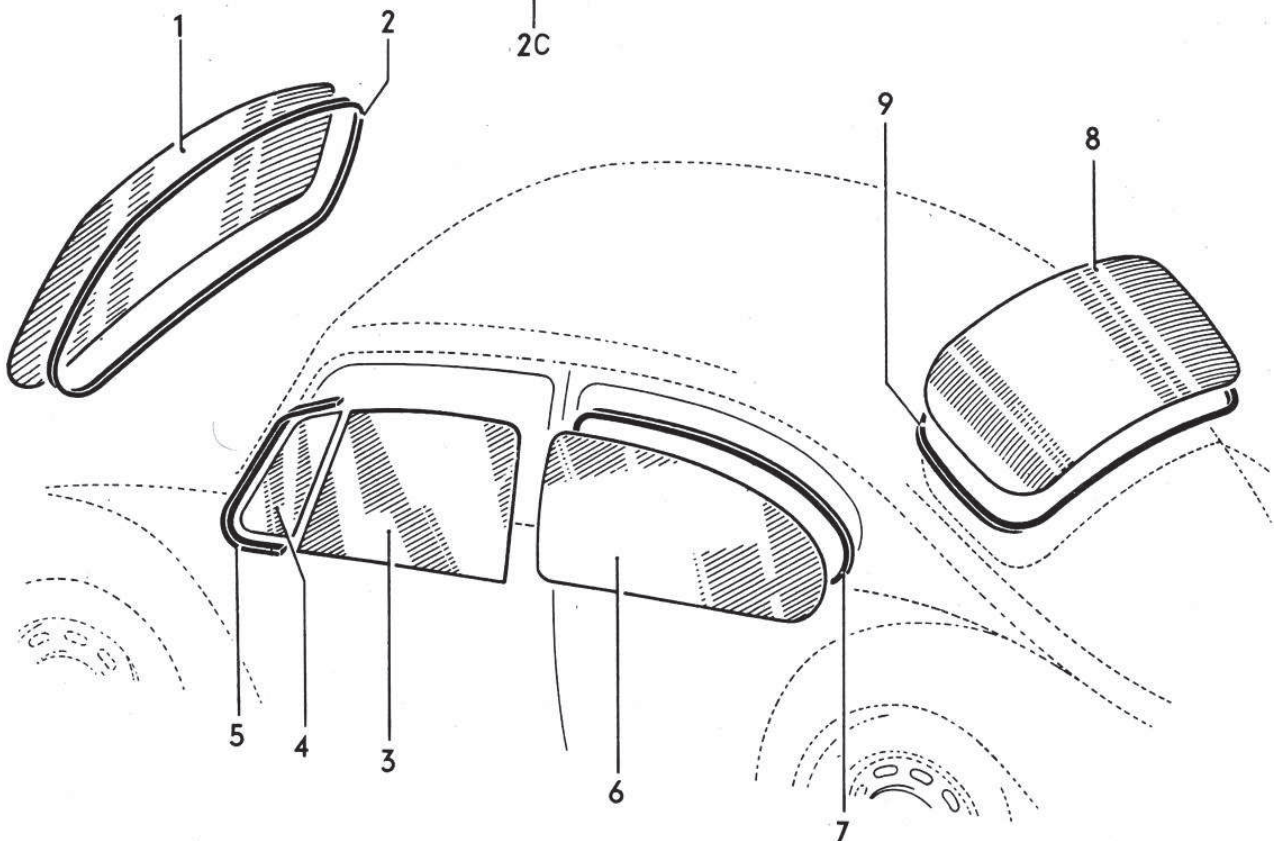
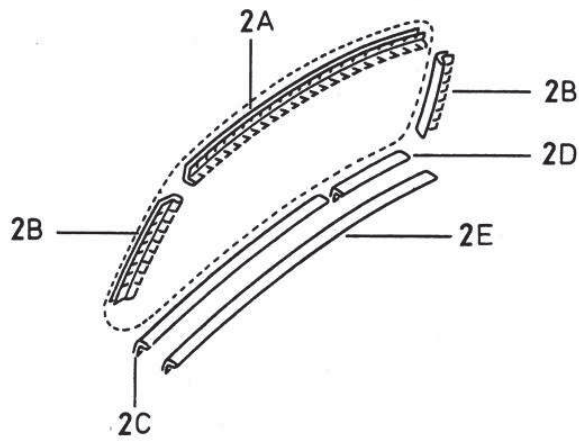
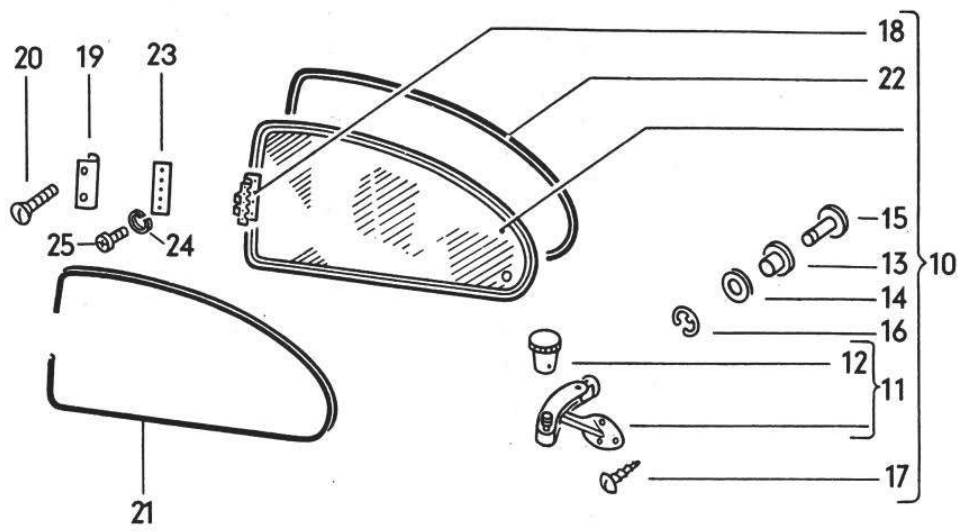

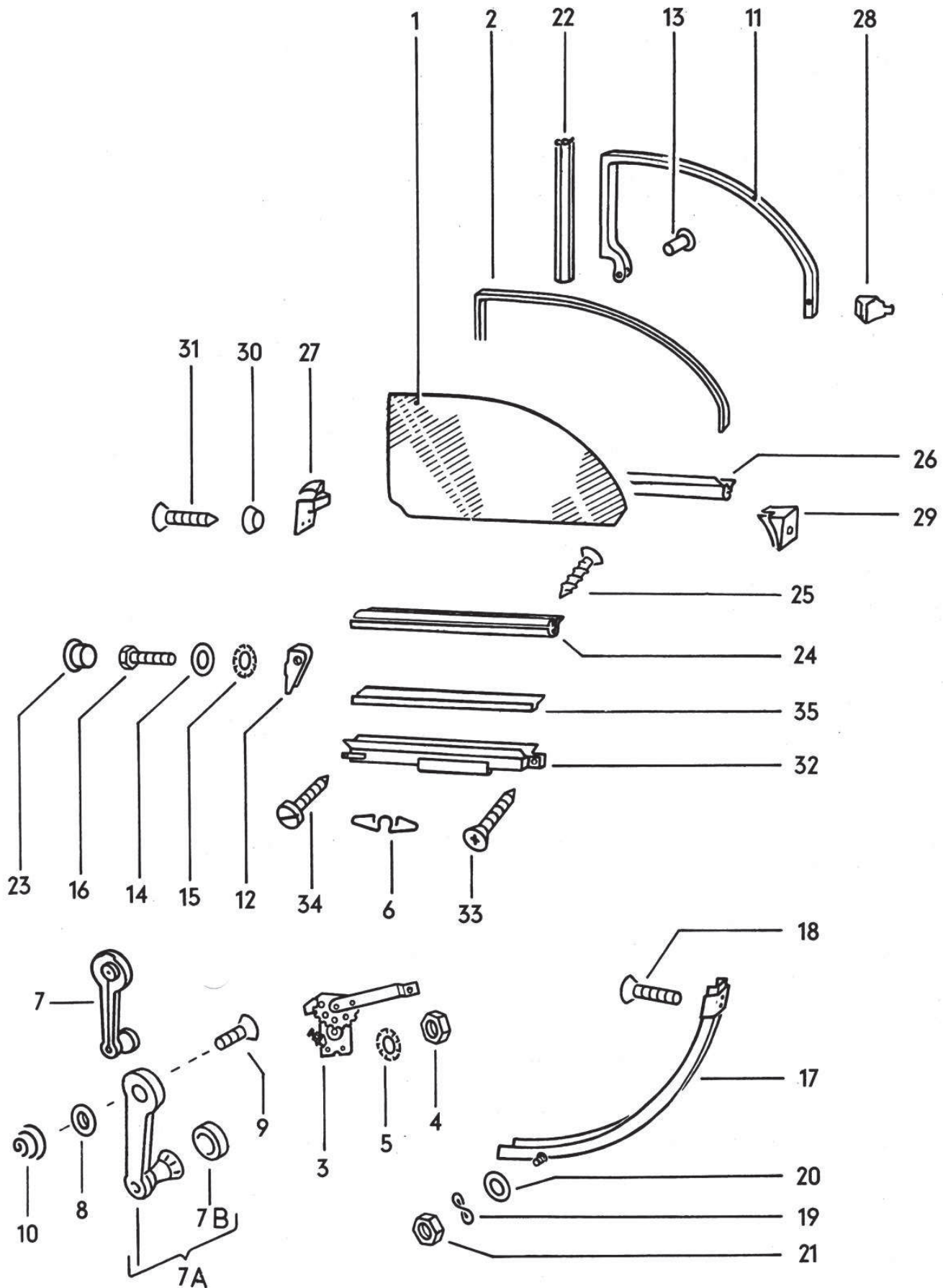

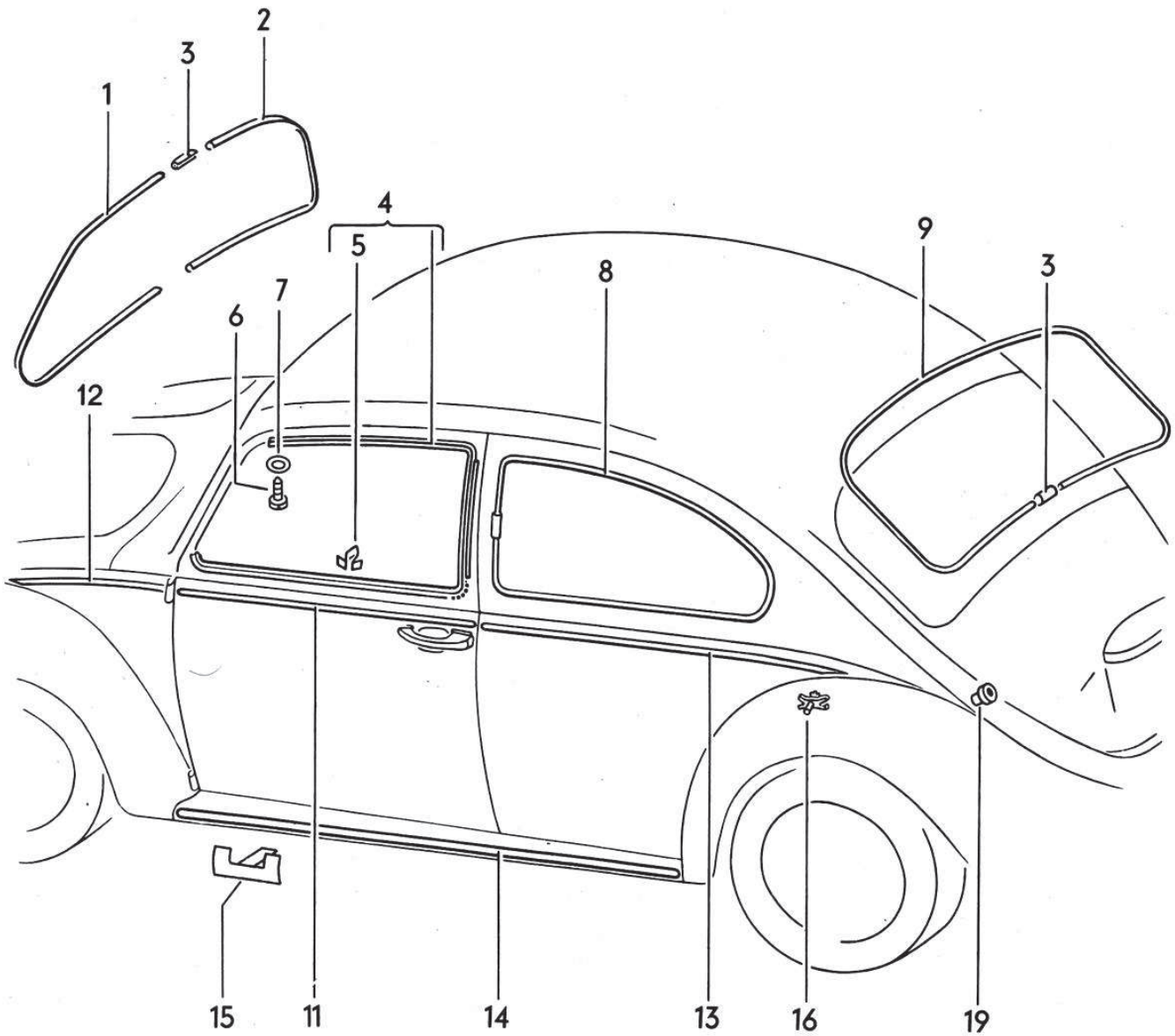
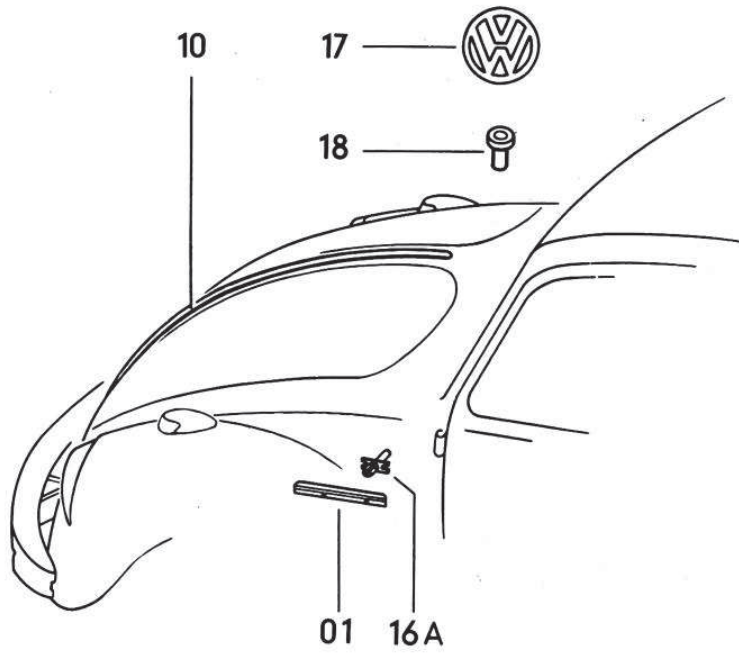

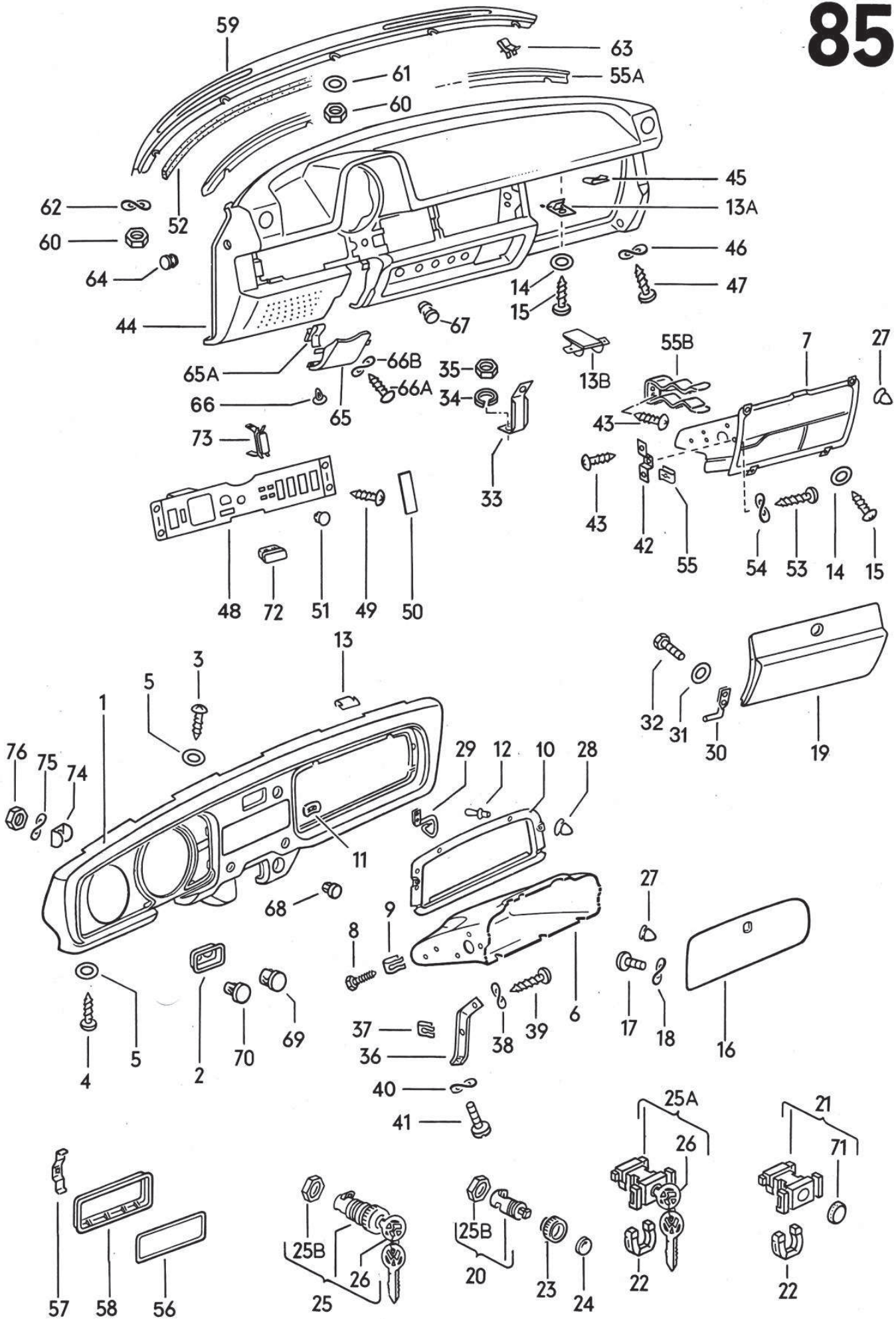

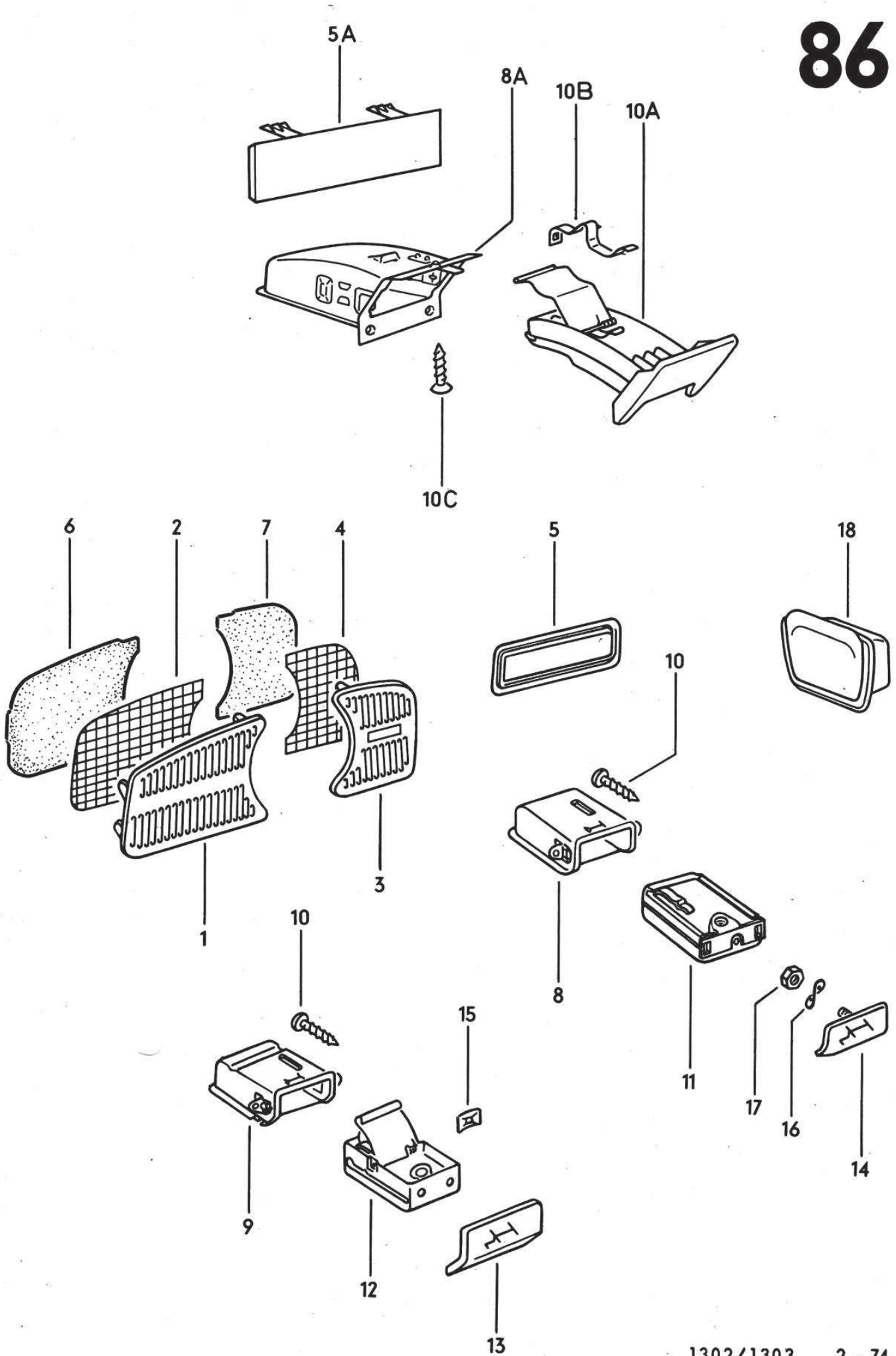

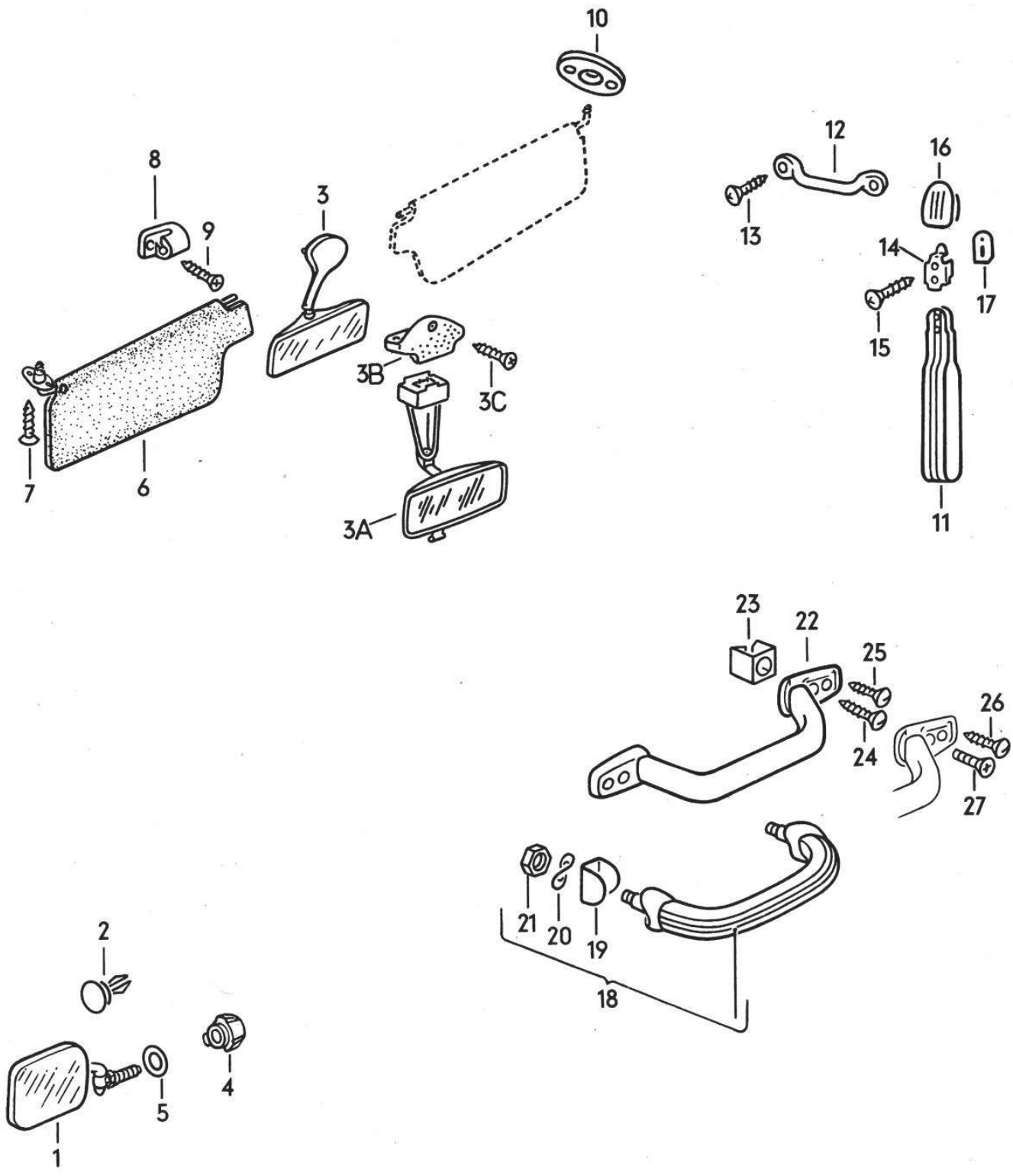

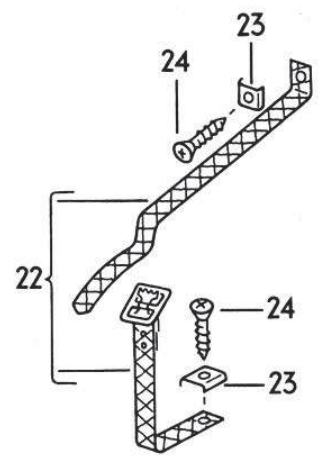
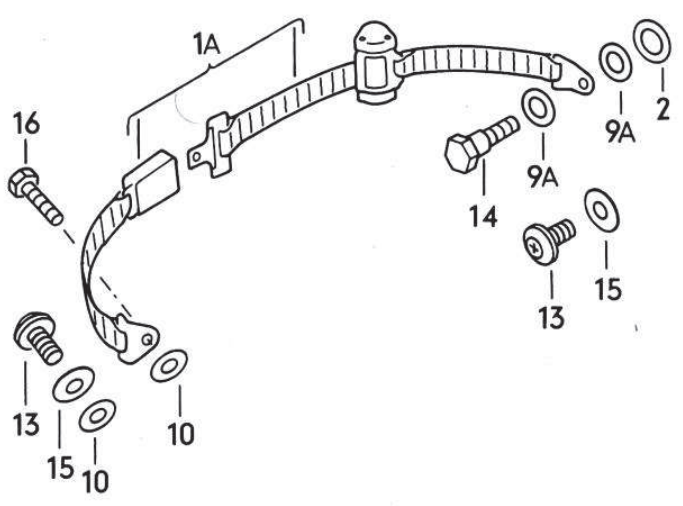
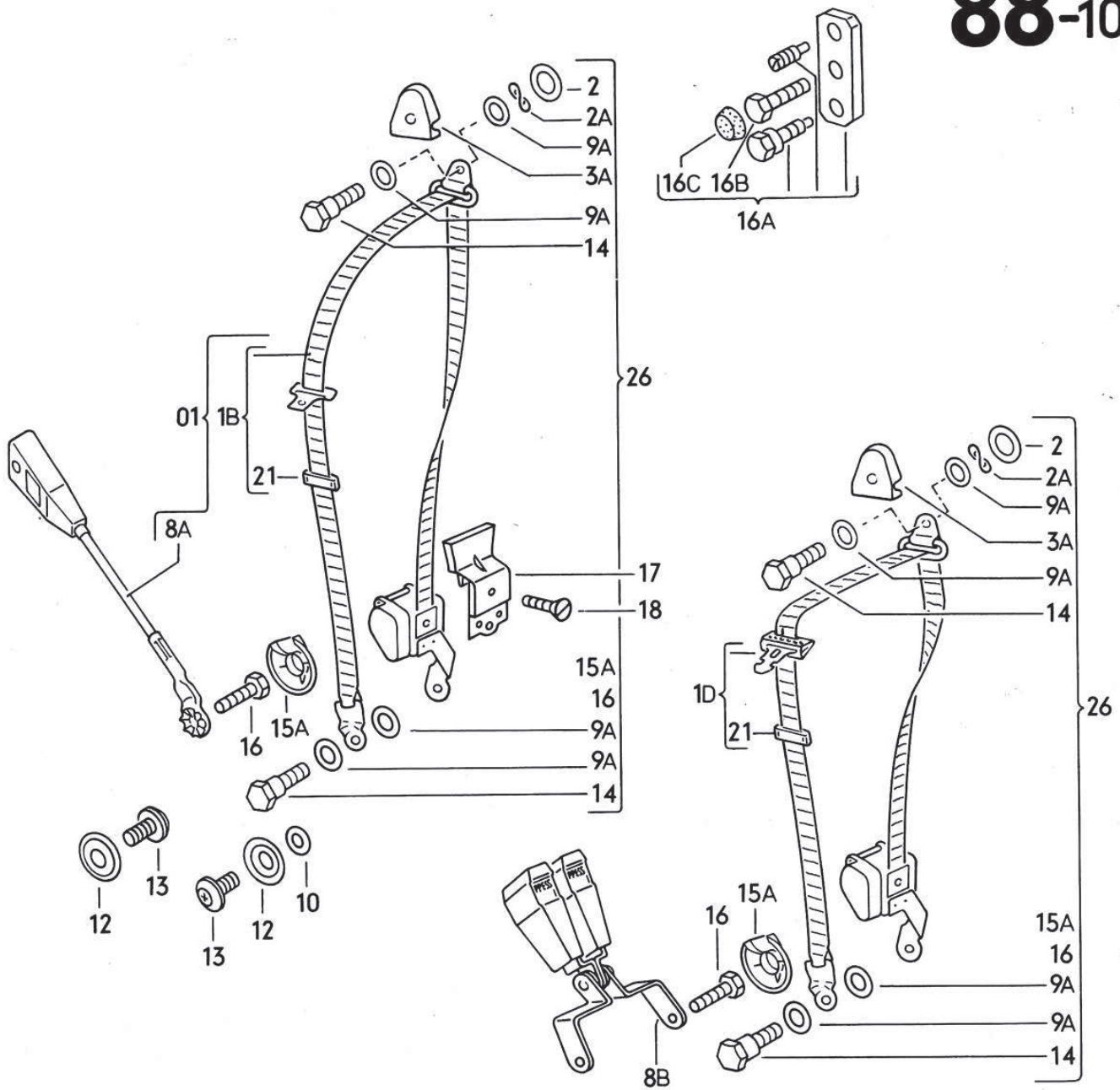

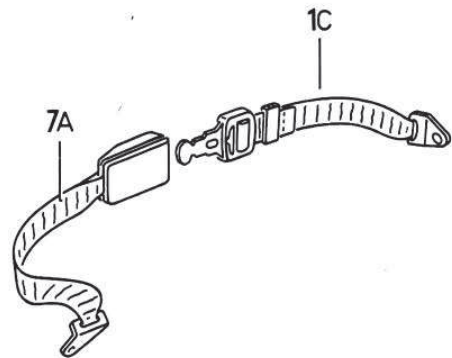
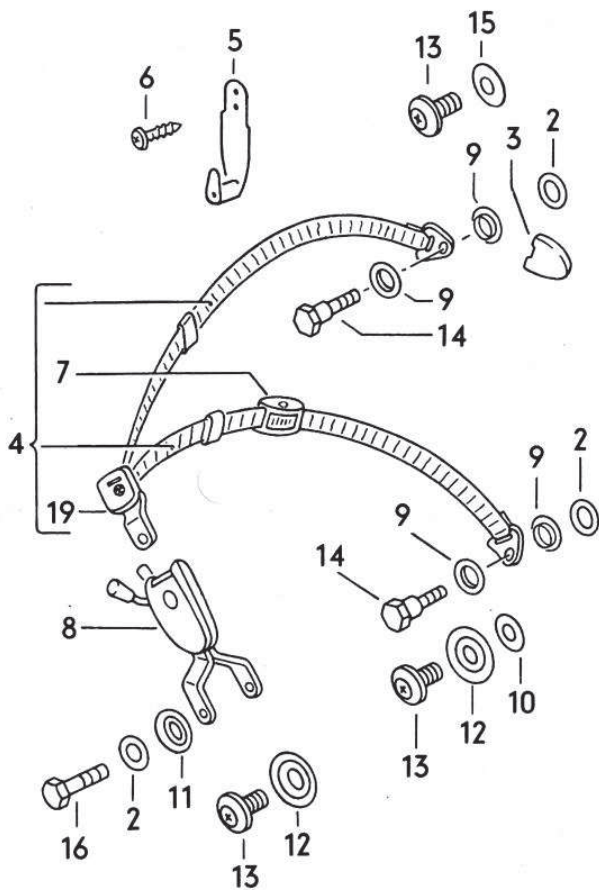
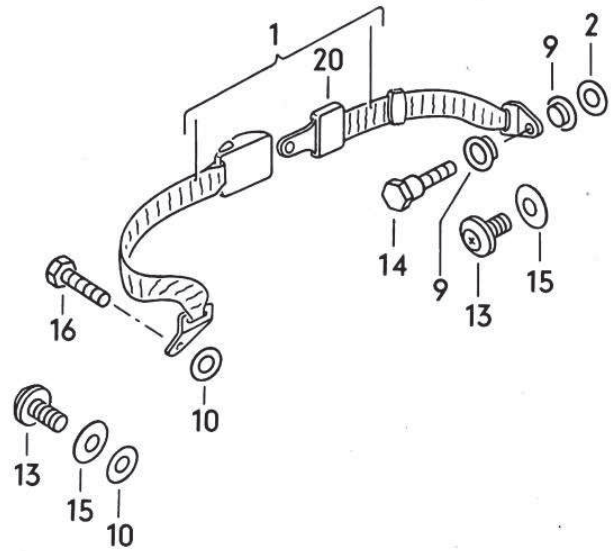
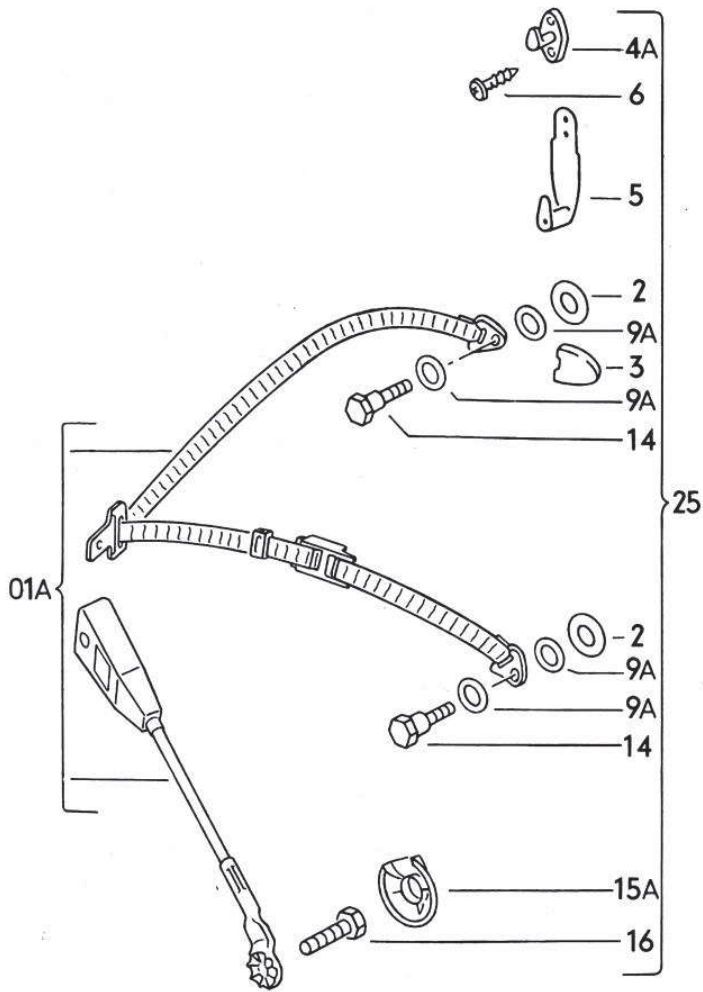

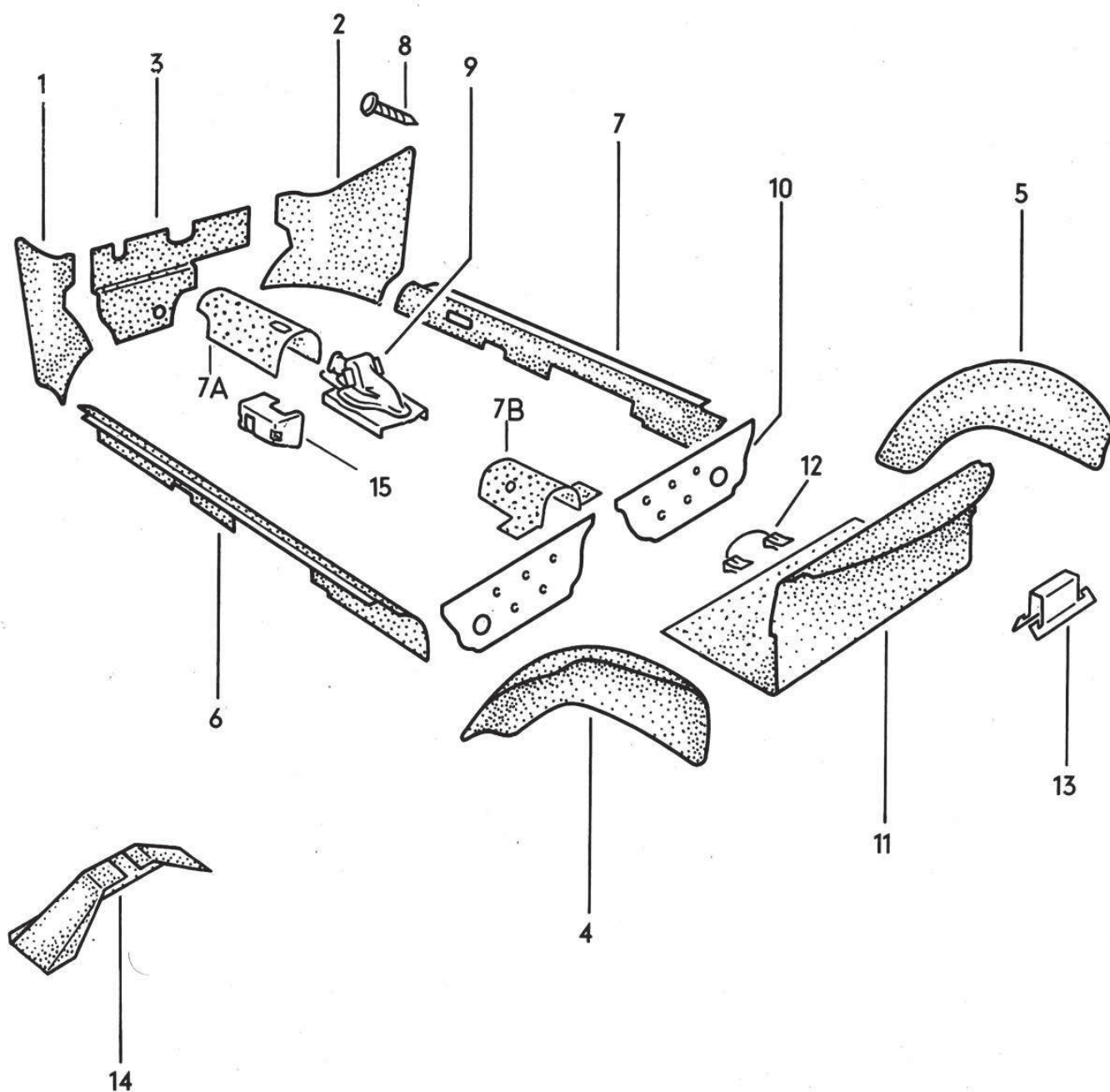

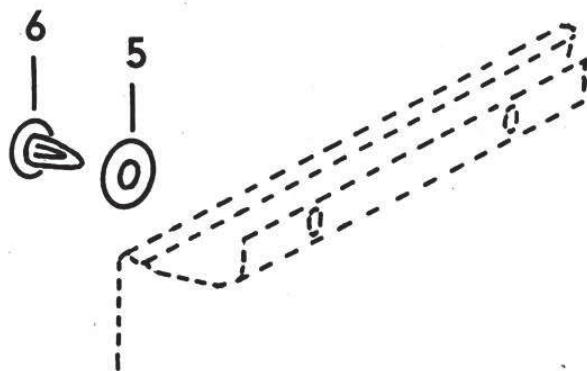
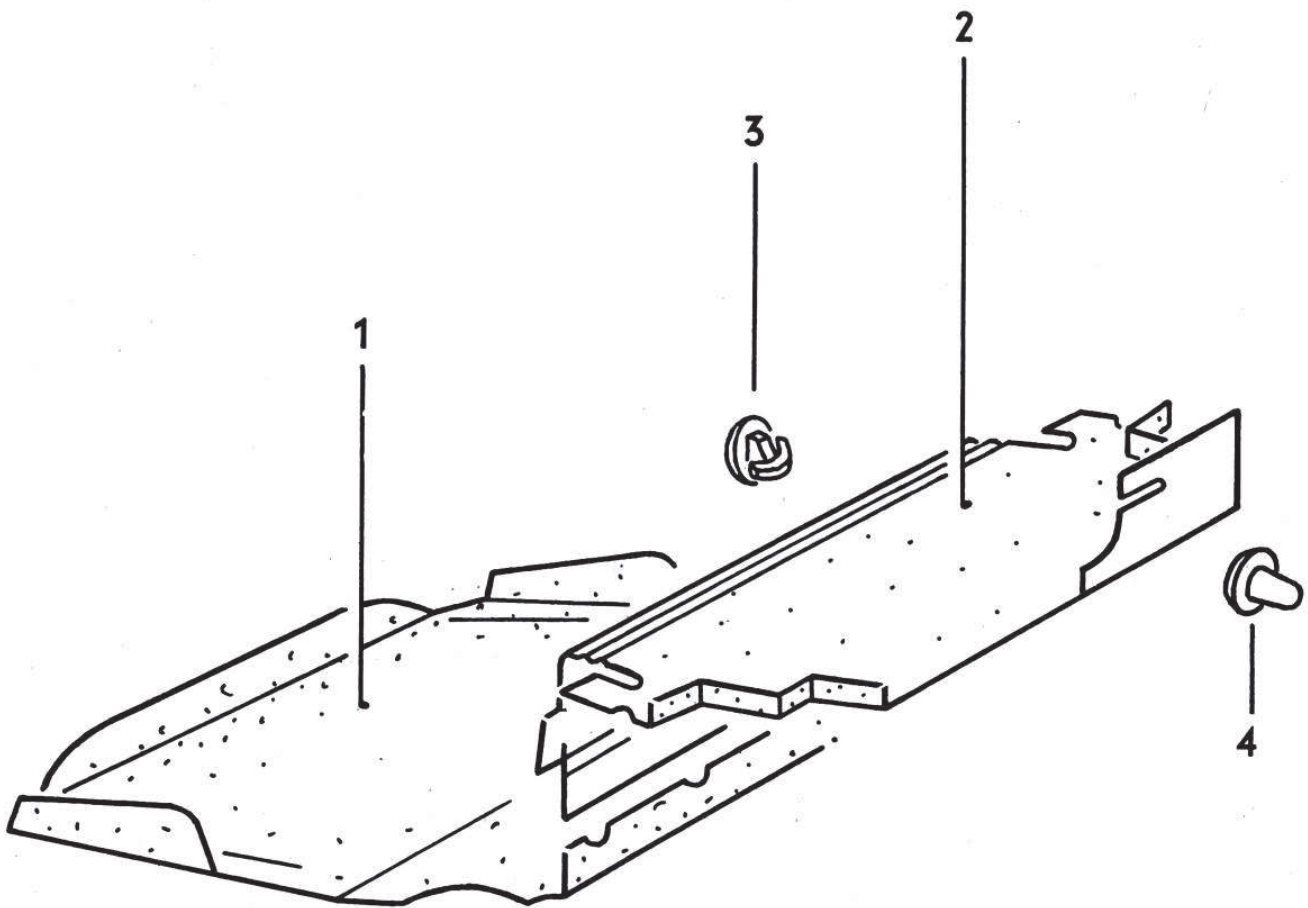

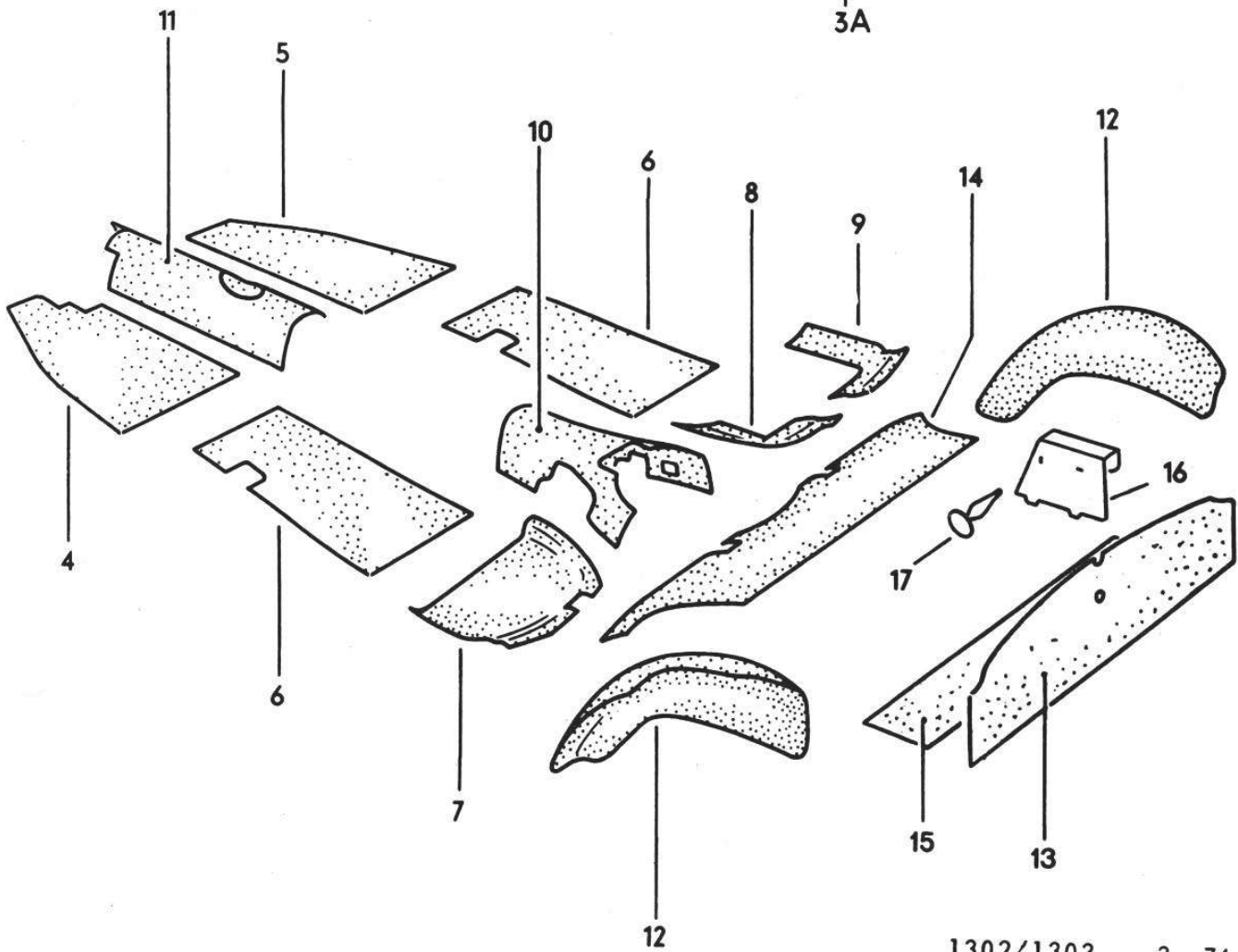
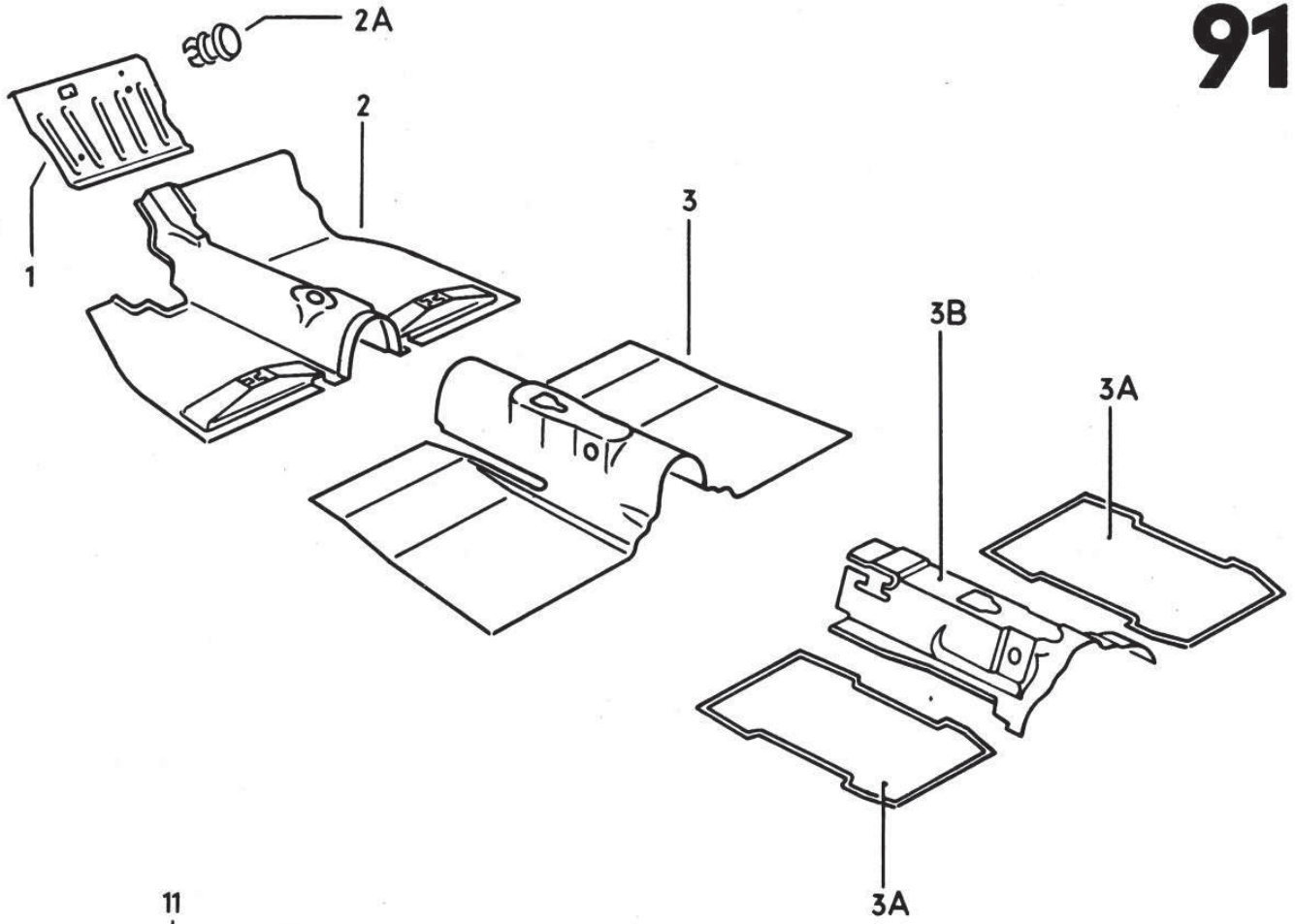

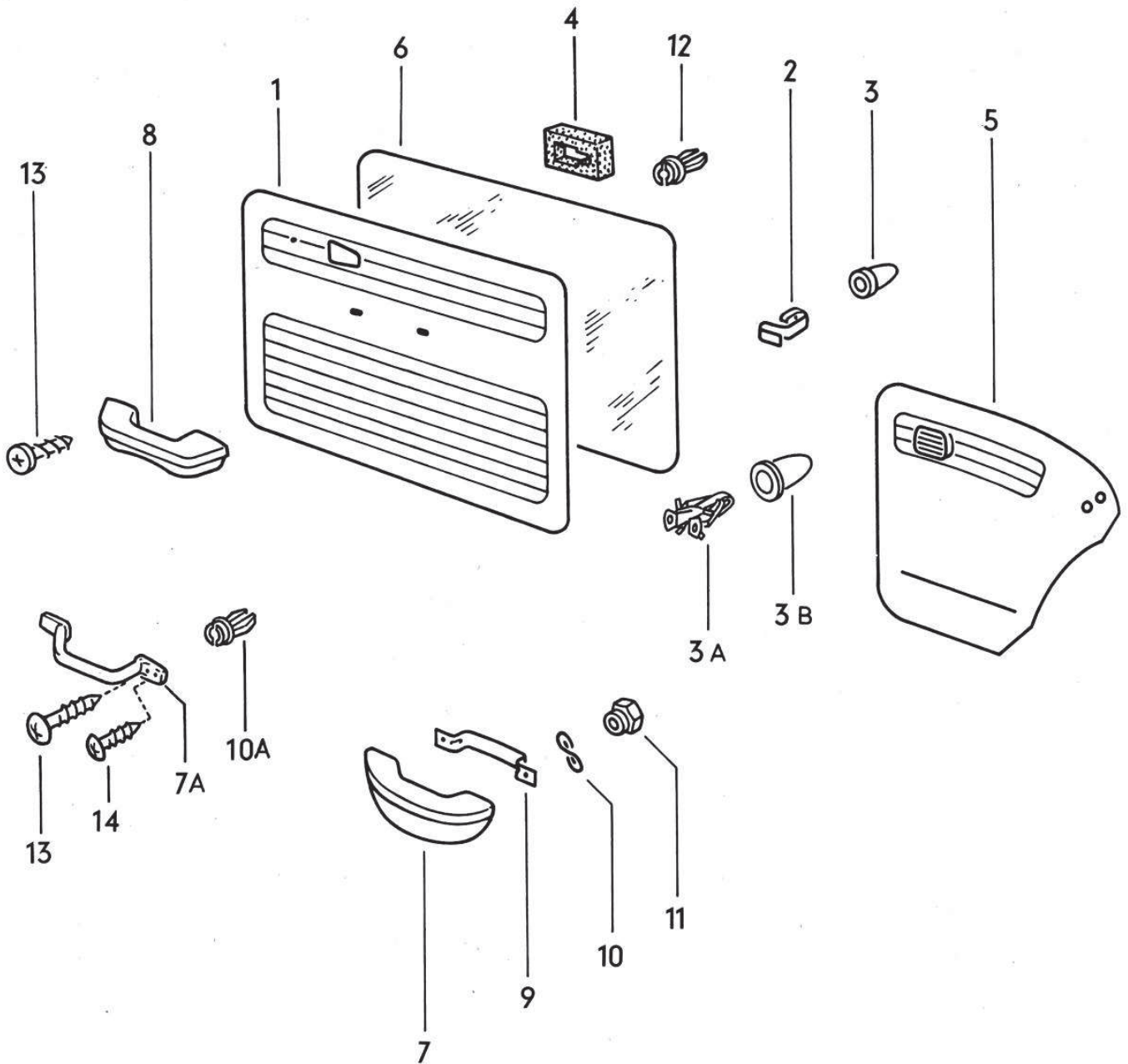

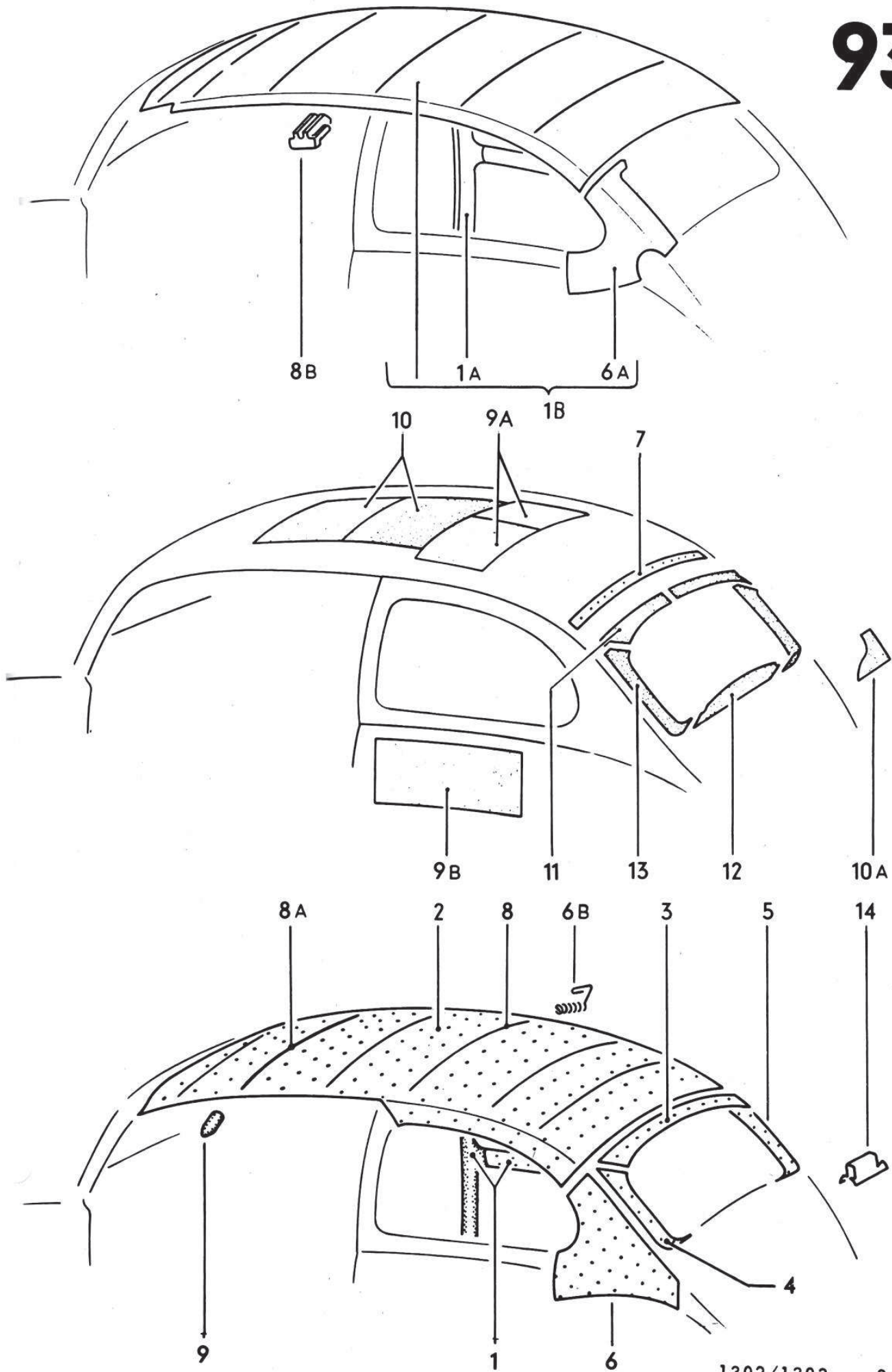

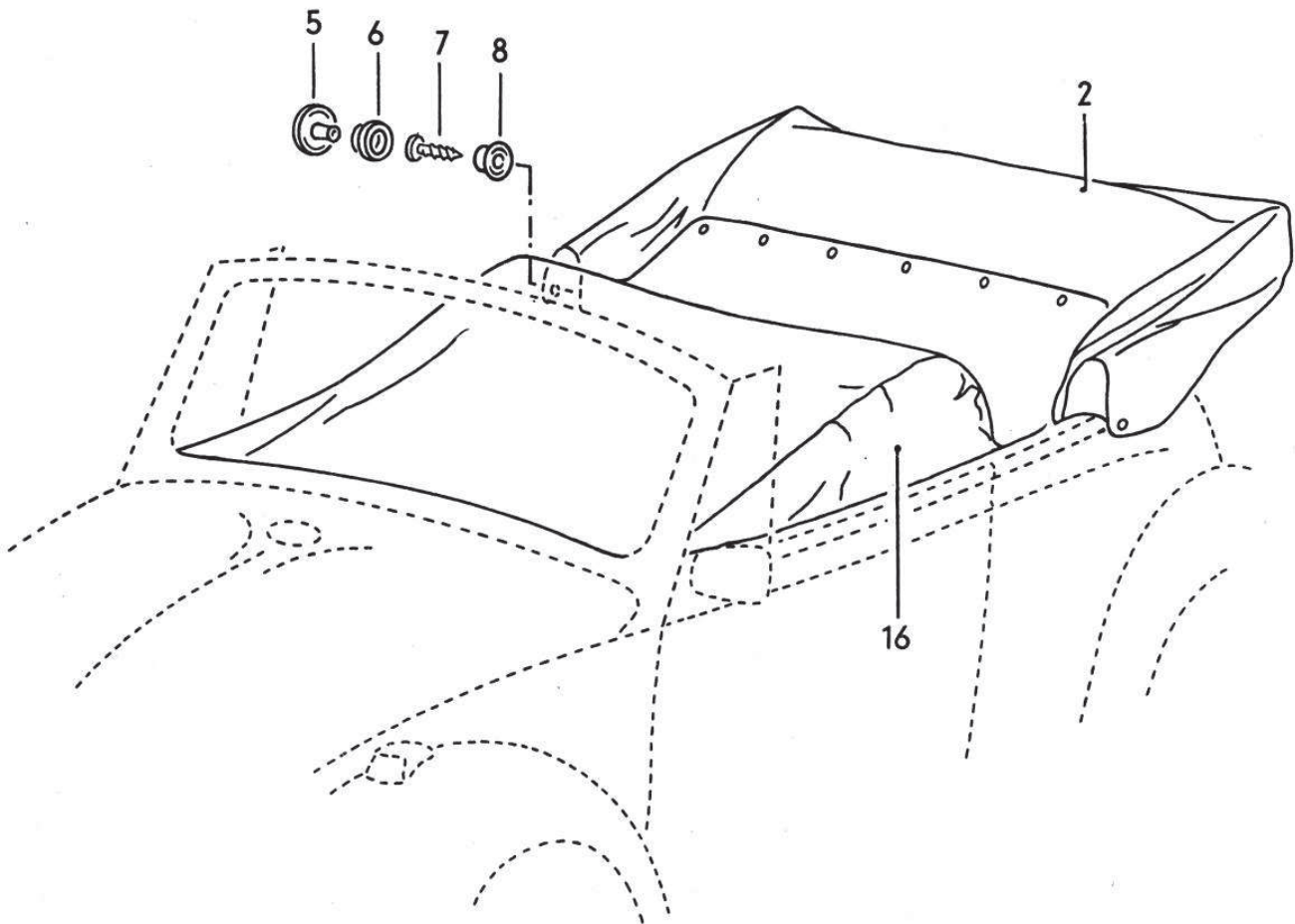
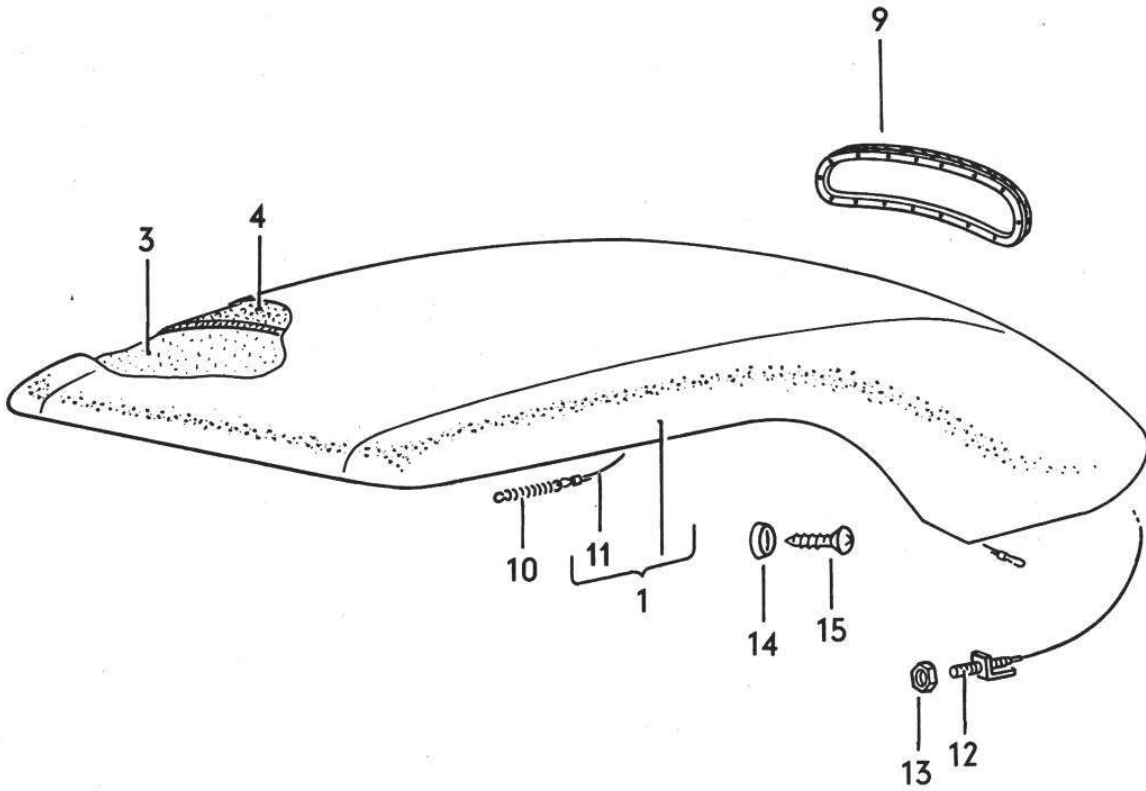

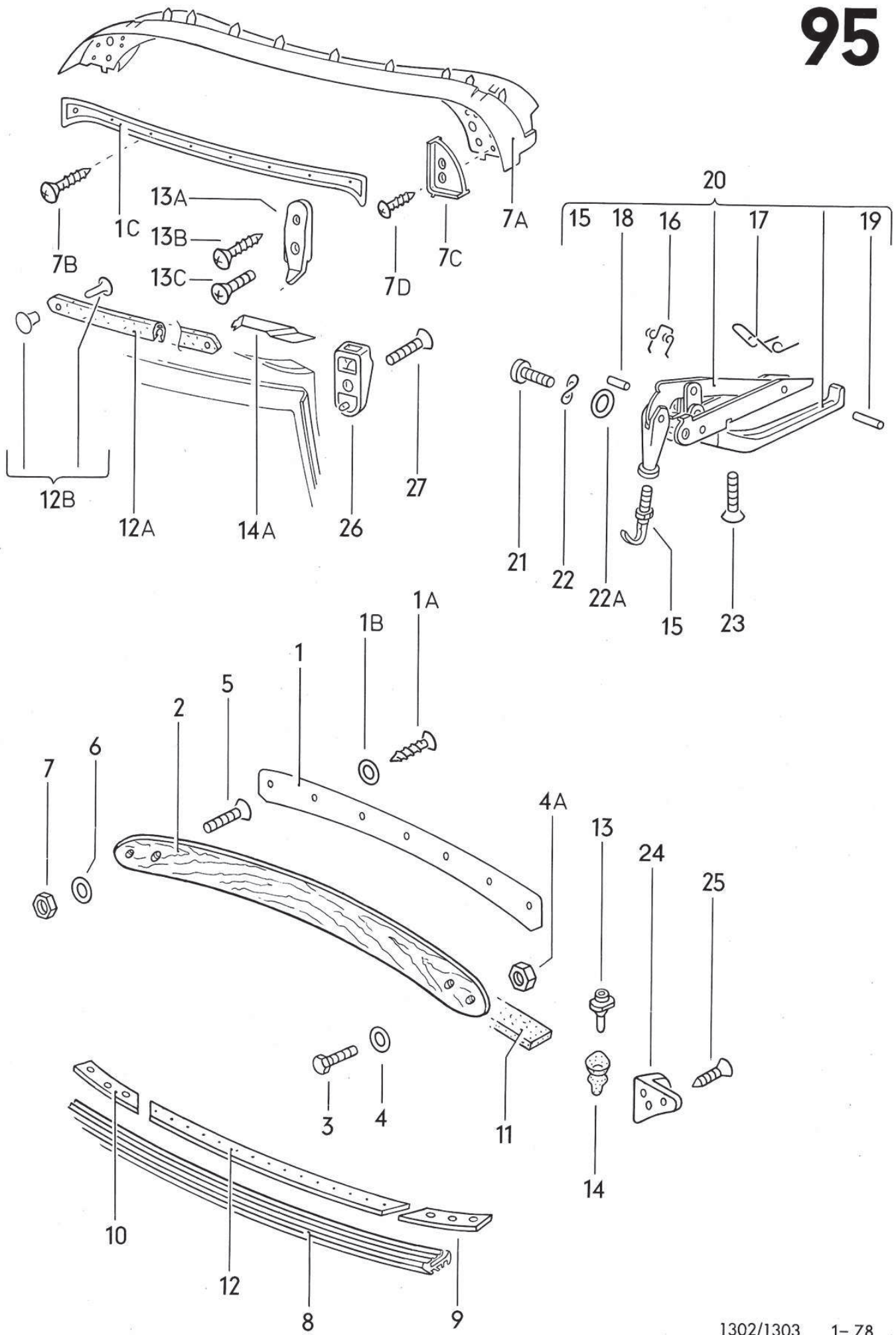

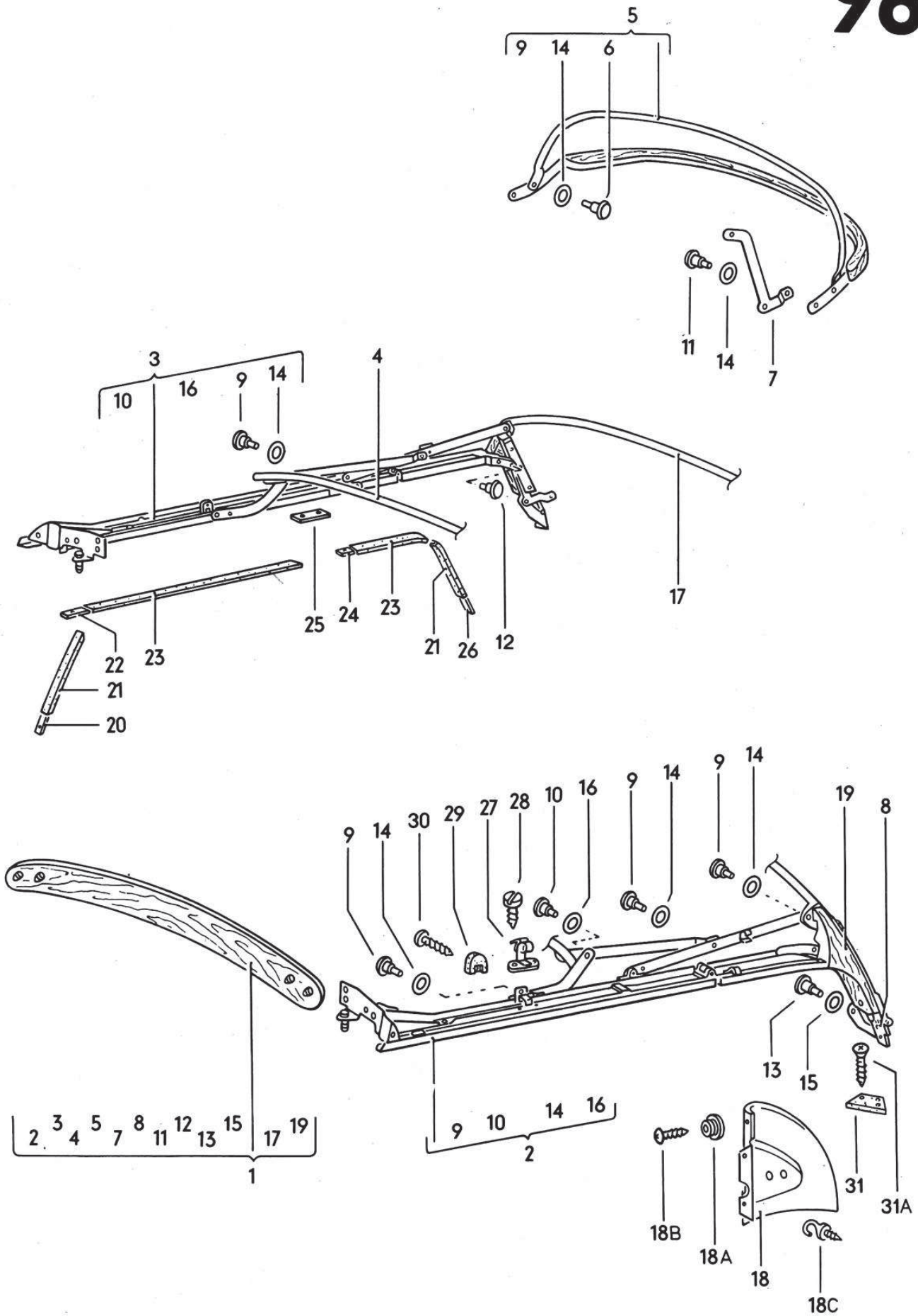

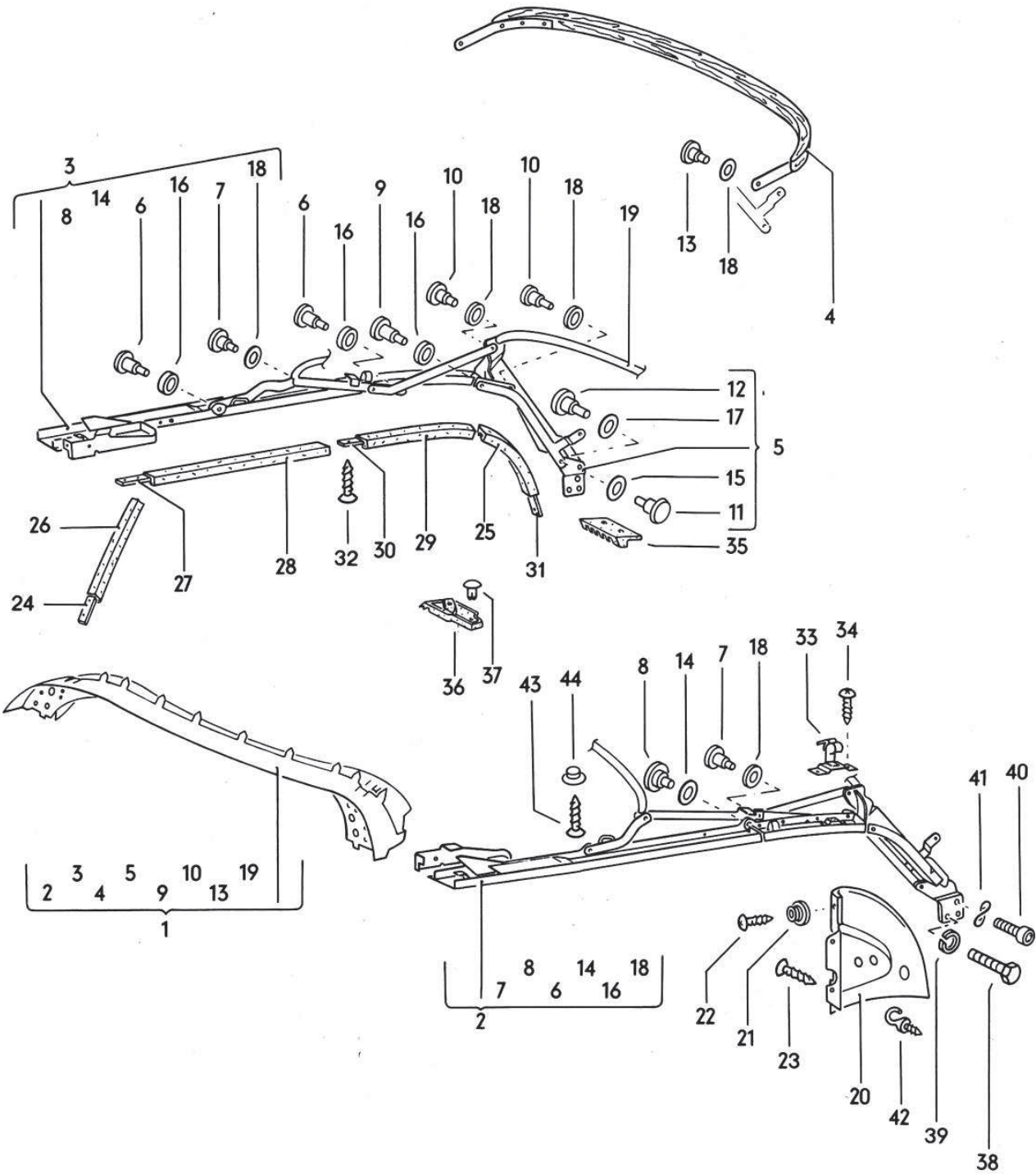

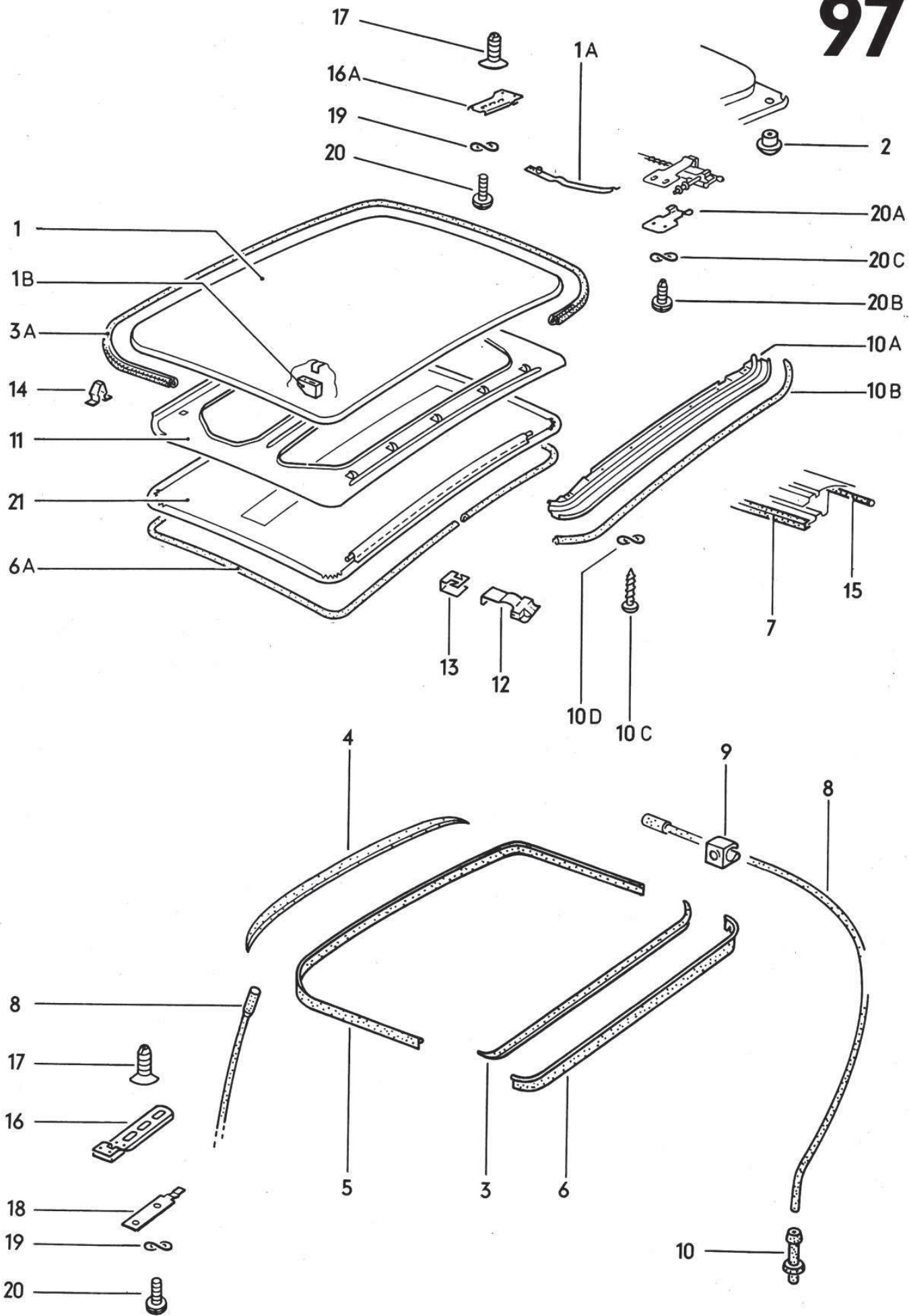

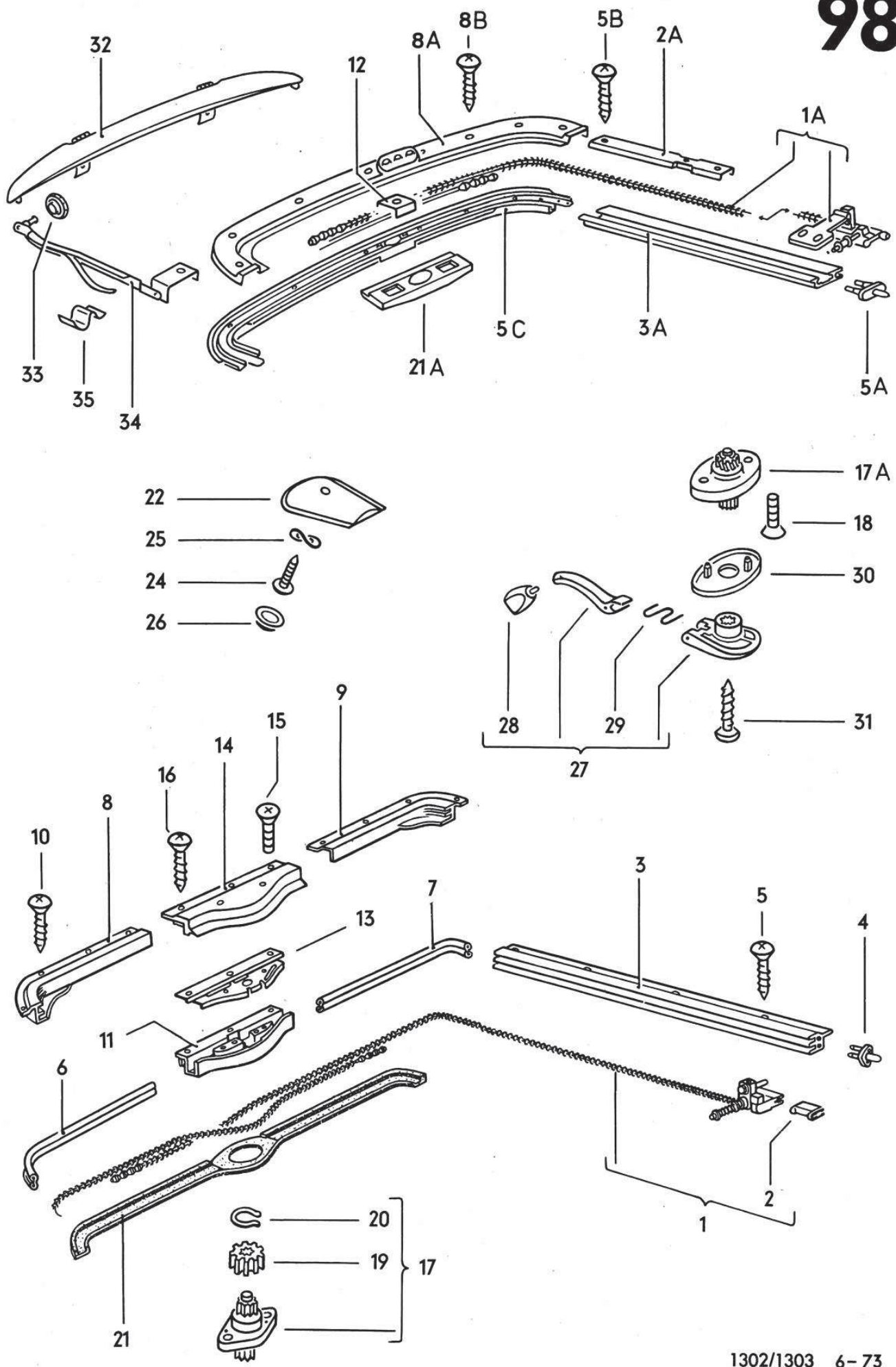

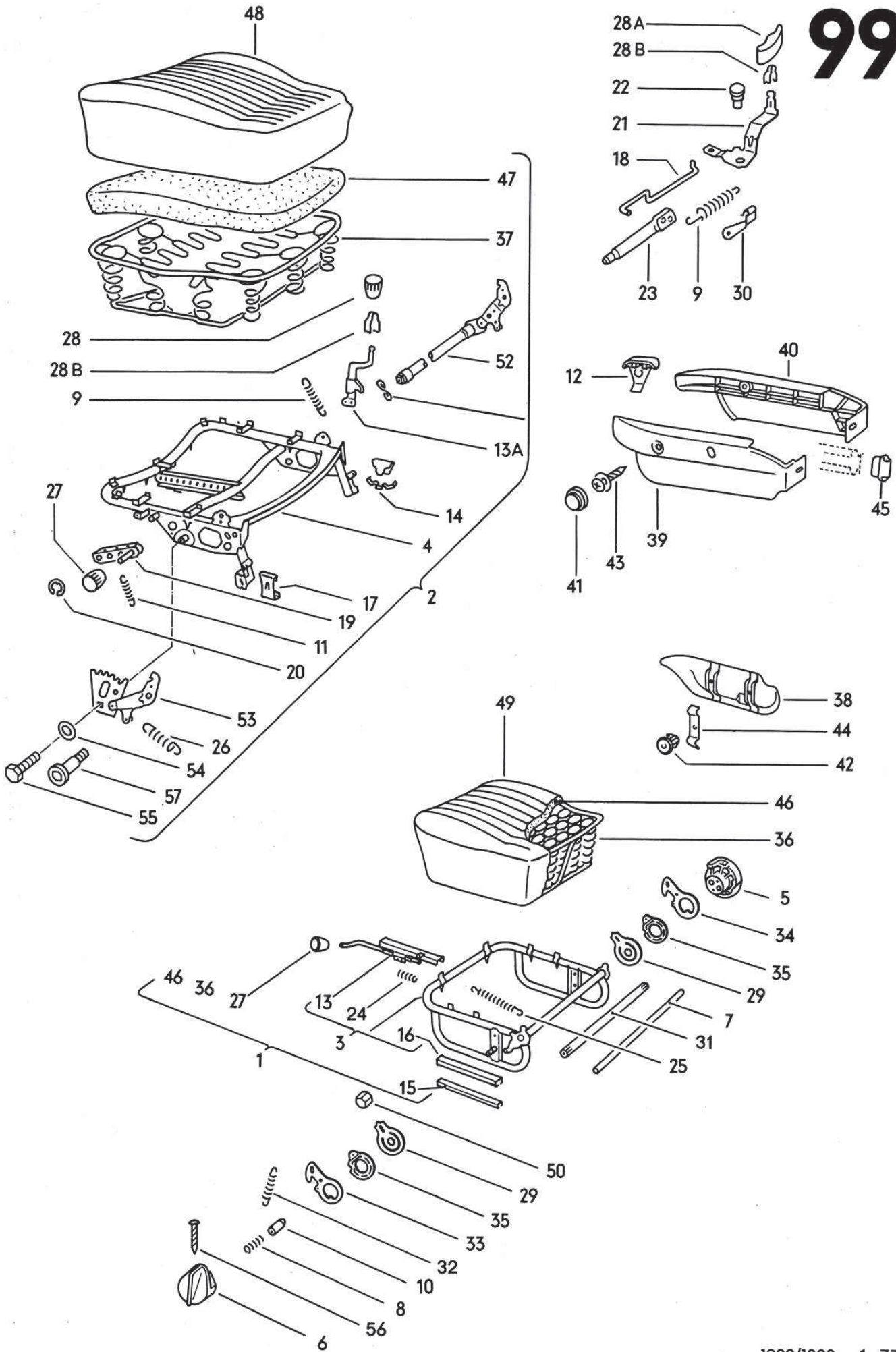

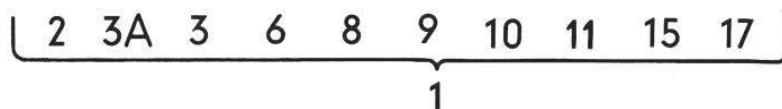
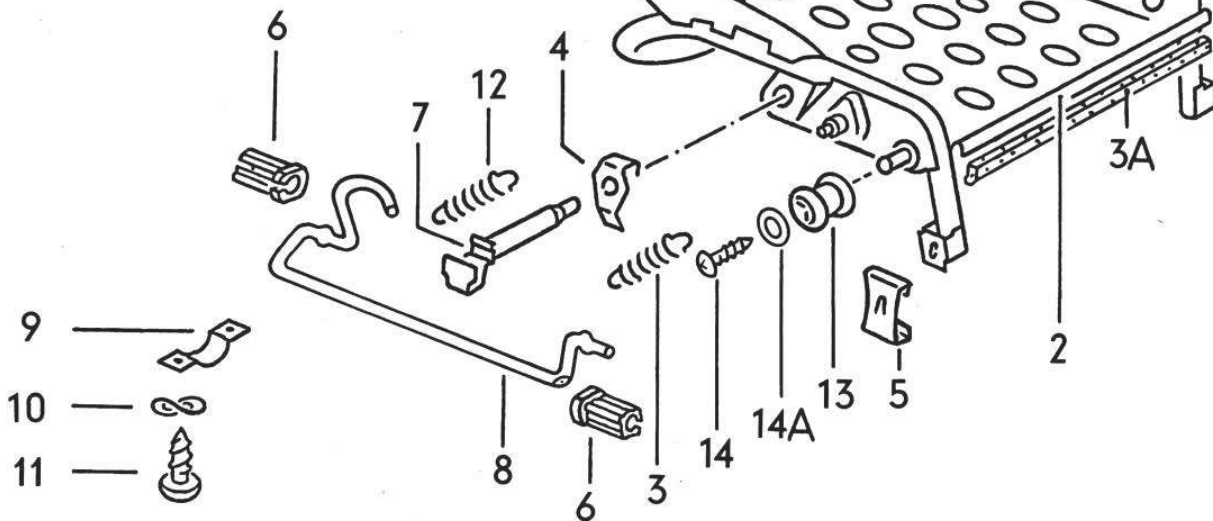
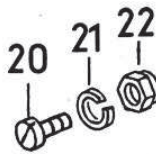
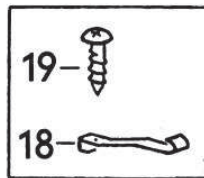
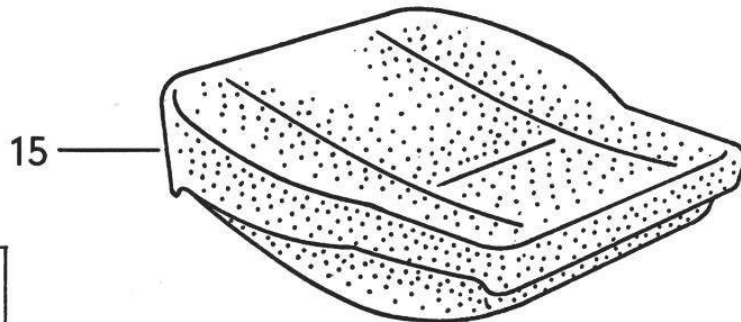
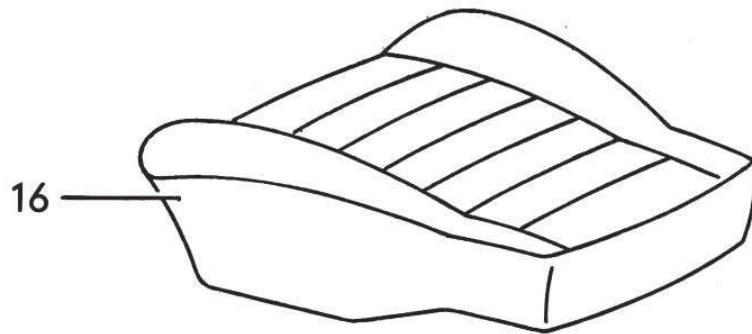

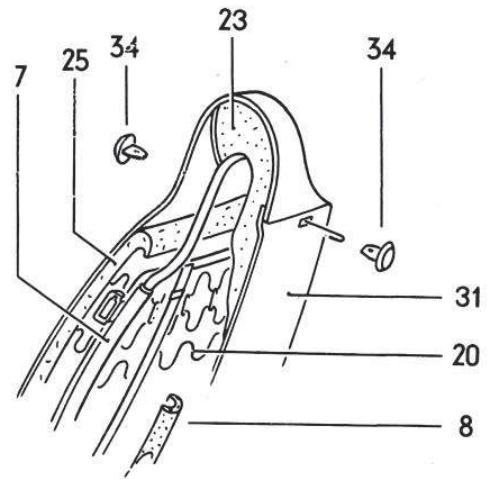
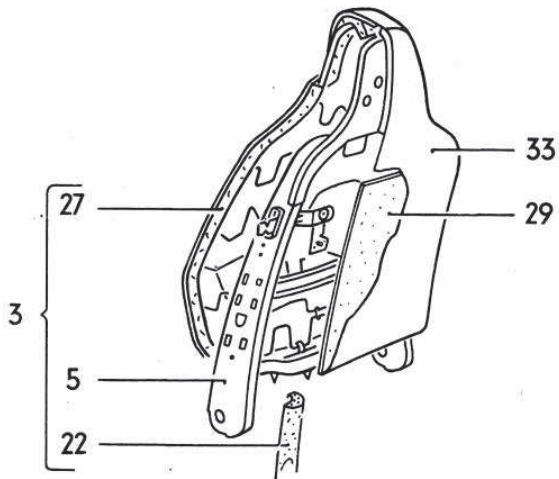
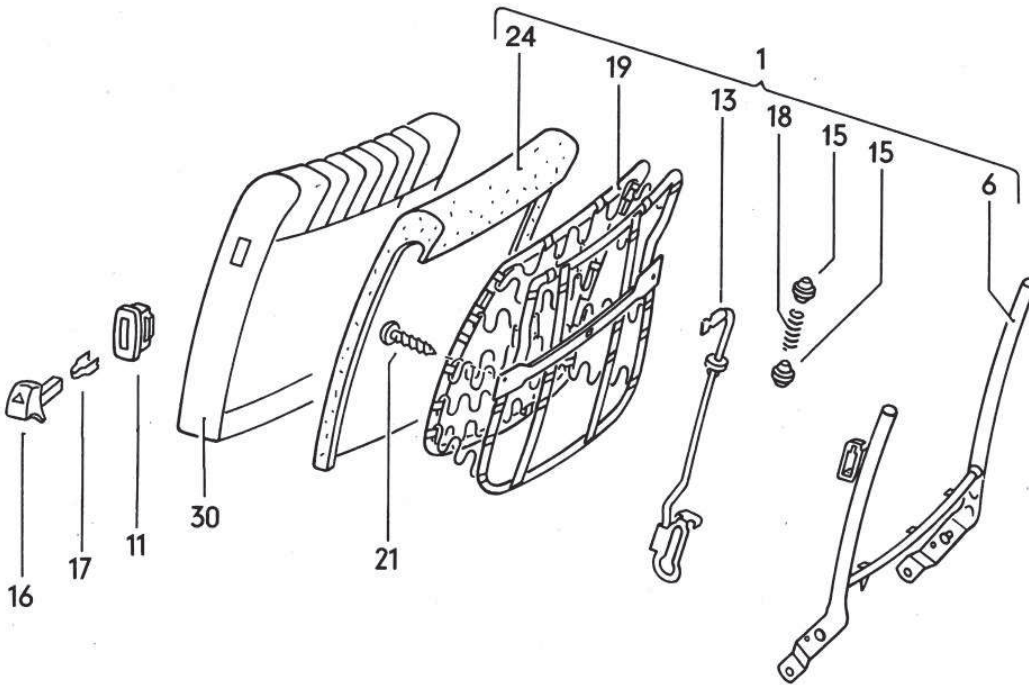
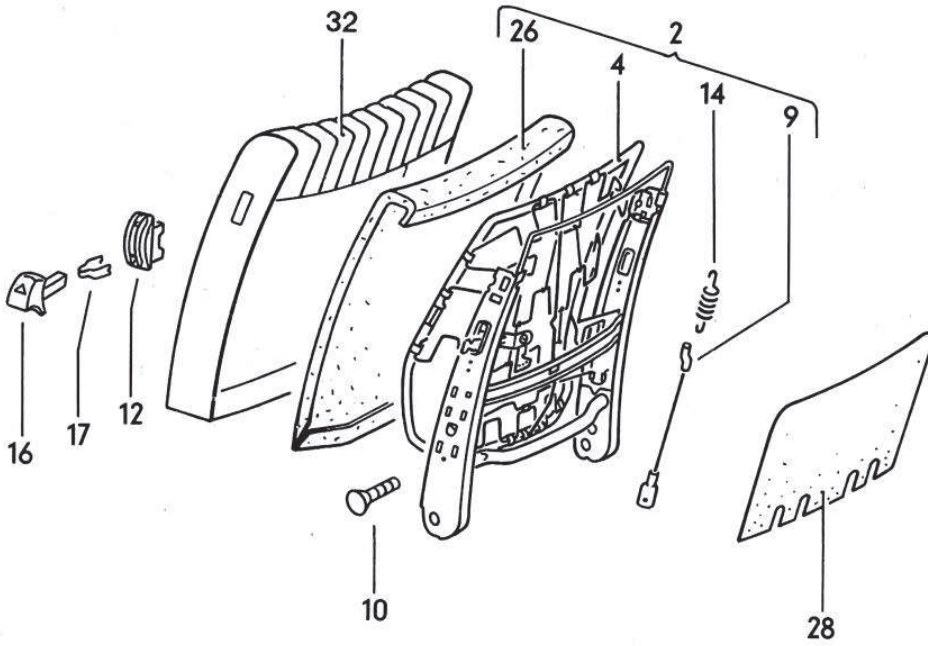

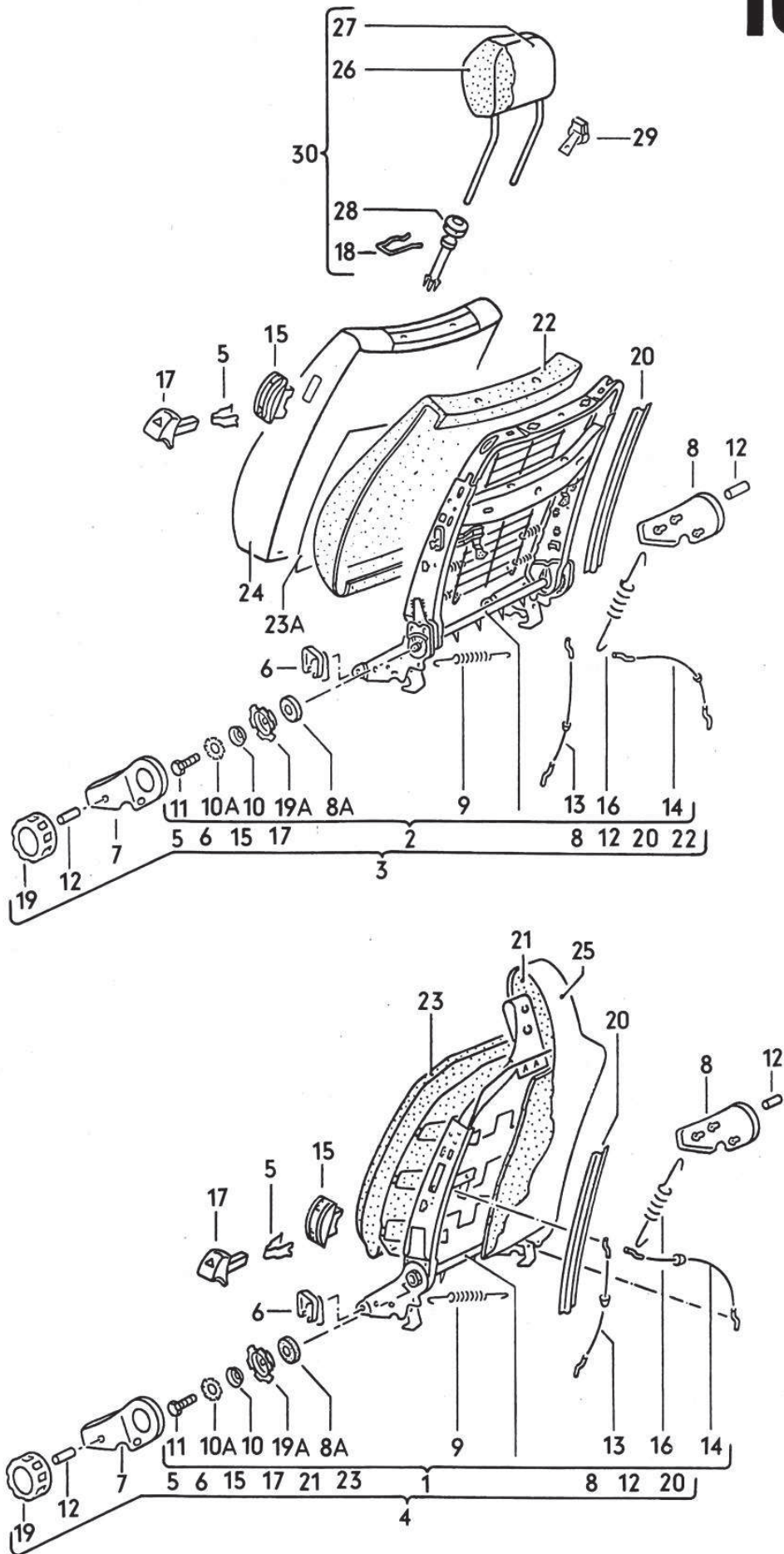

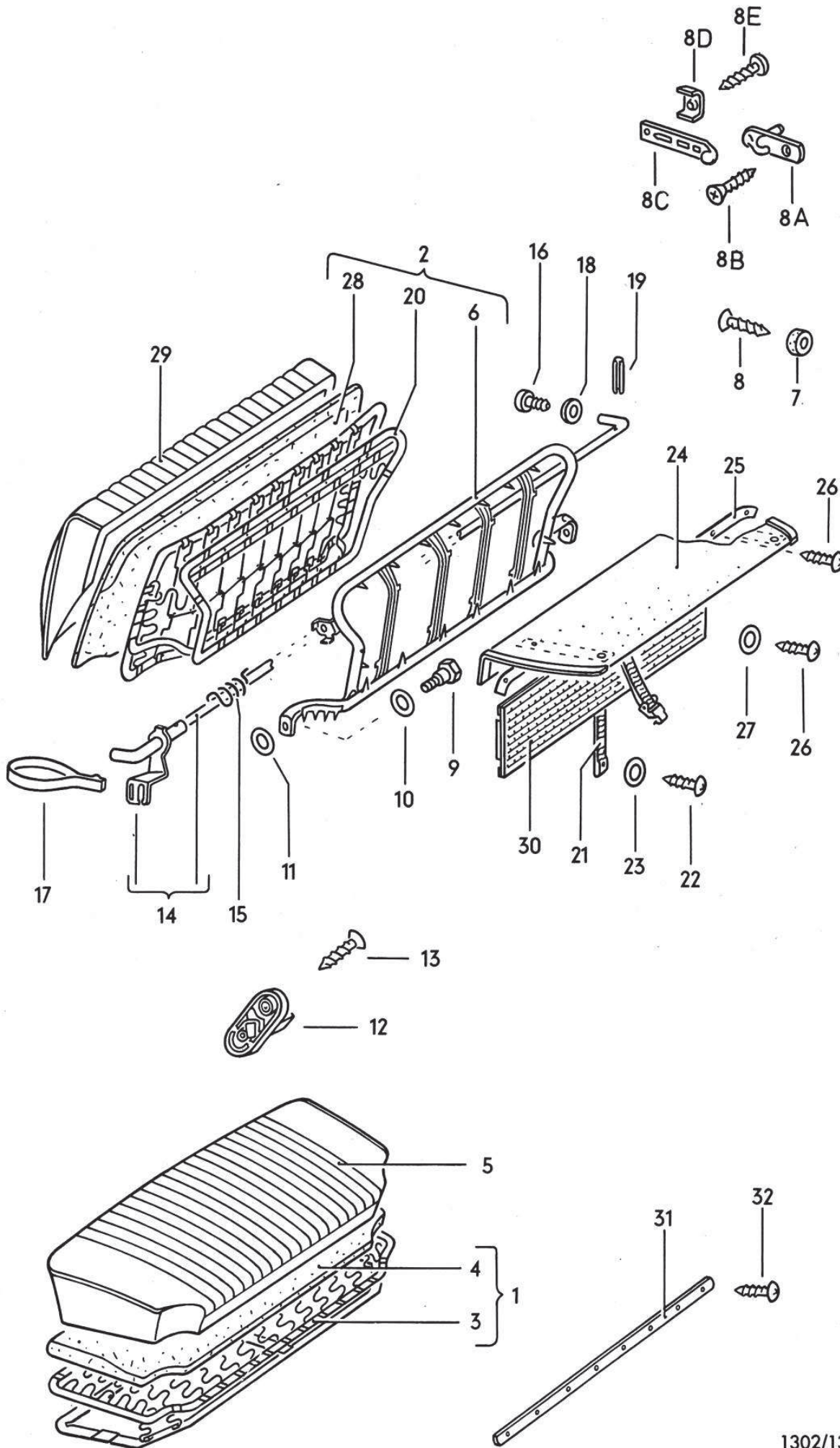

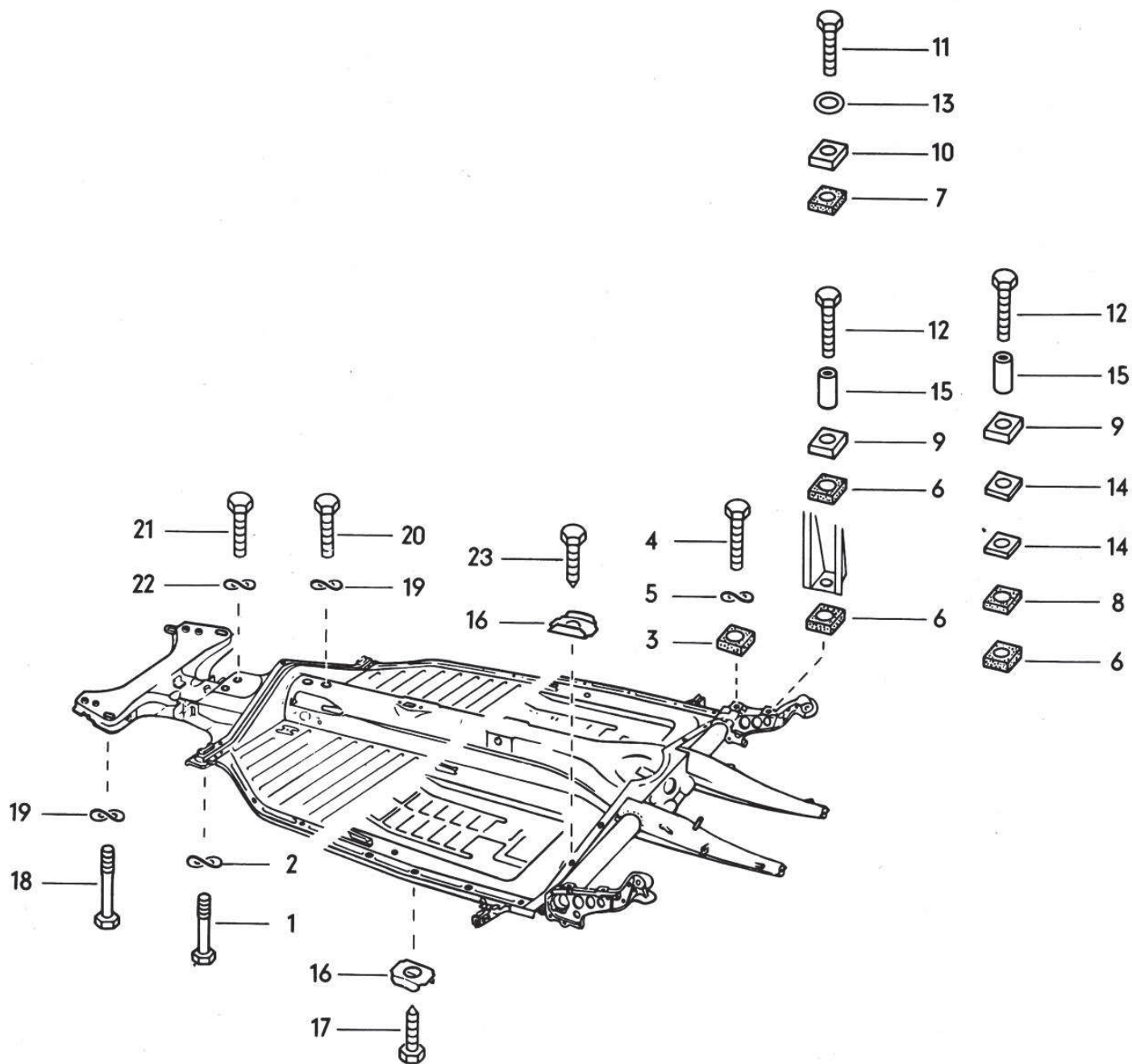

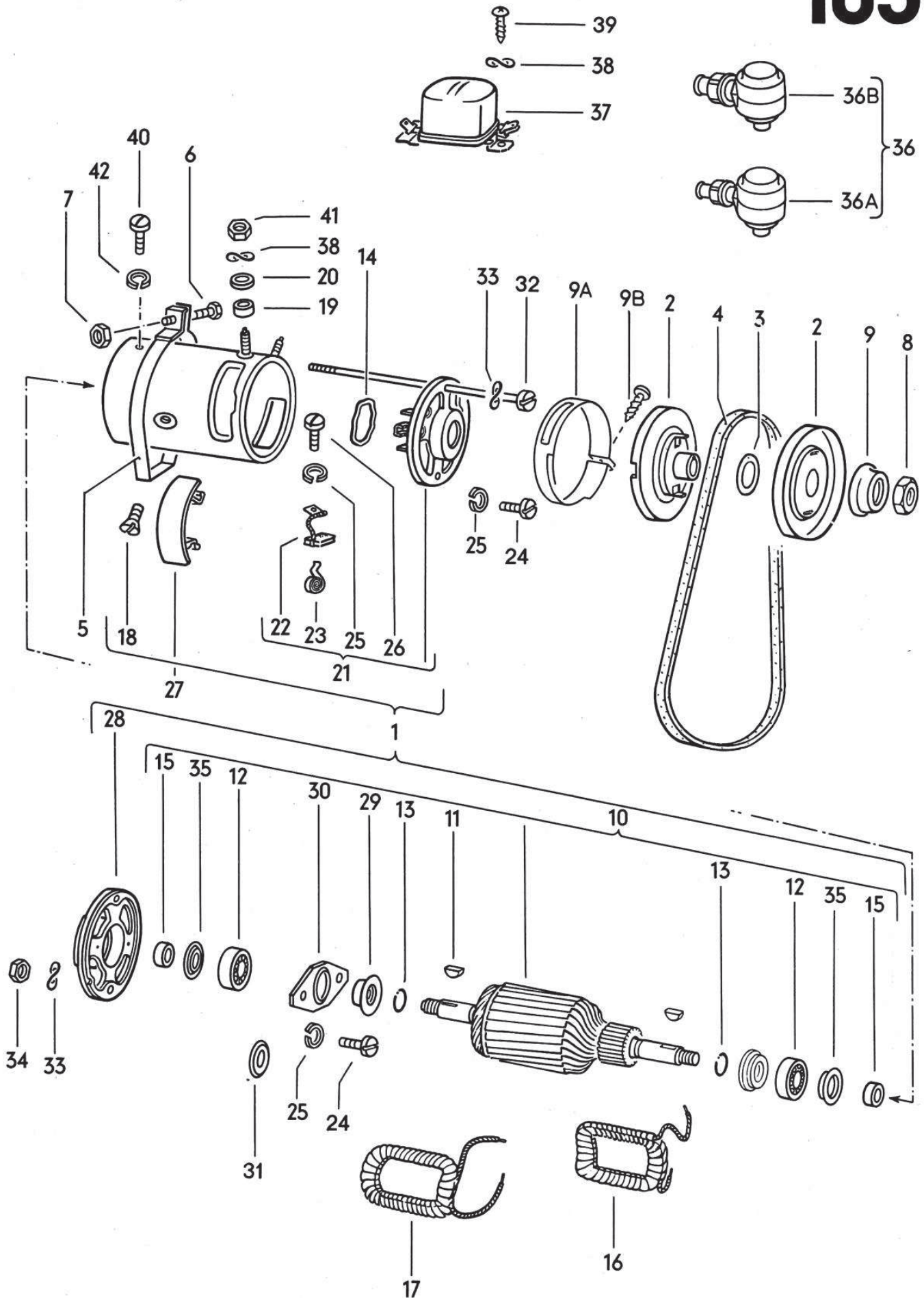

103-10

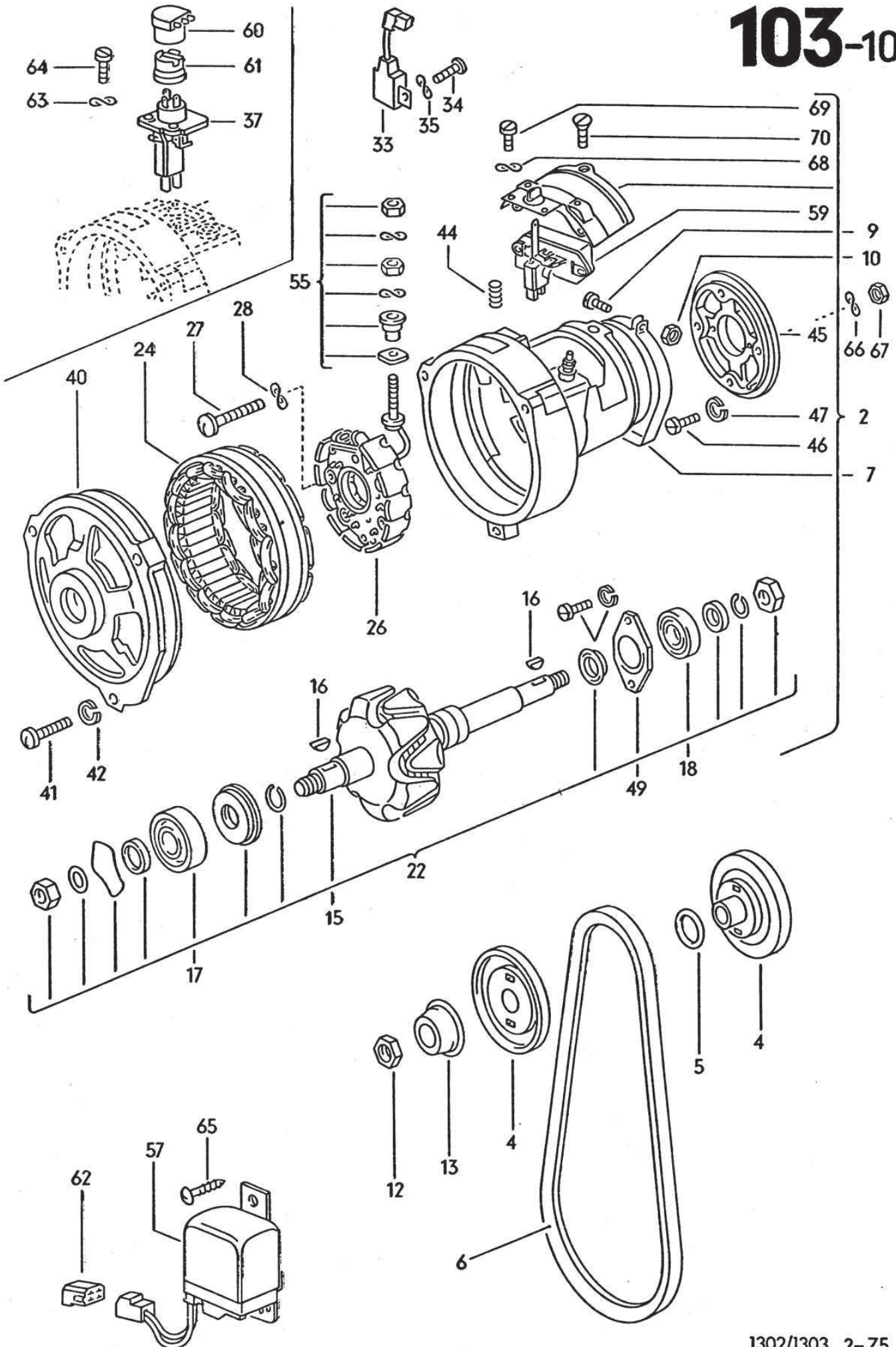

103-20

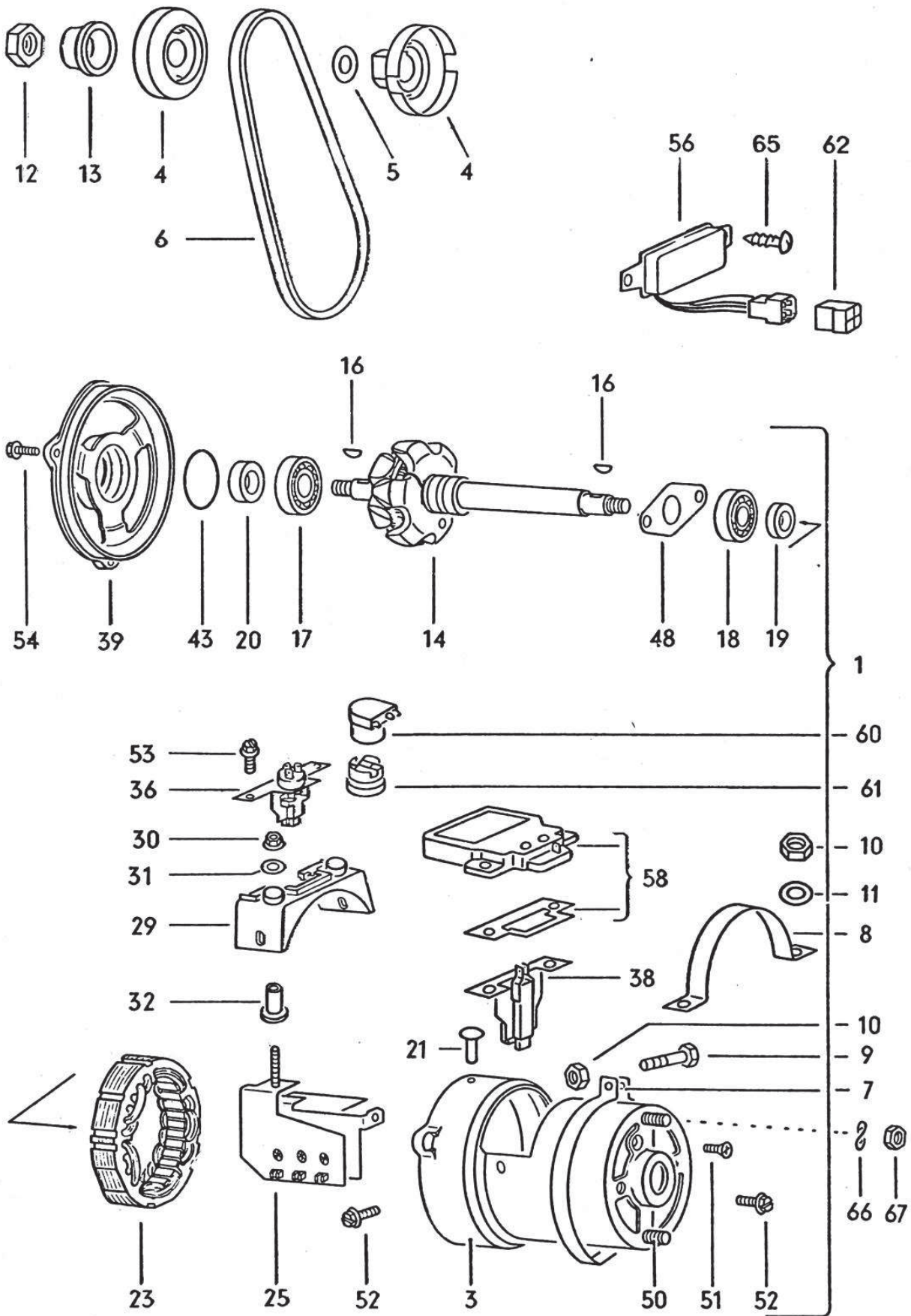

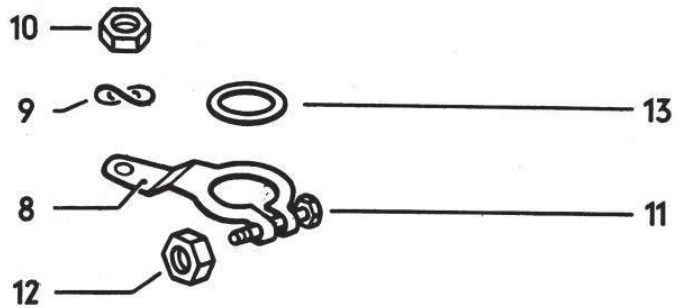
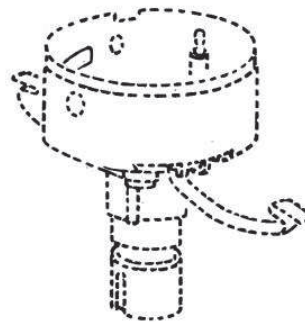
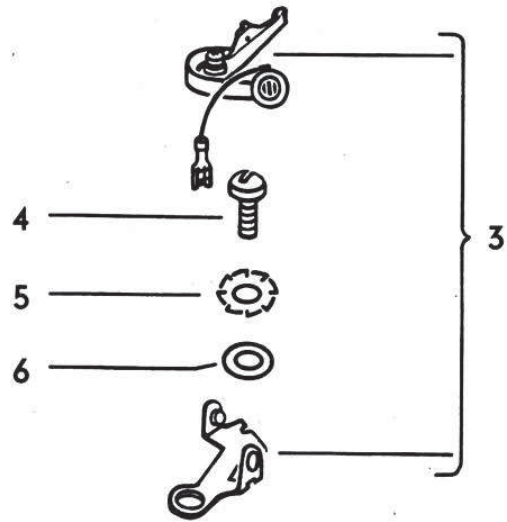
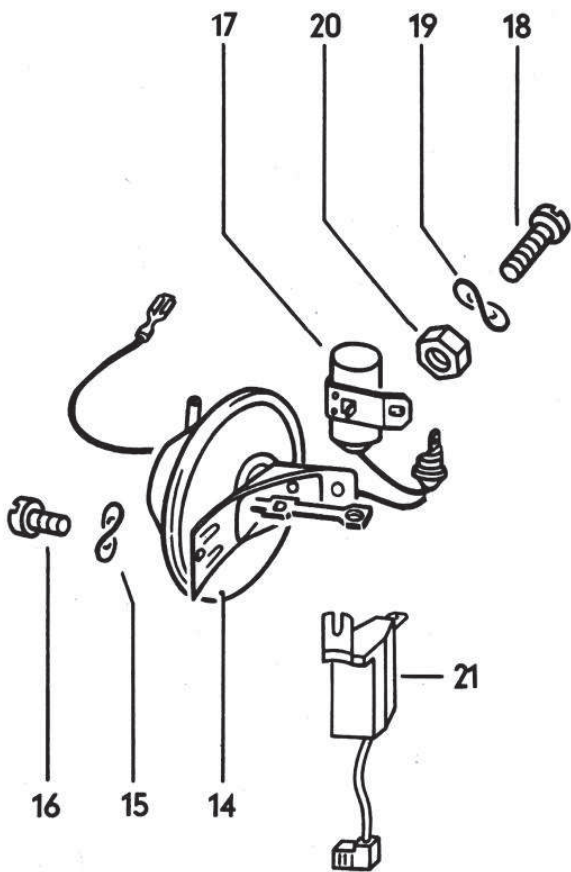
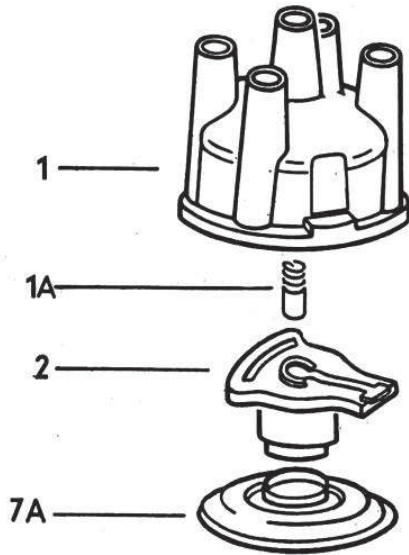

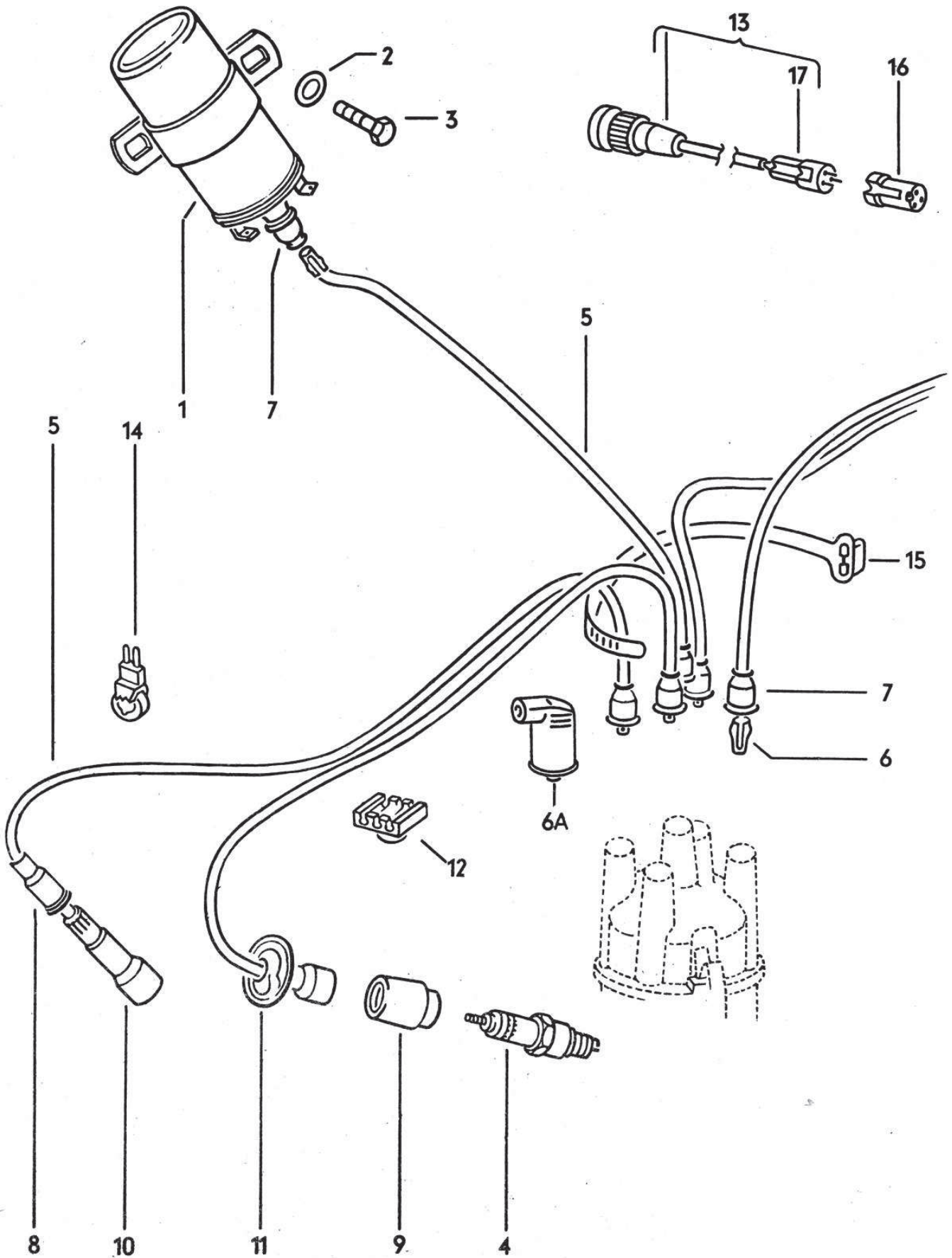

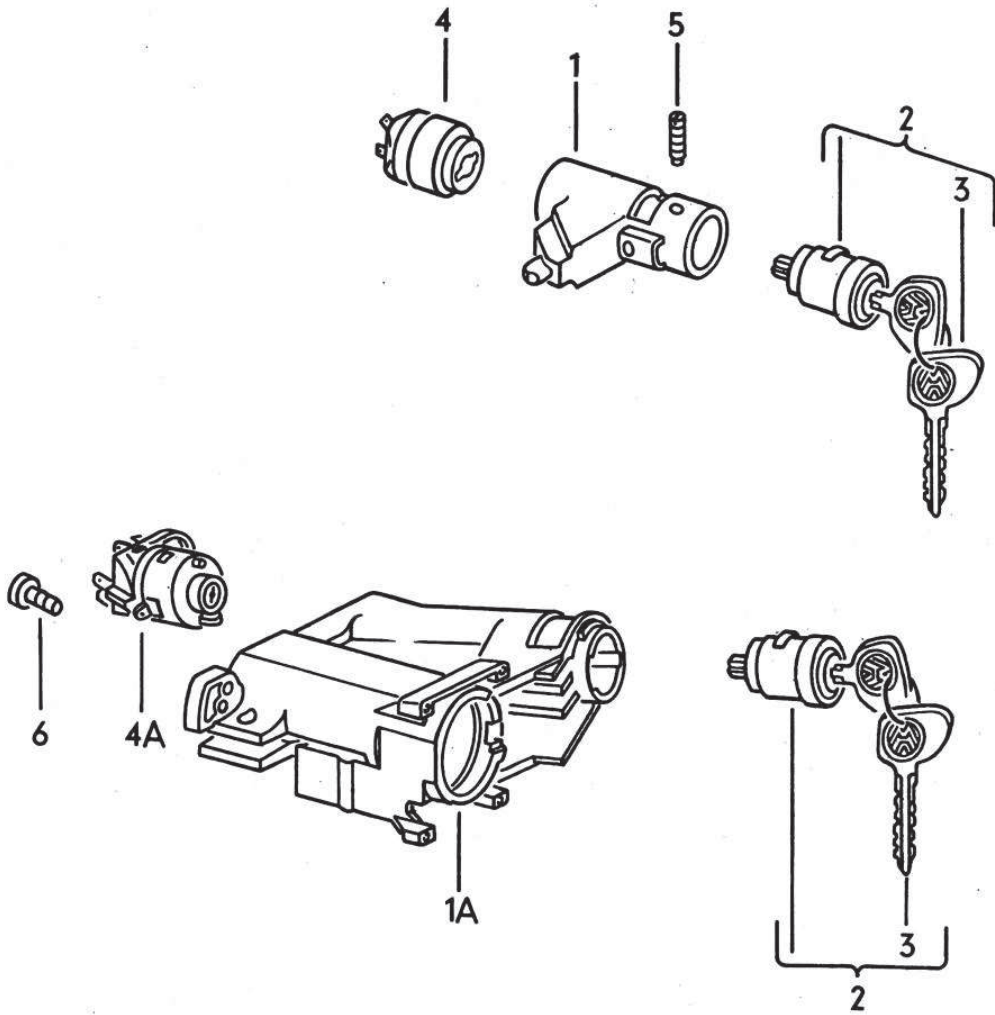

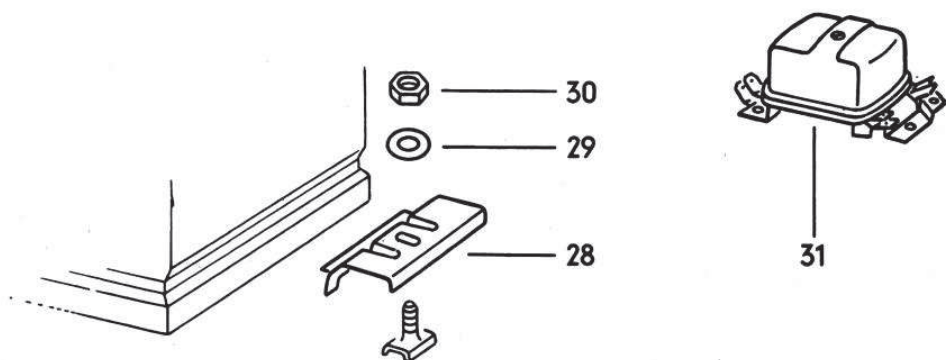
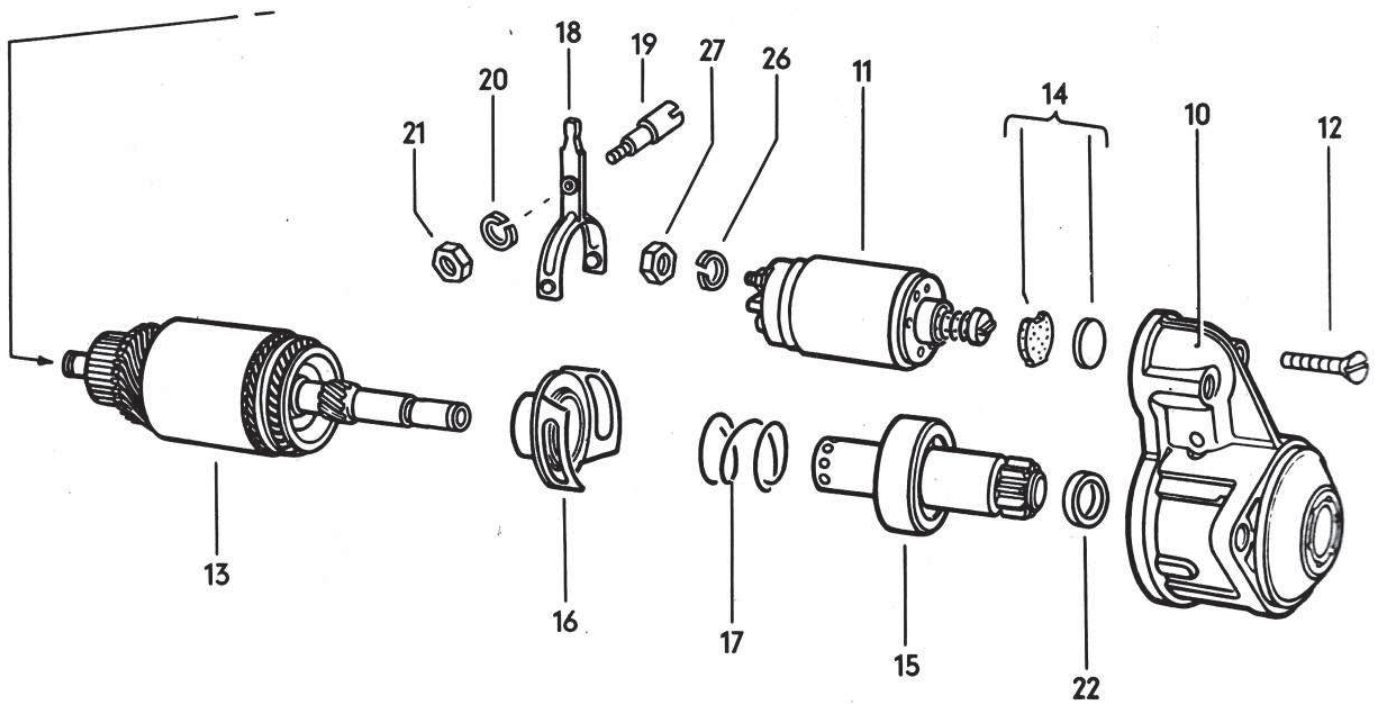
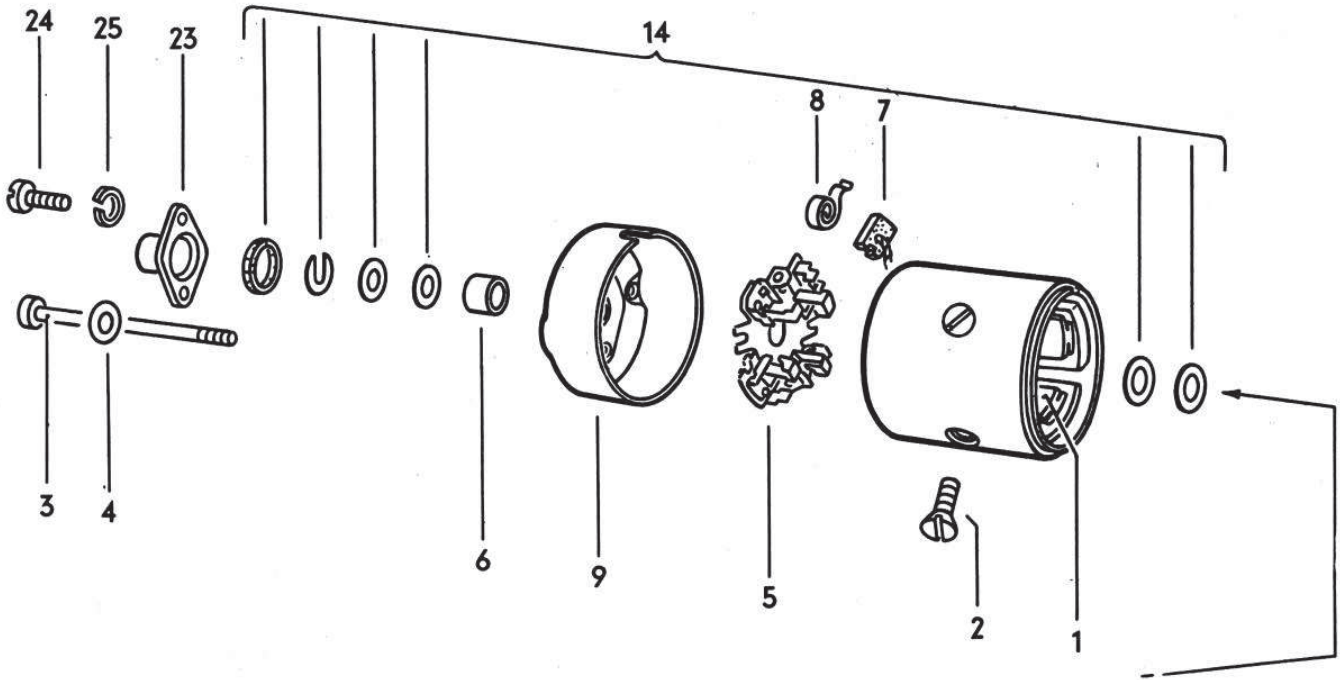

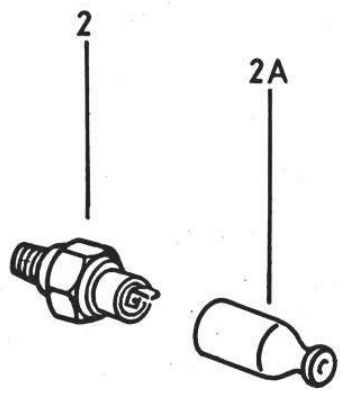
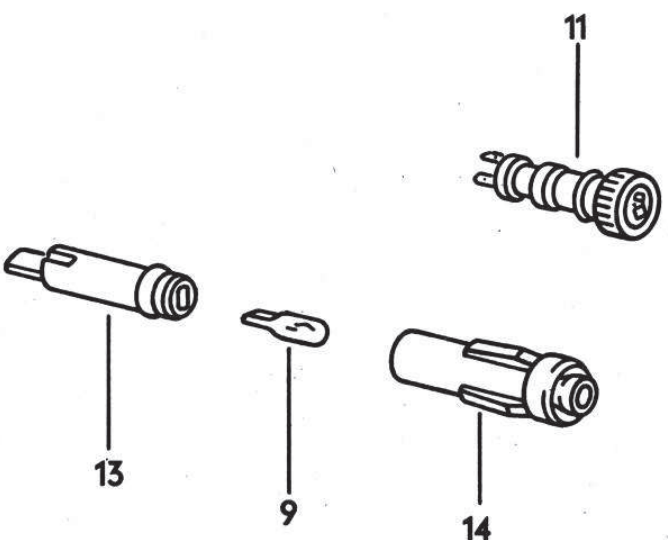
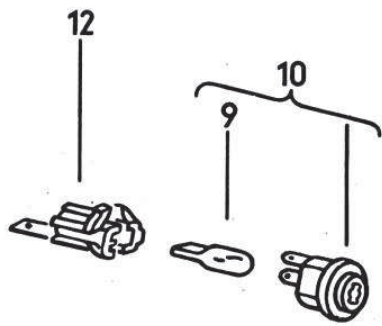
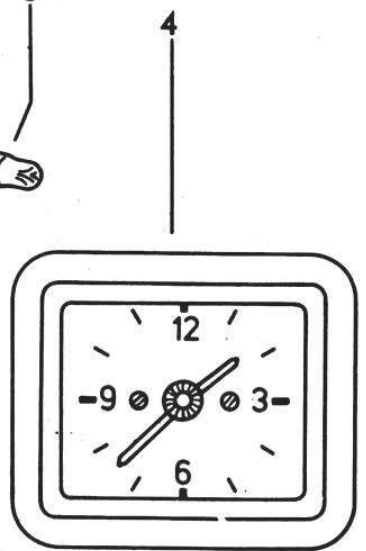
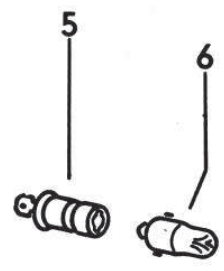
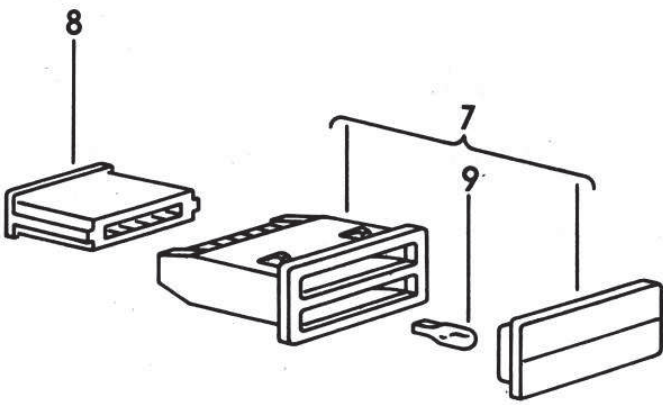
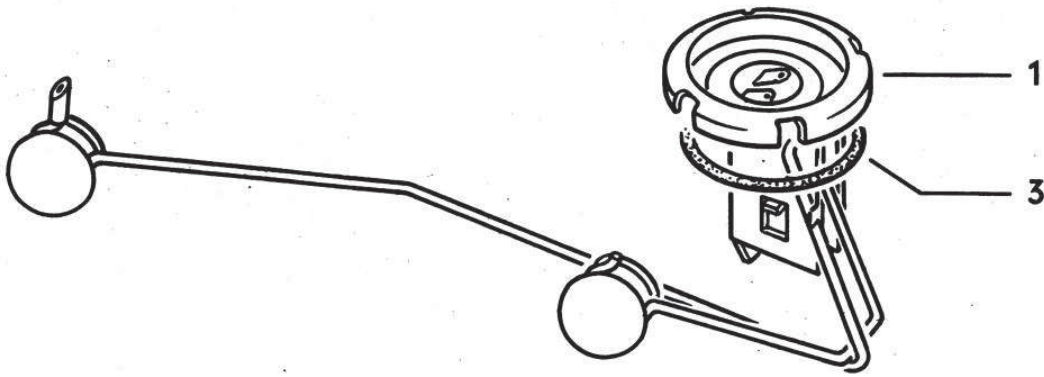

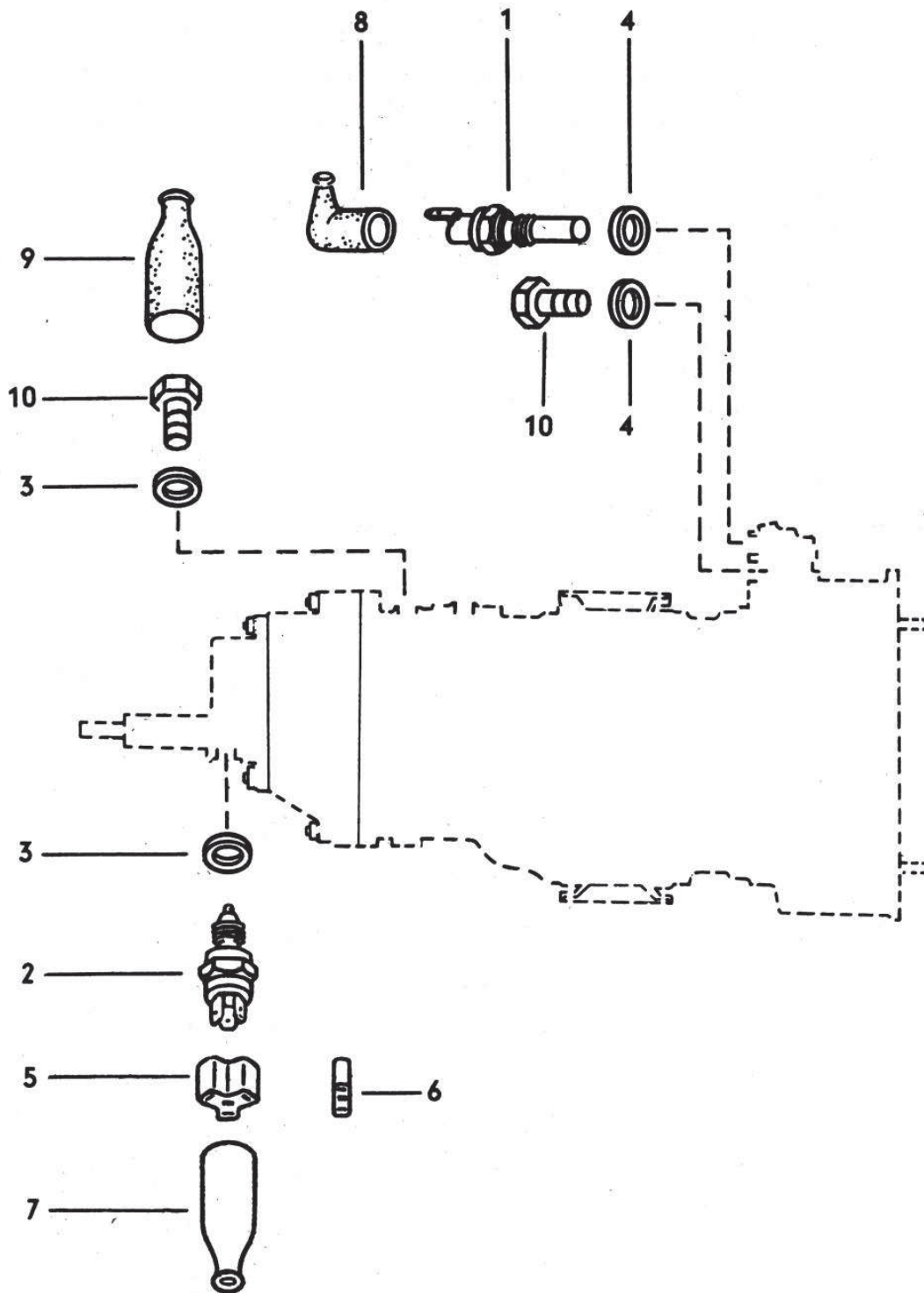

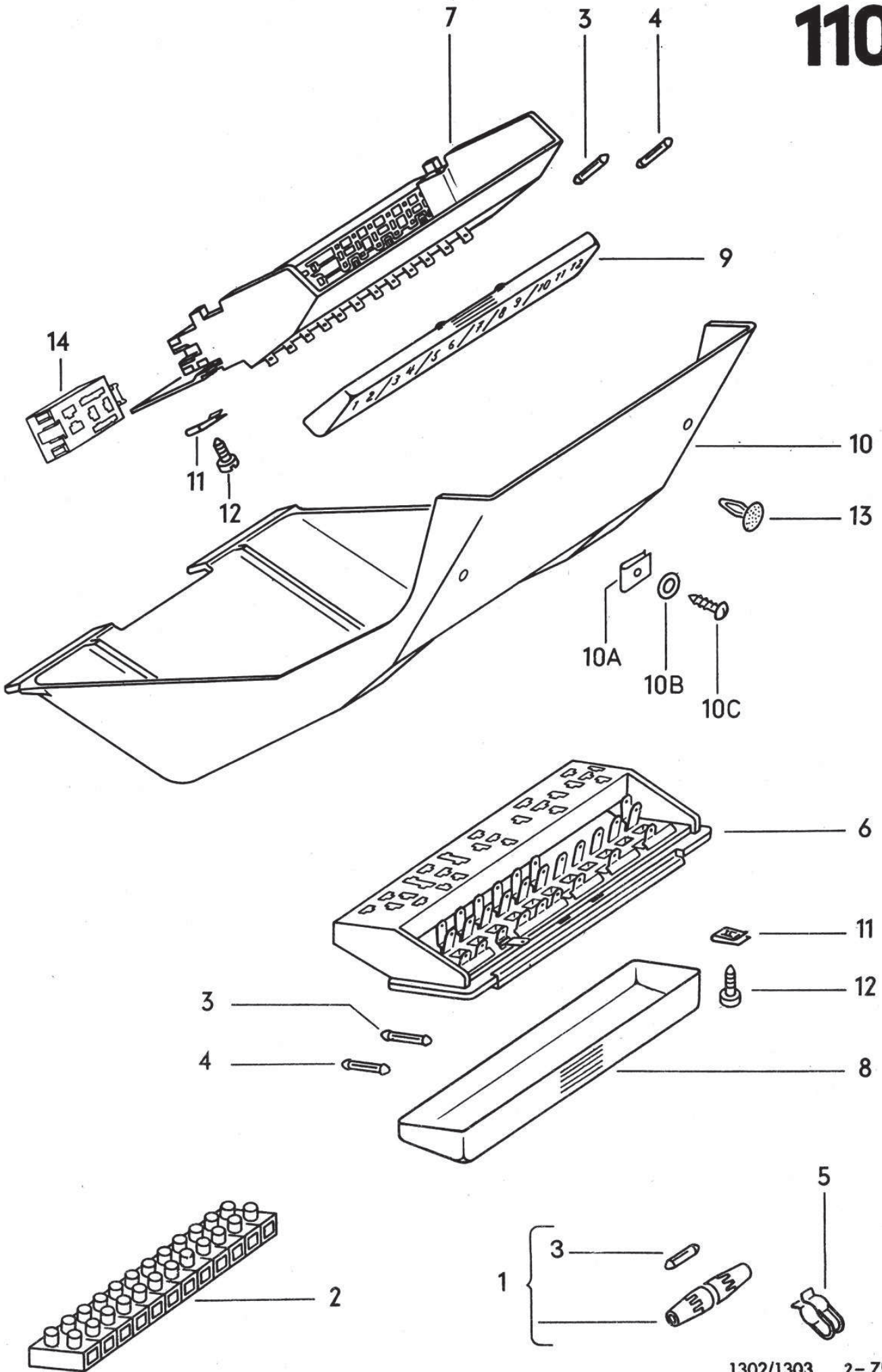

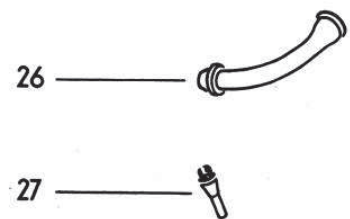
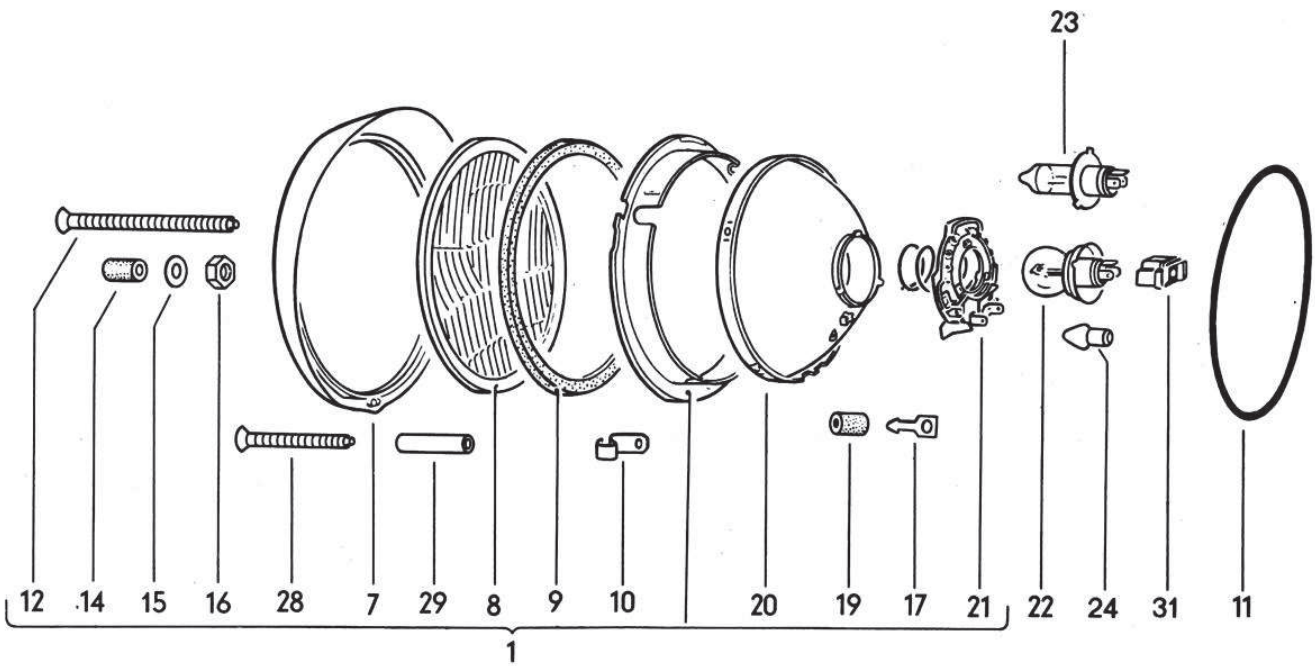
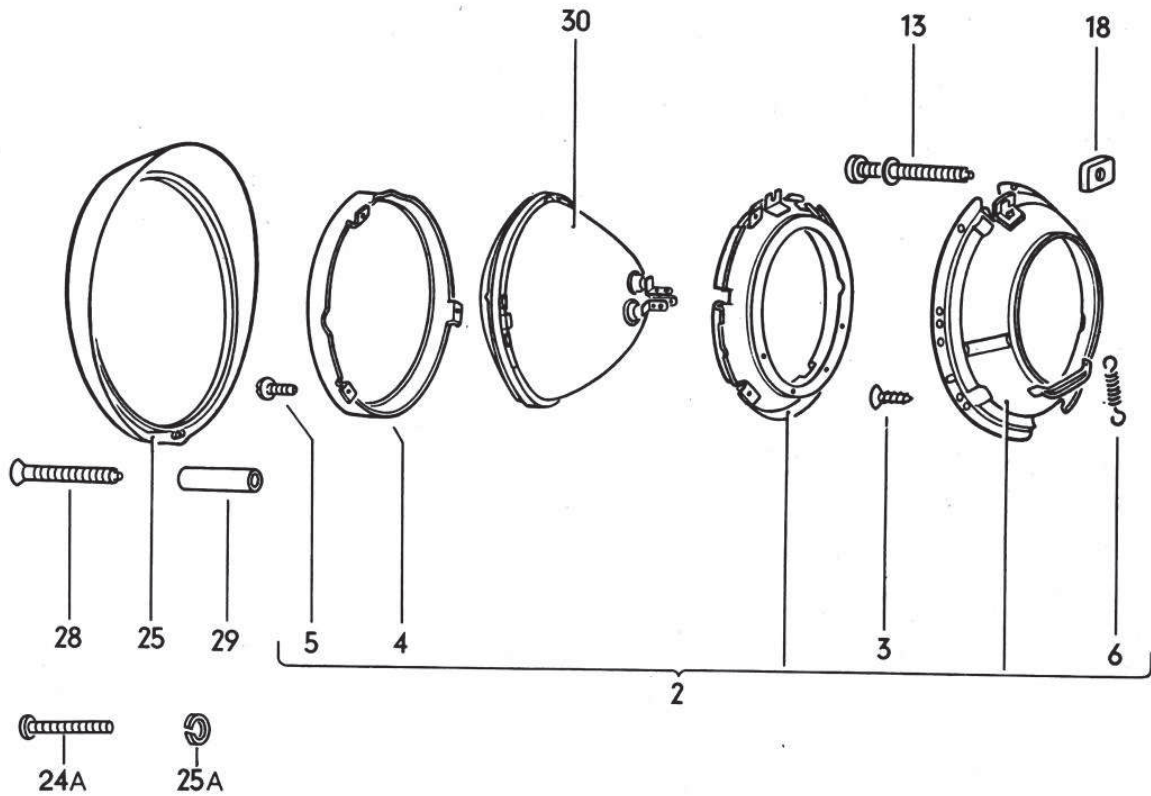

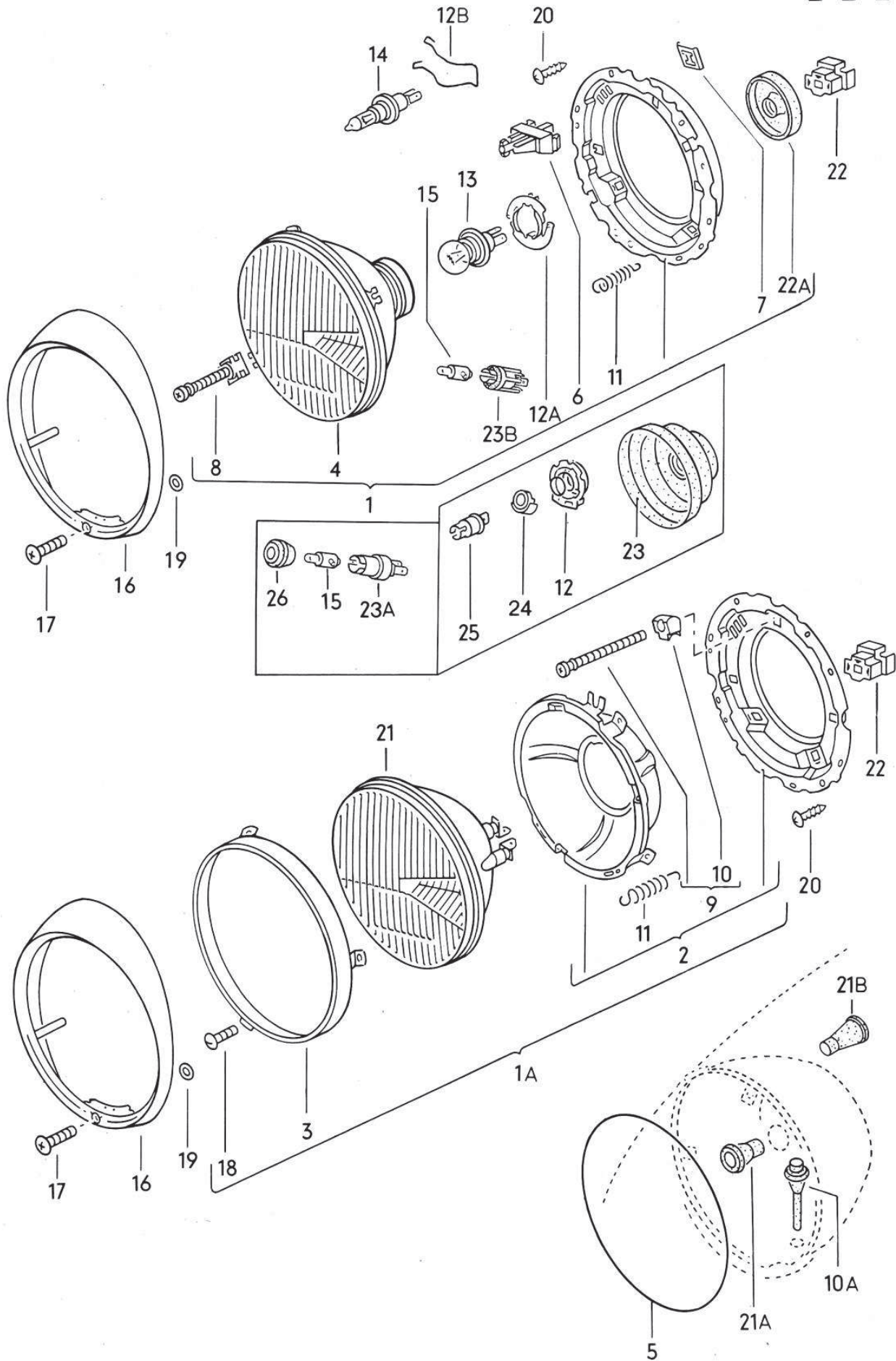

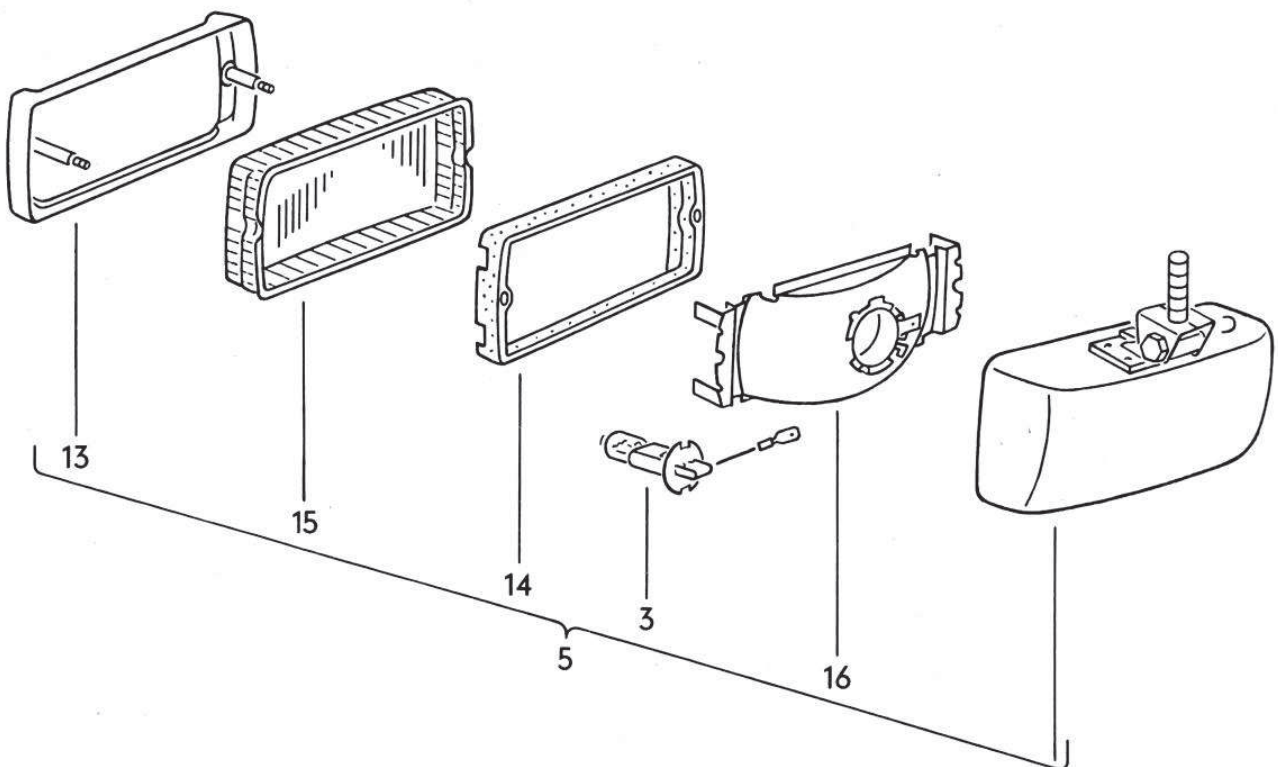
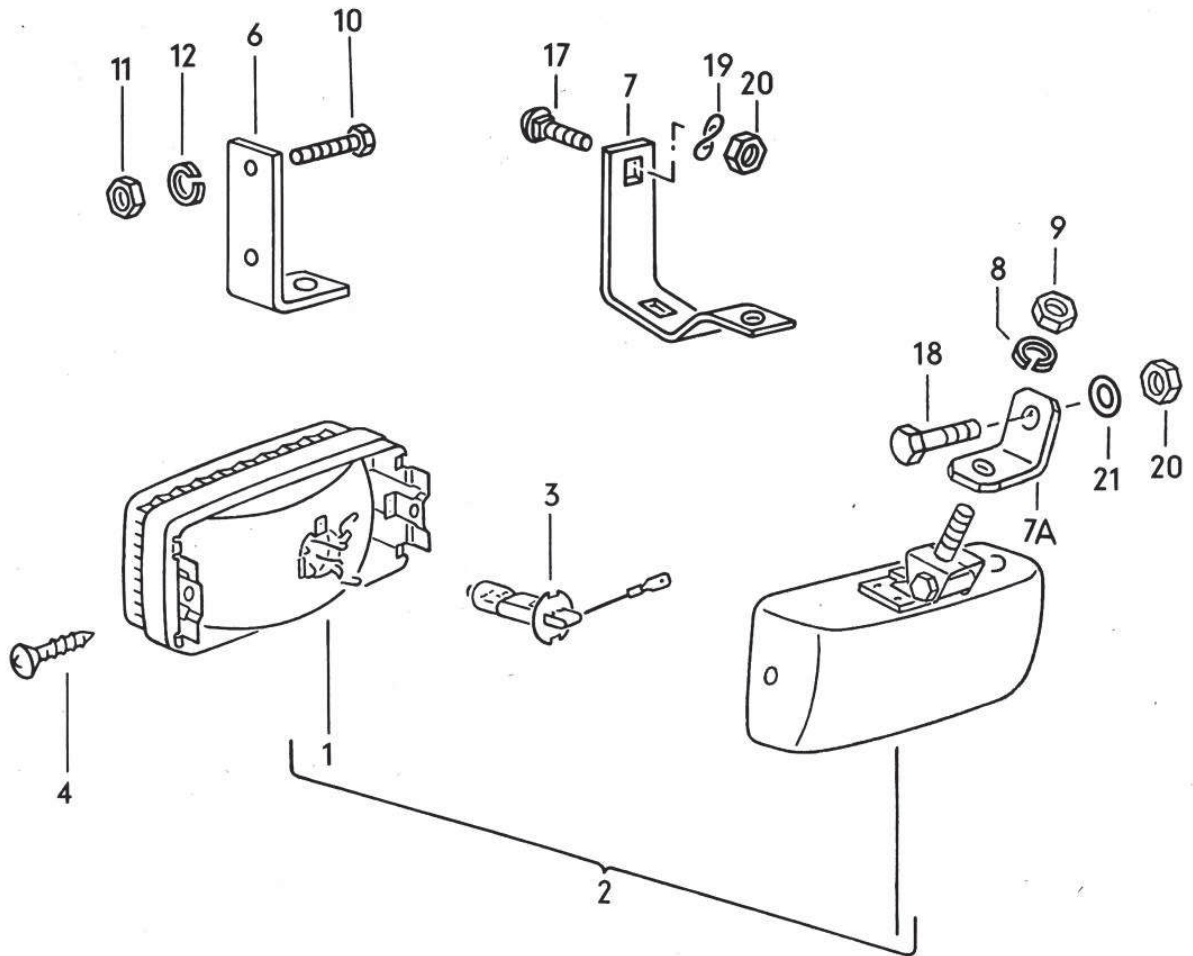

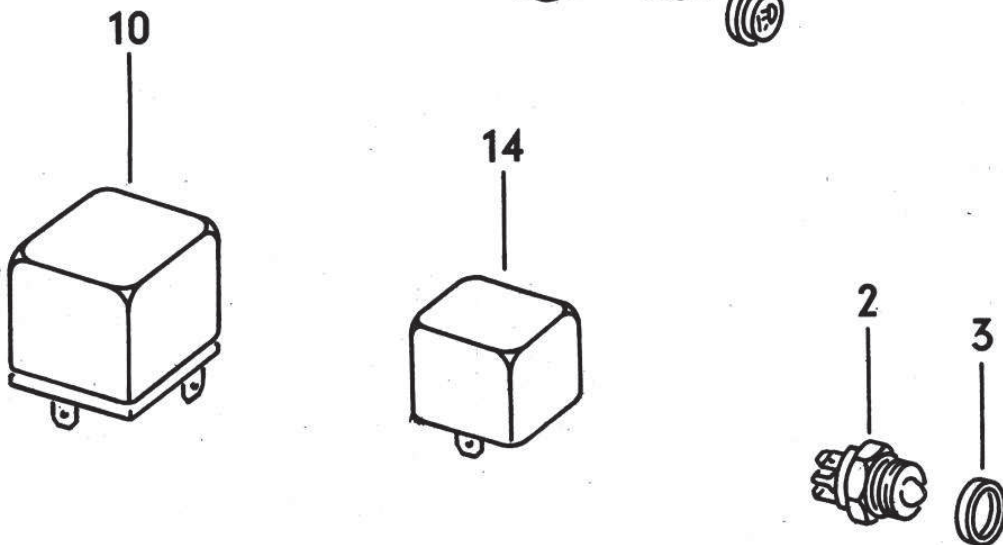
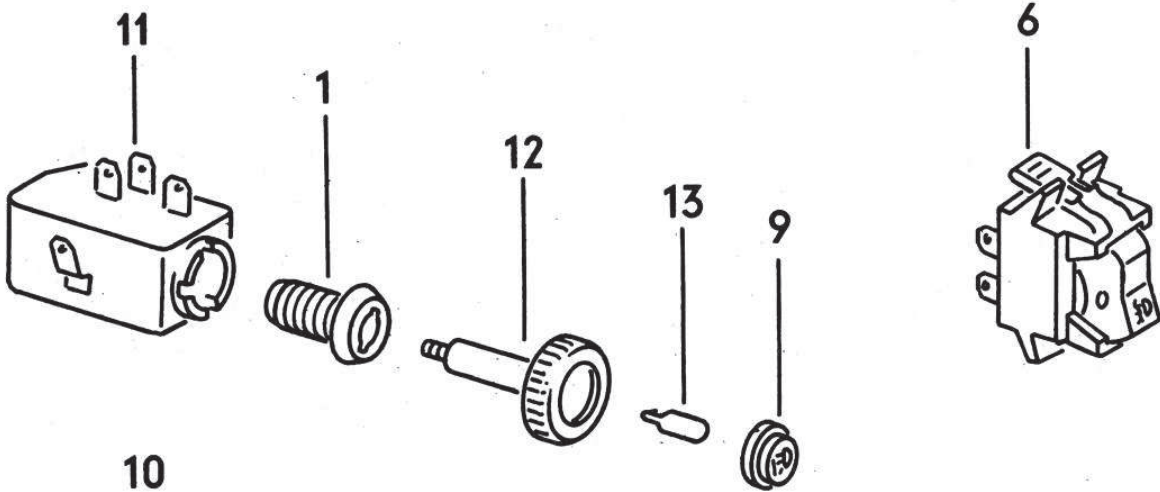
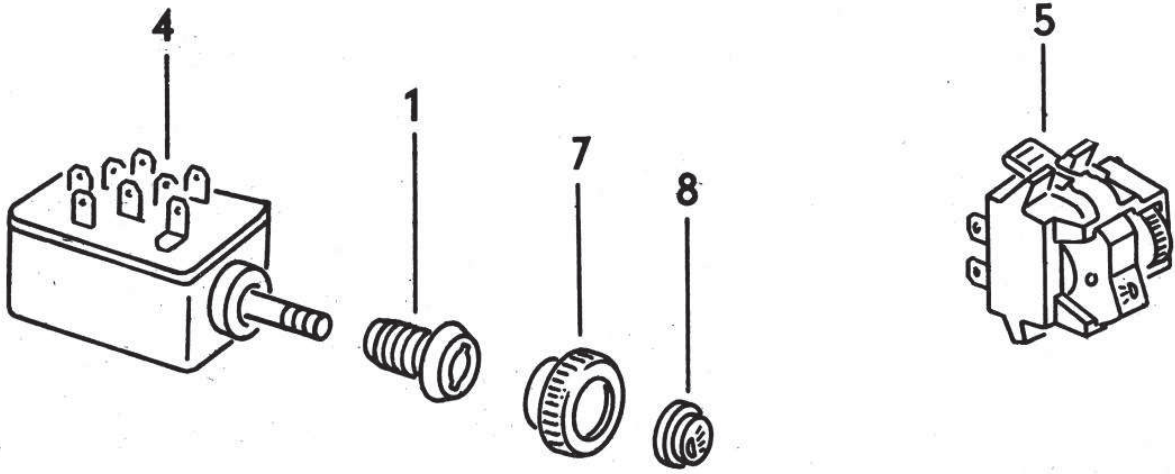

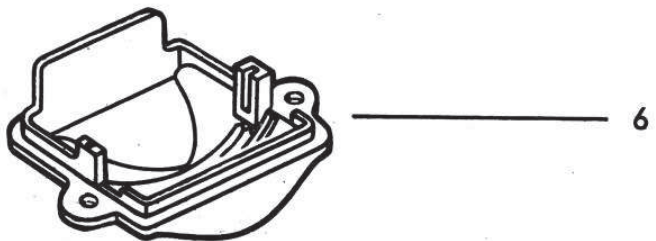
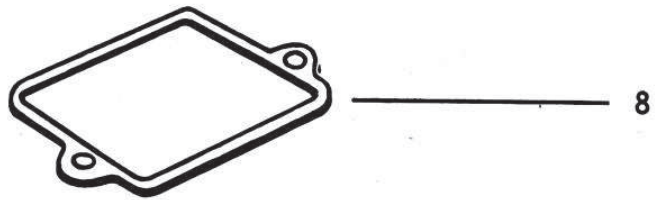
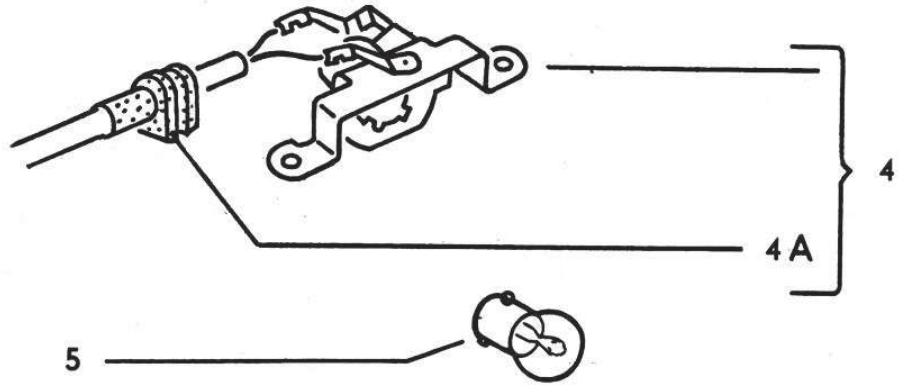
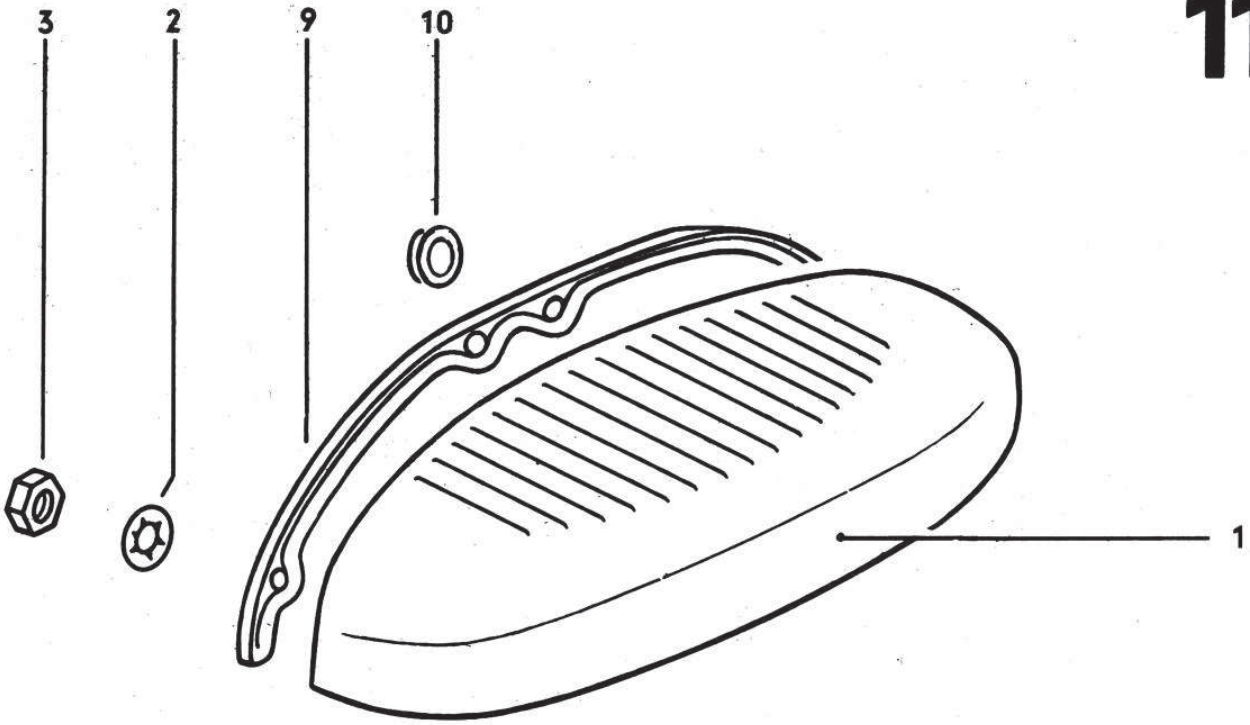

114-10

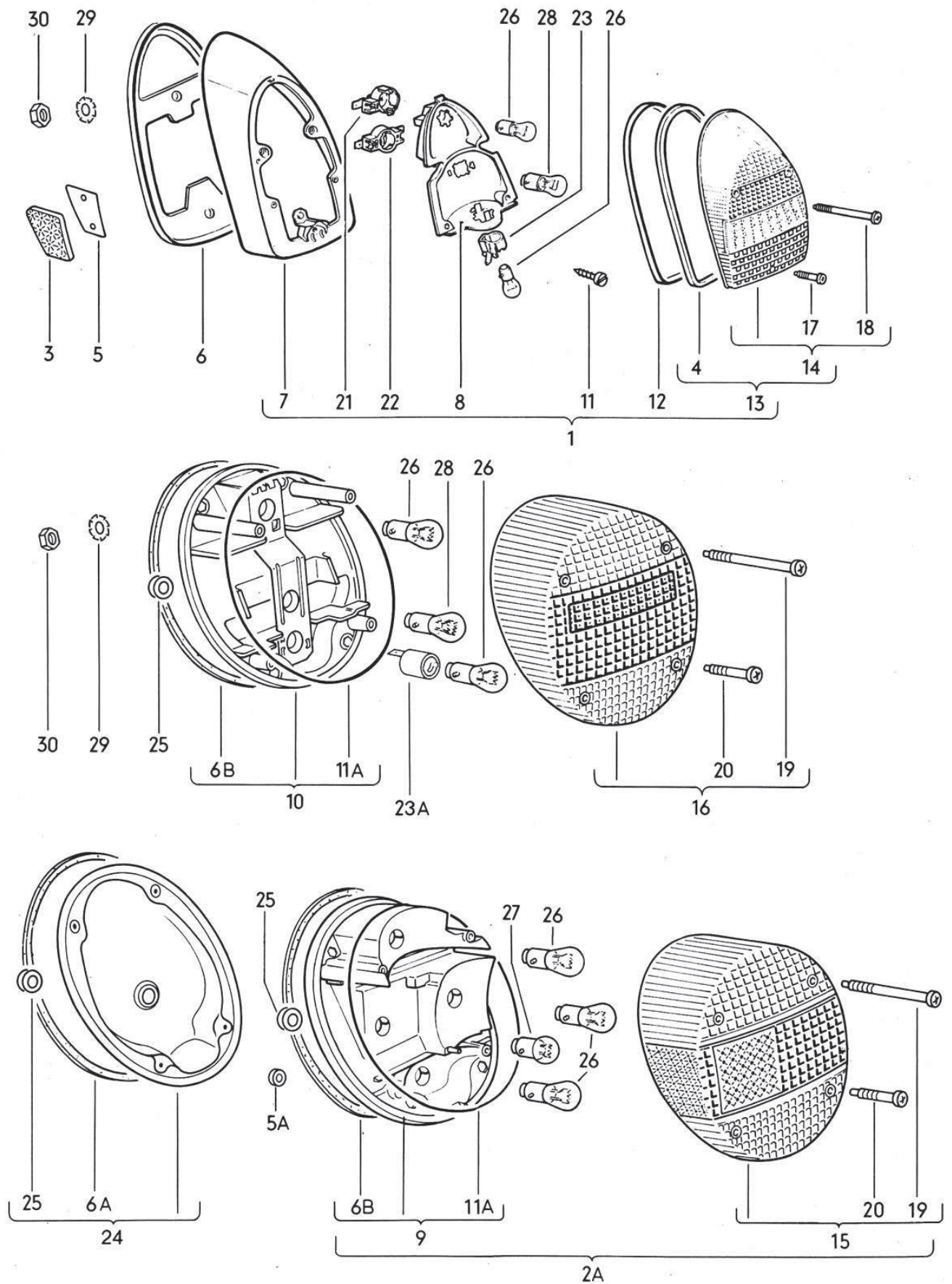

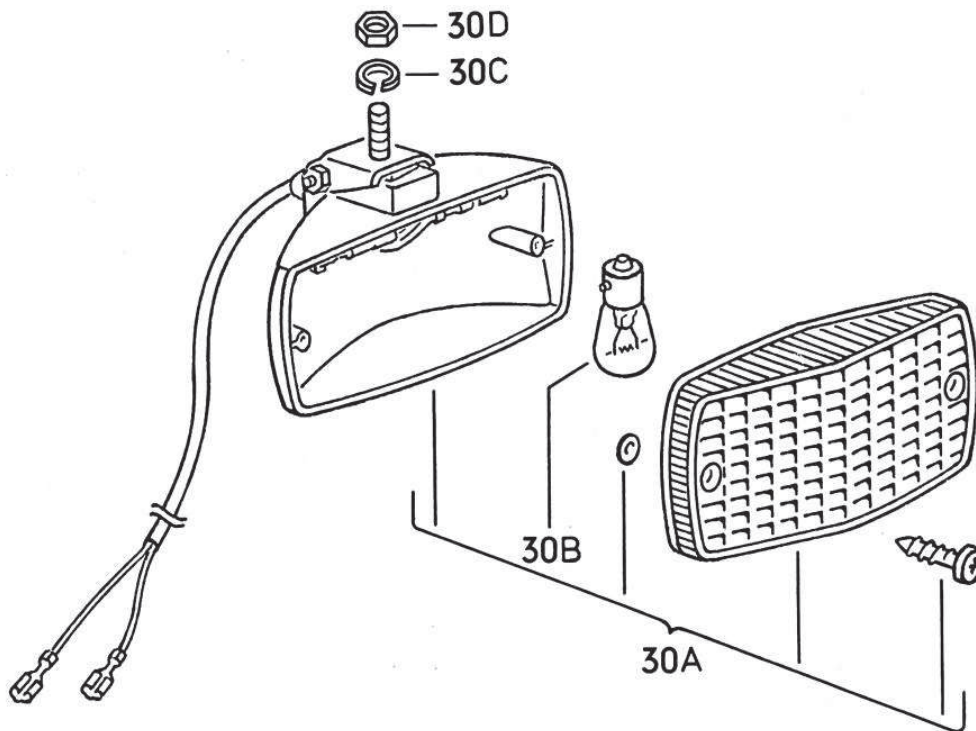
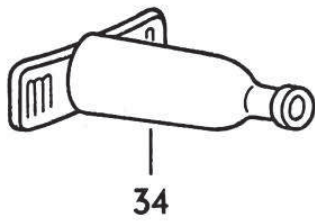

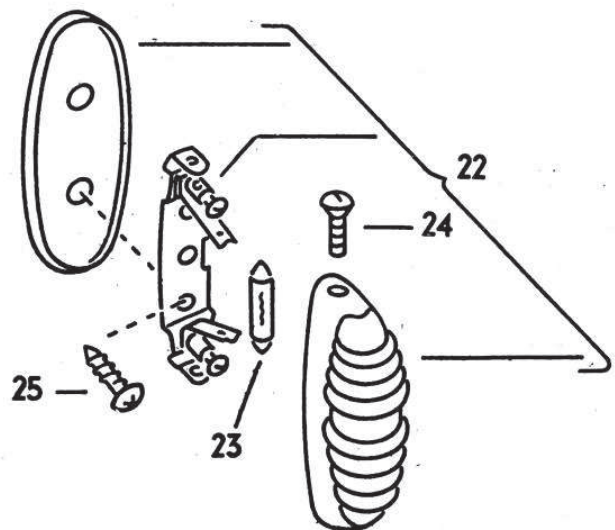
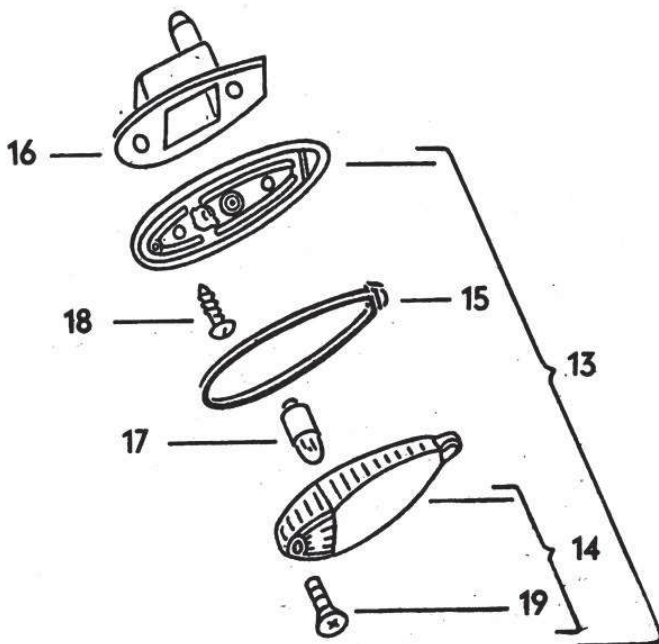
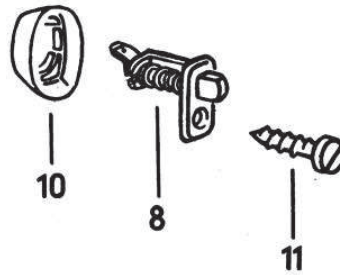
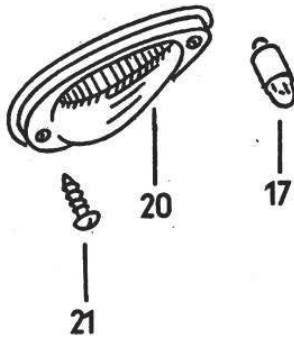
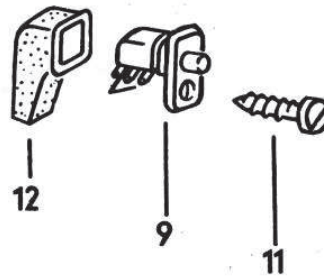
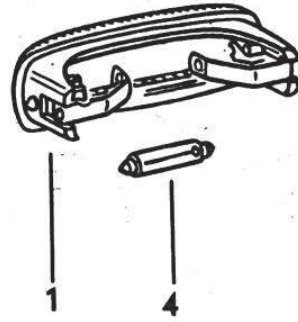
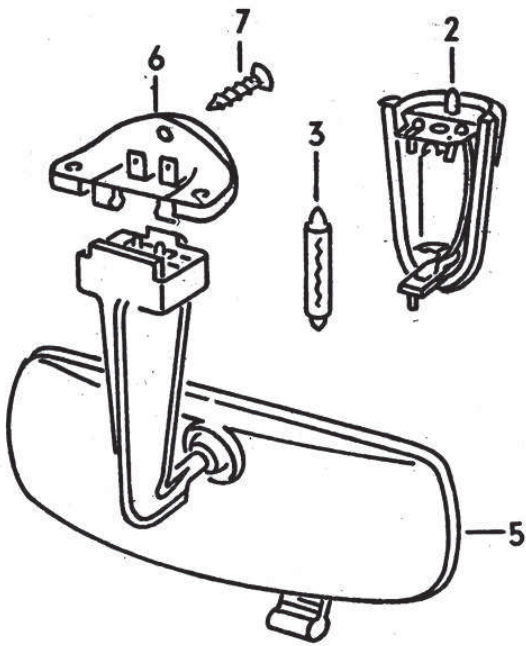

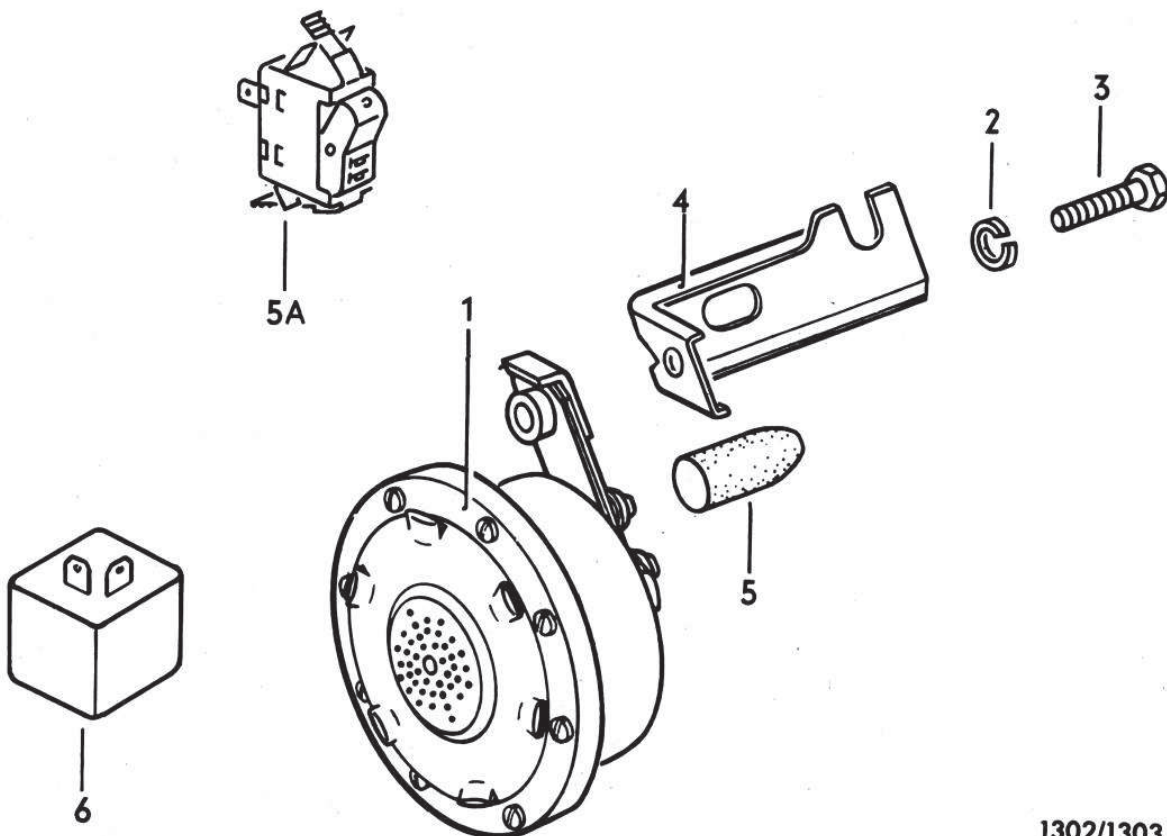
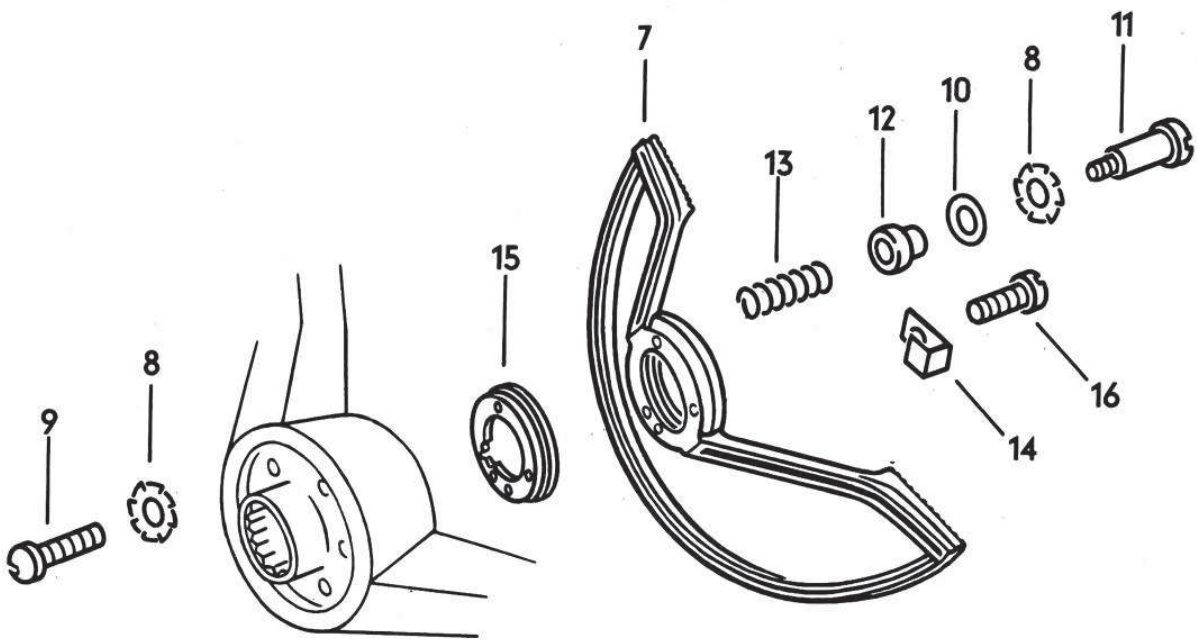

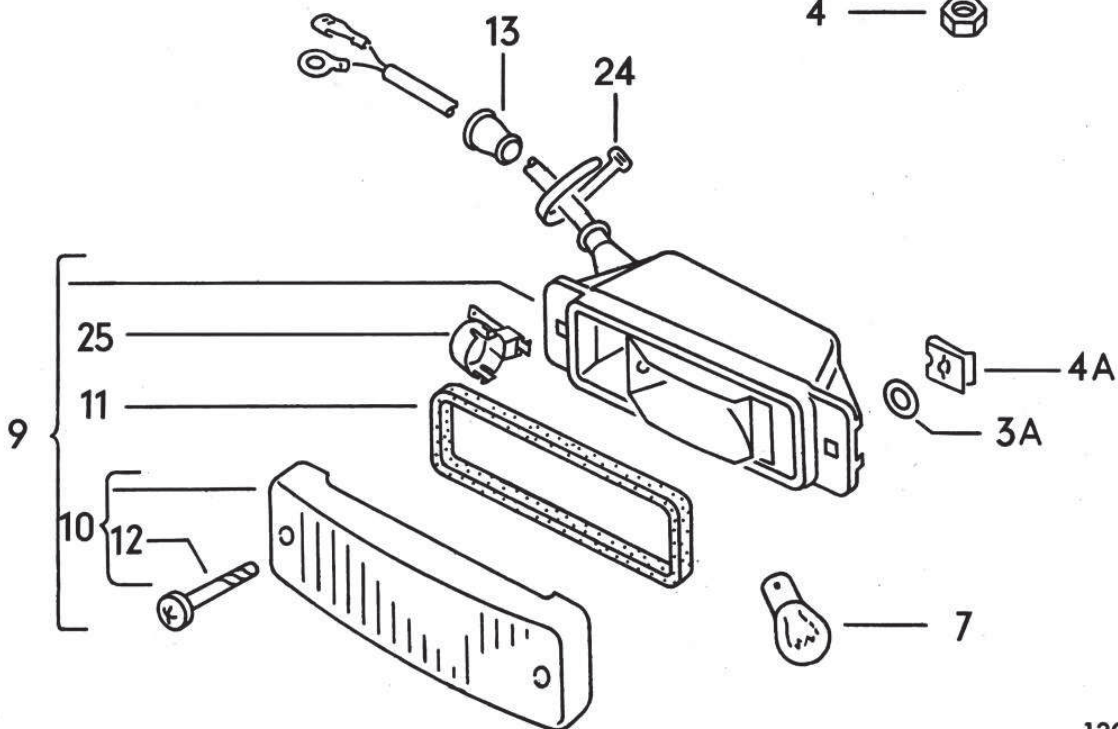
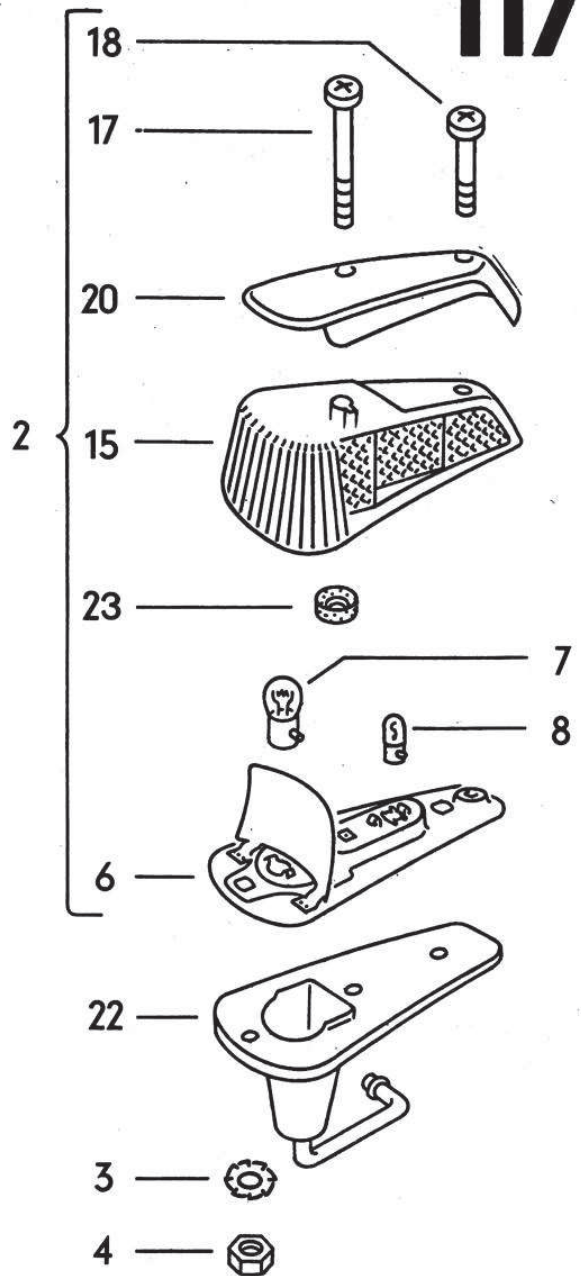
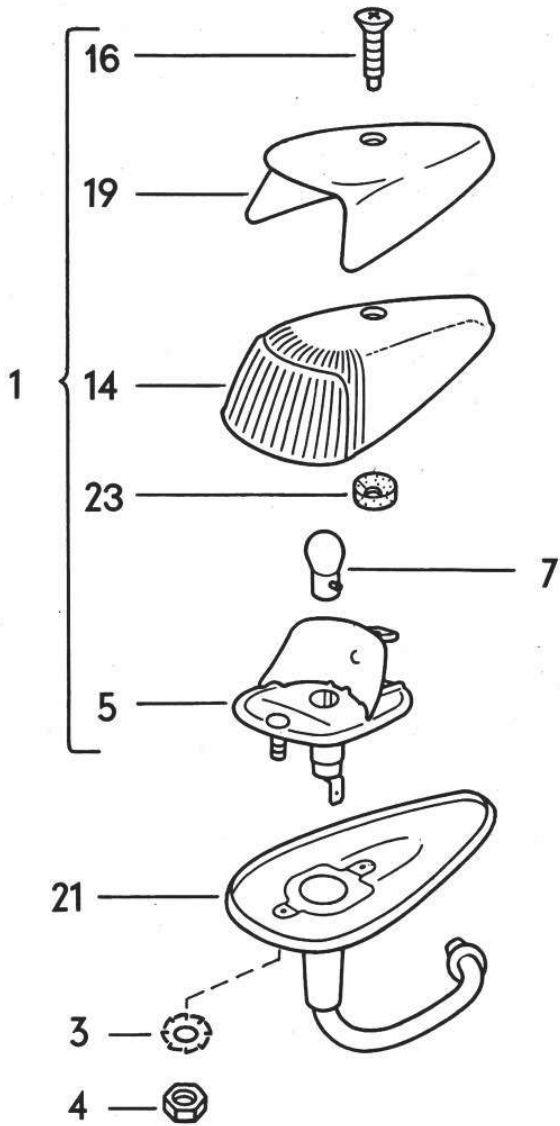

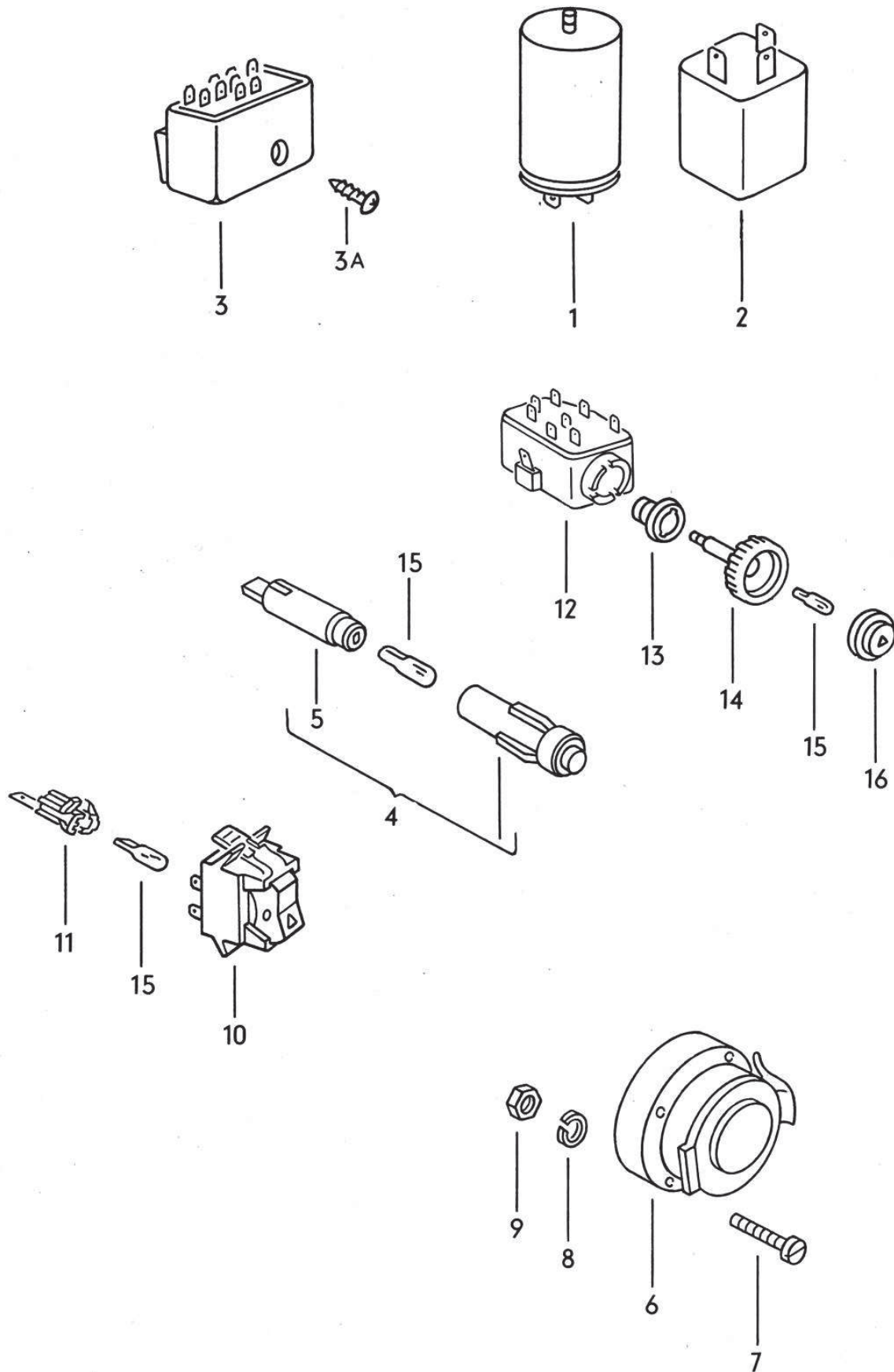

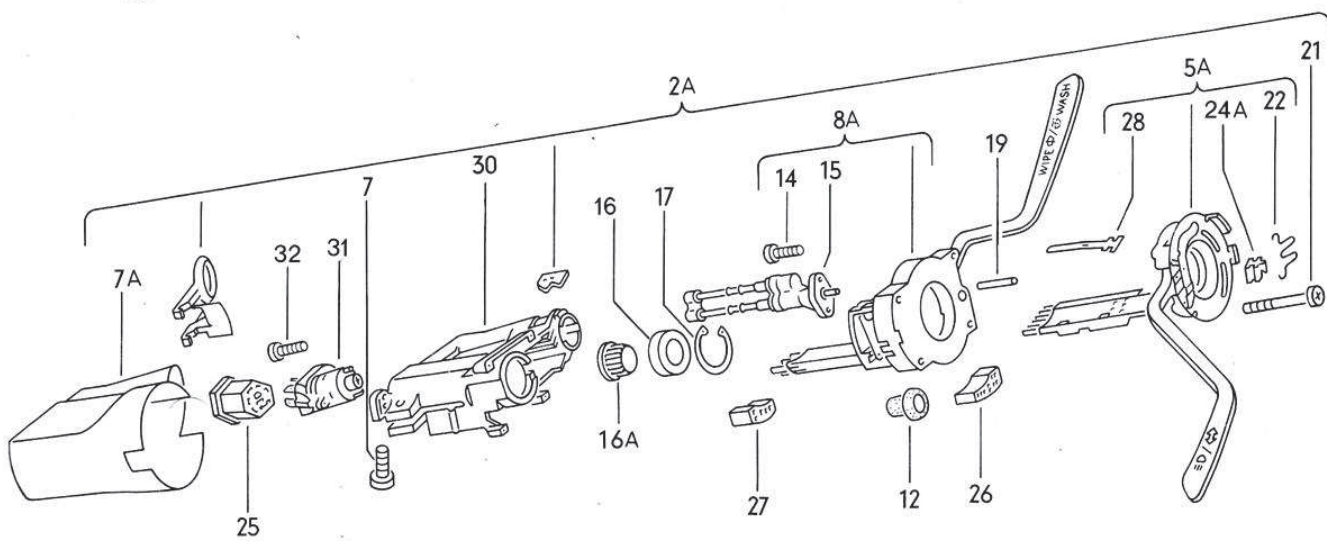
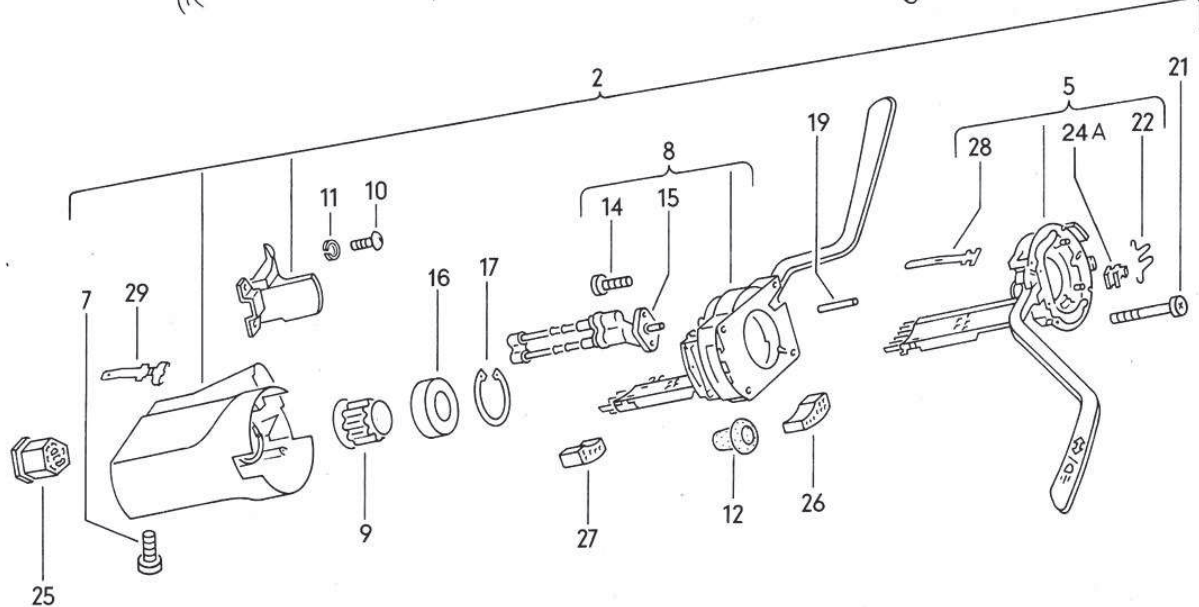
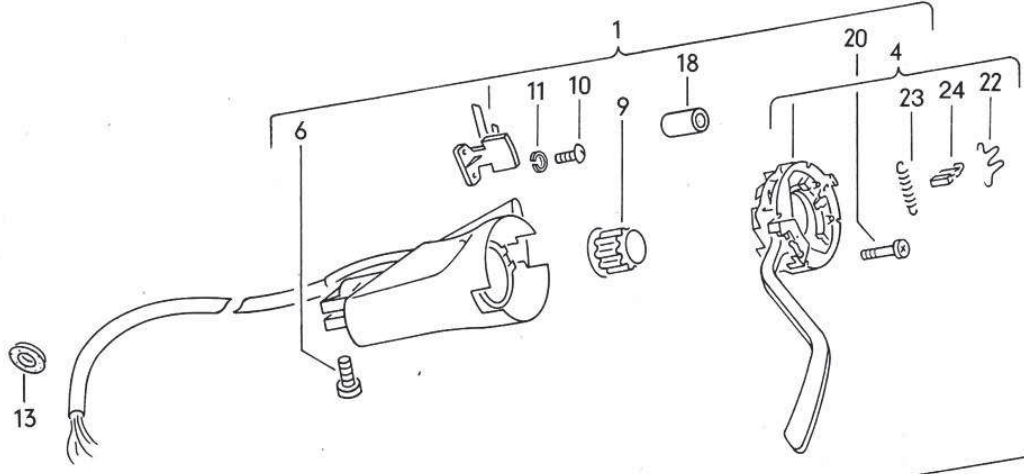

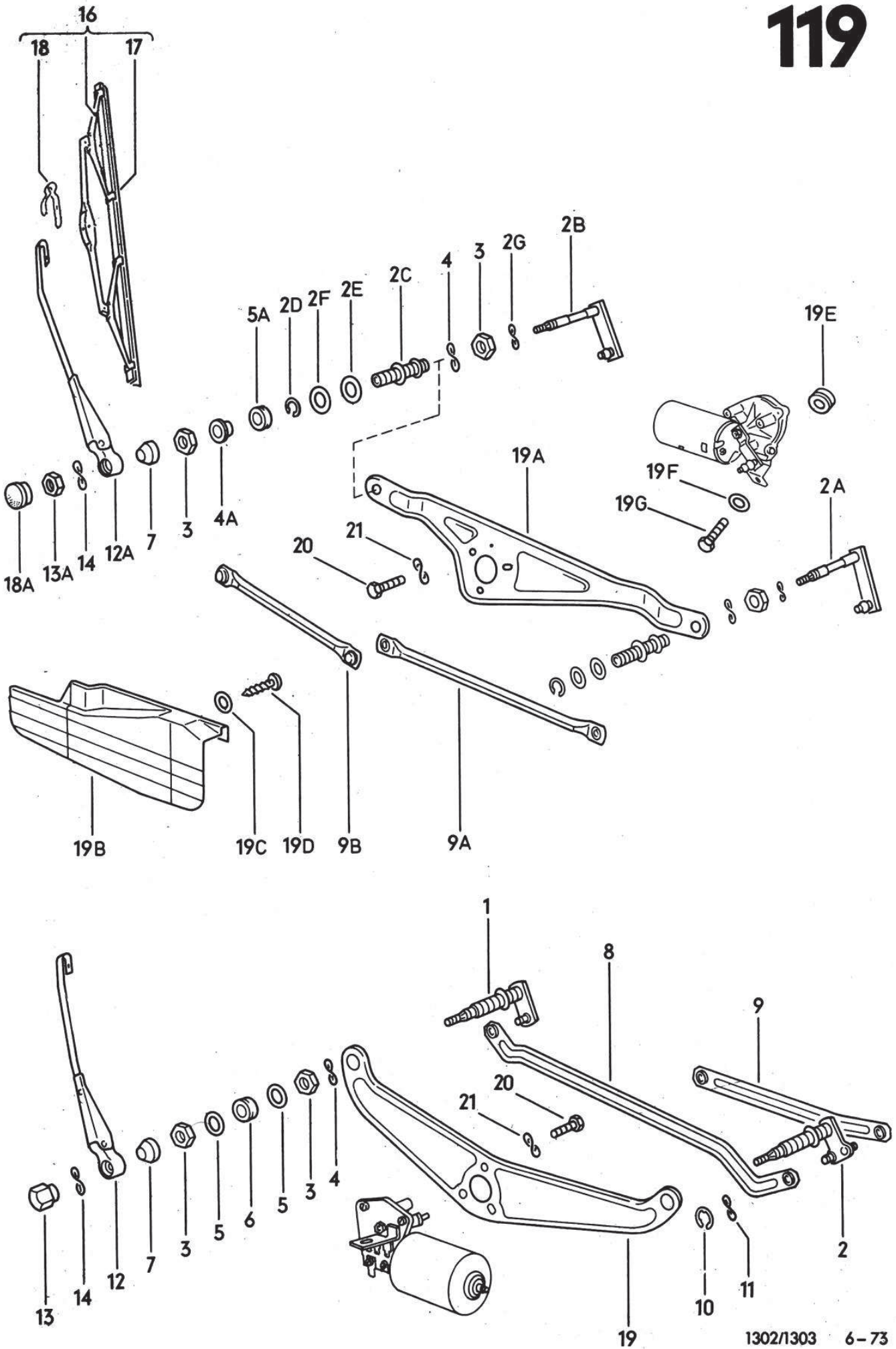

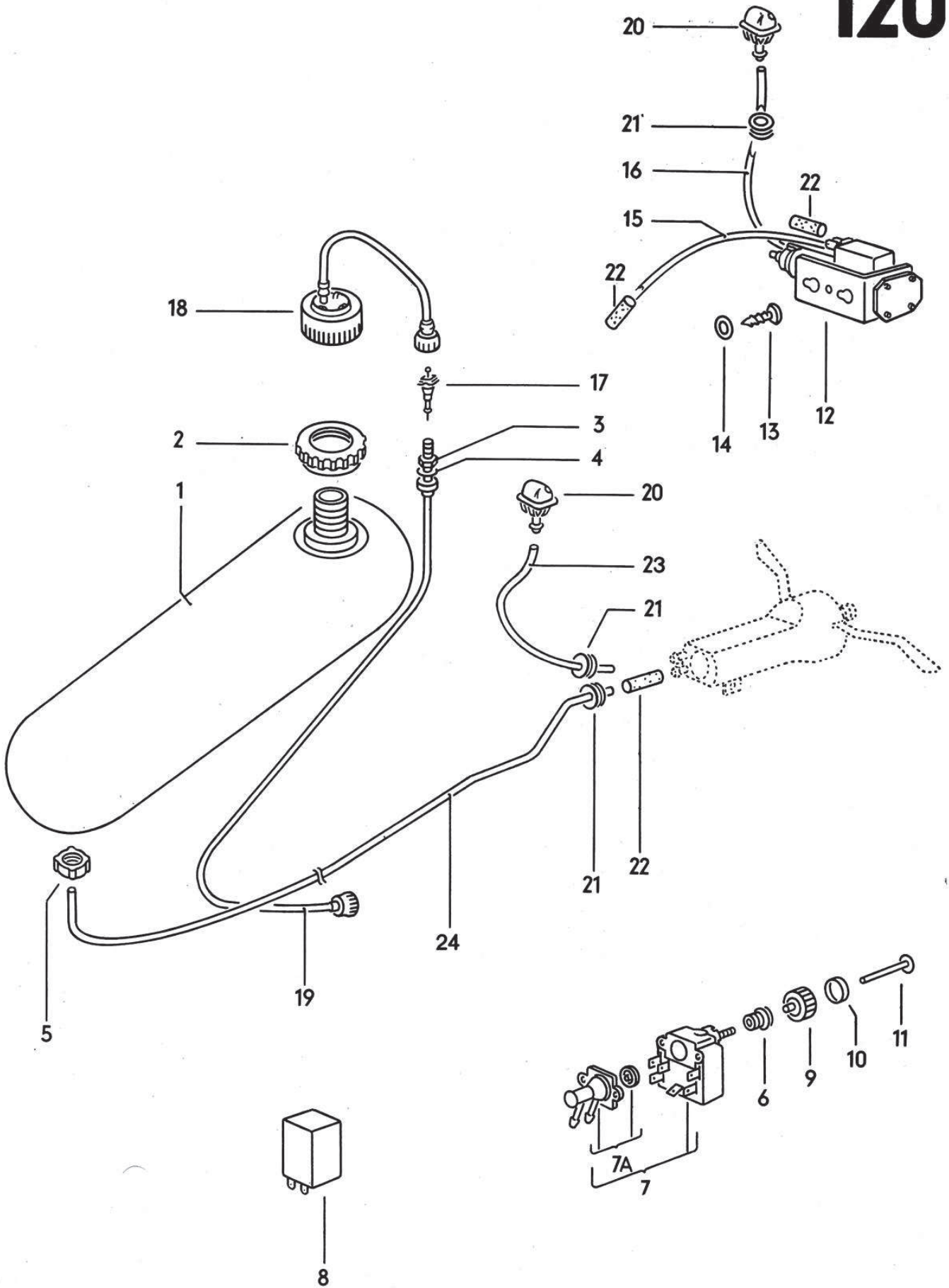

120-10

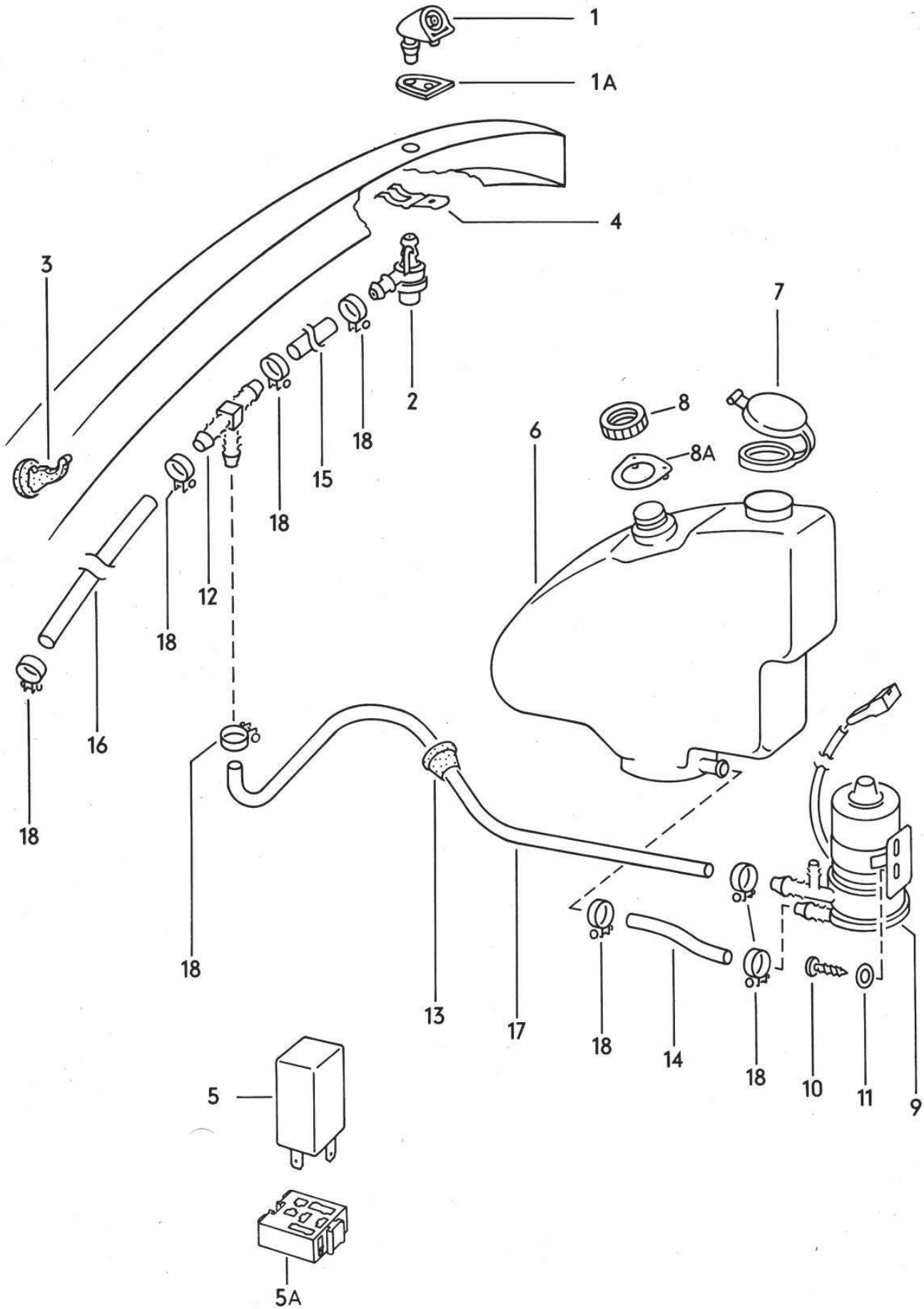

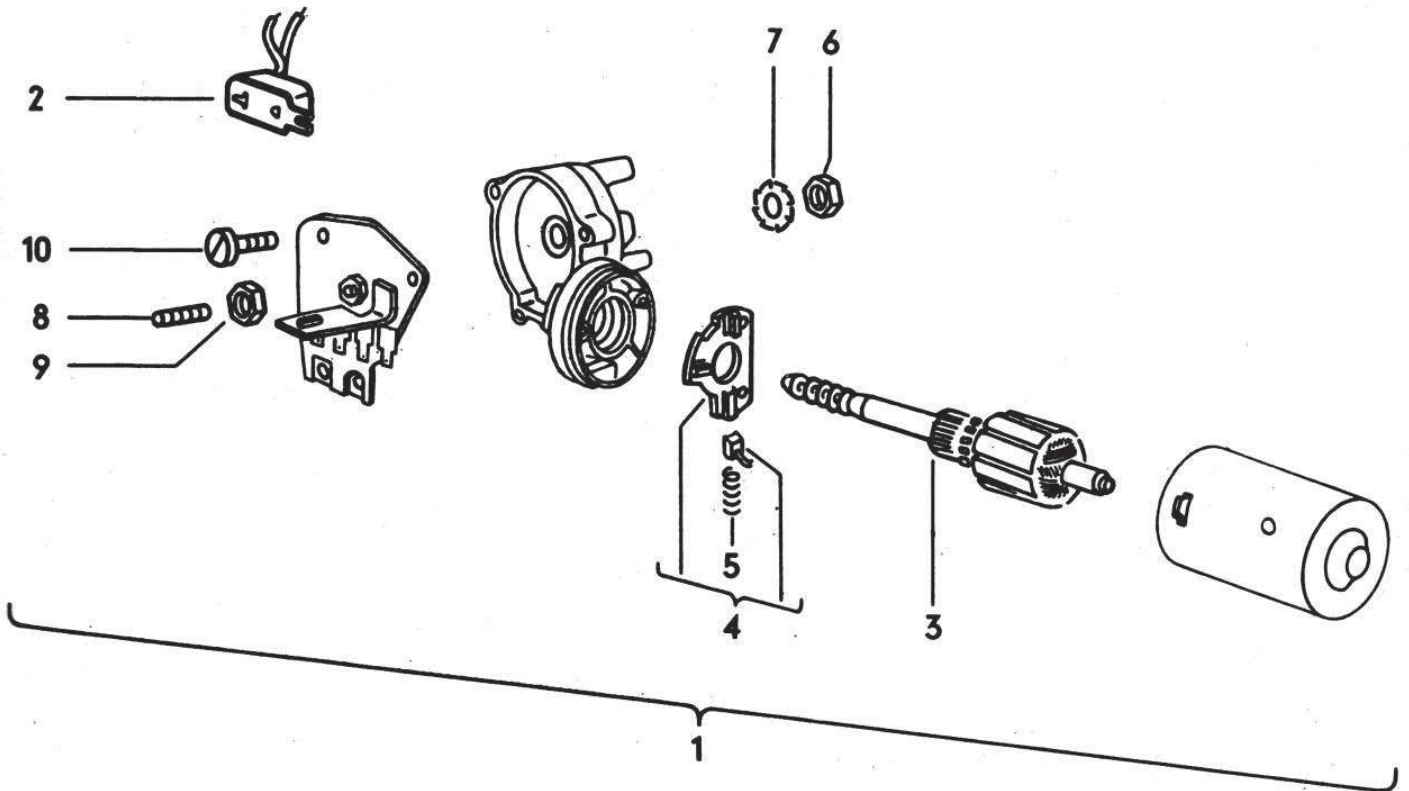

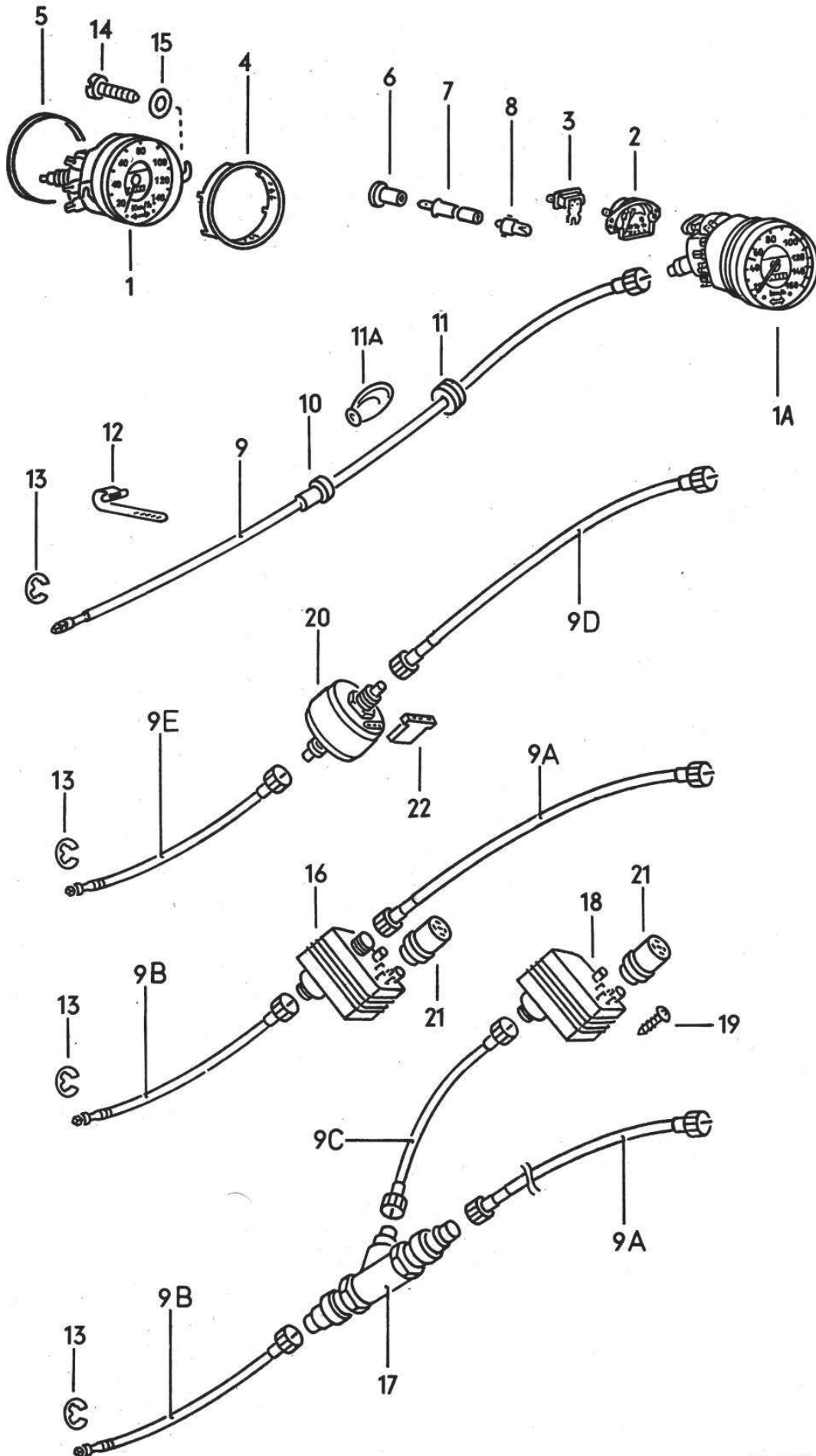

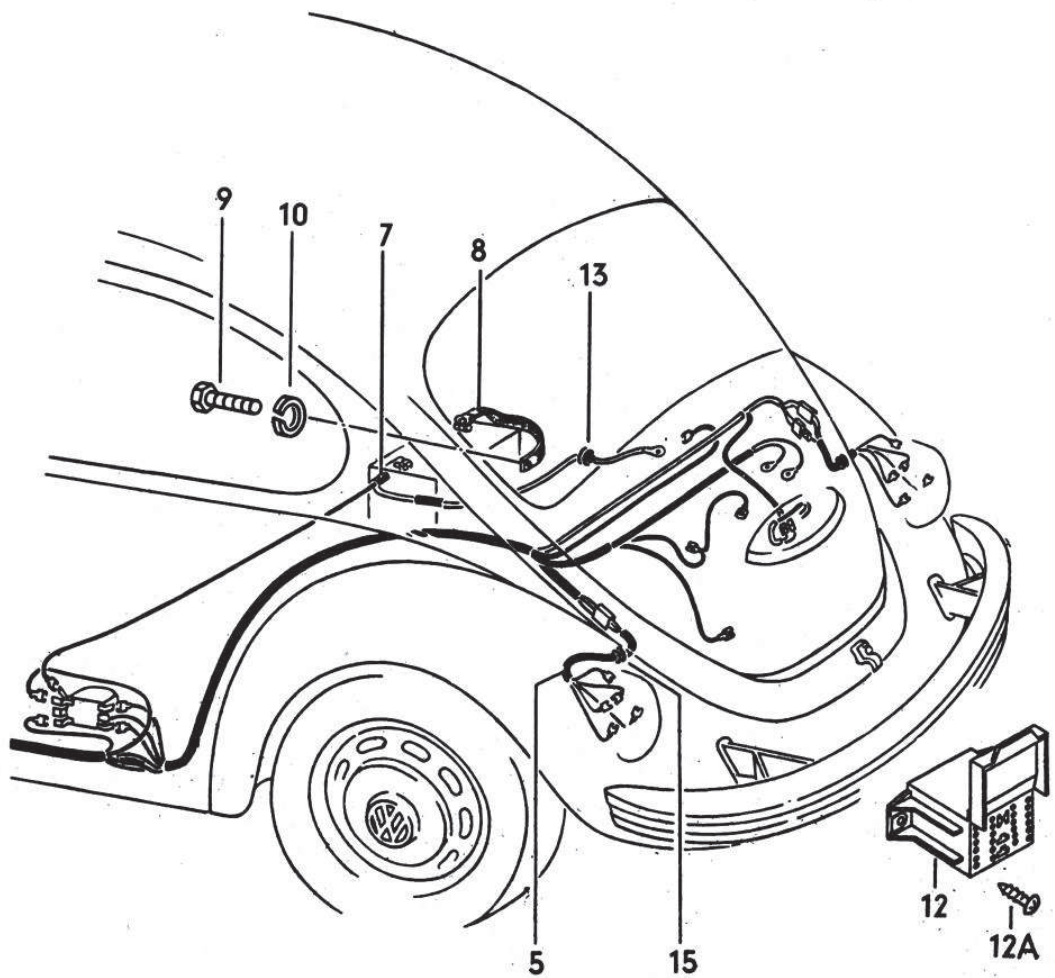
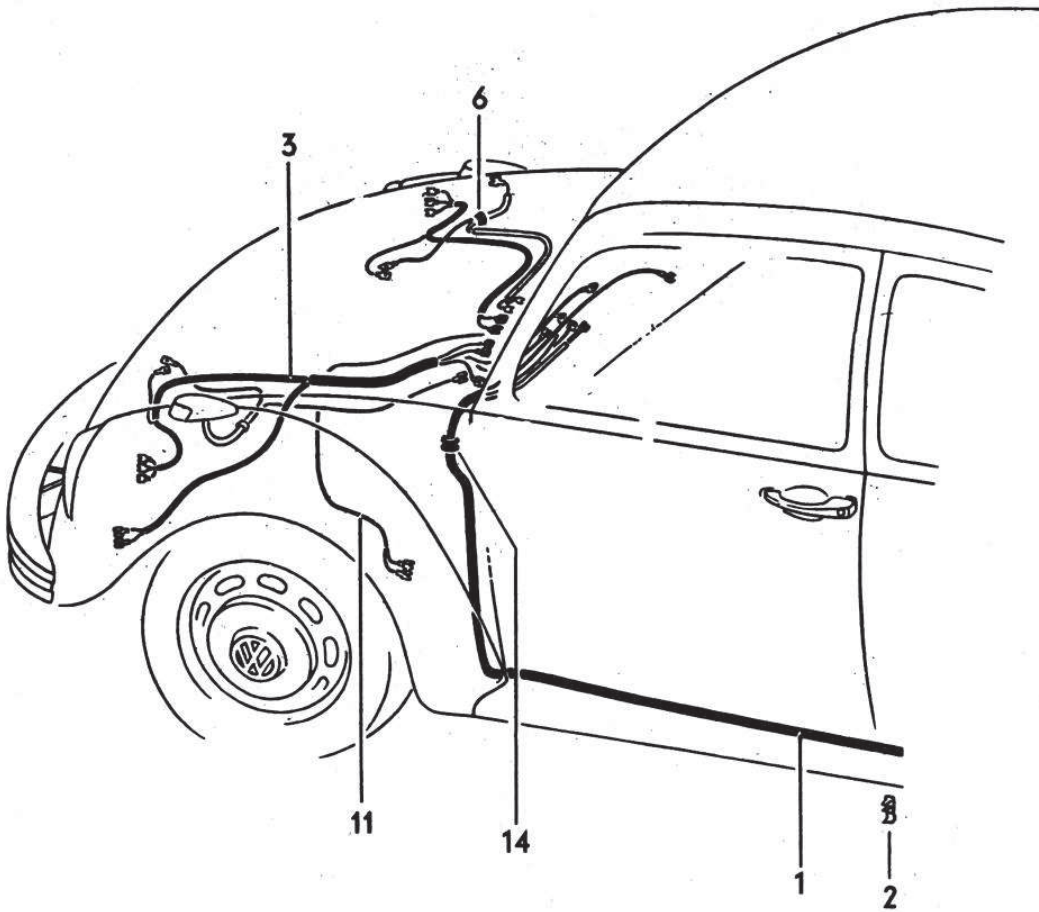



1

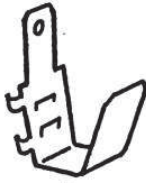

2



3



4



5



6



7



8



9



10



11



12



13



14



15



16

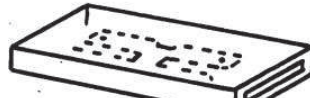

17

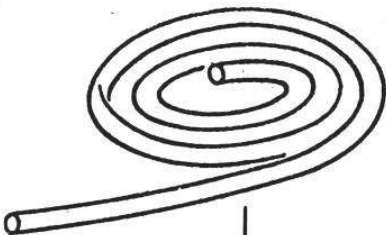

18

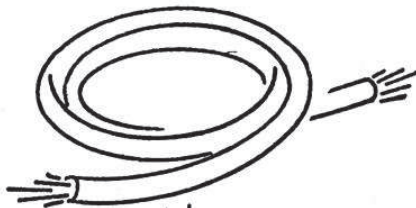

19

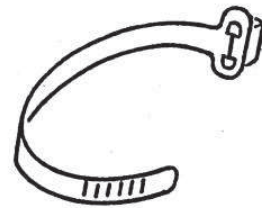

20

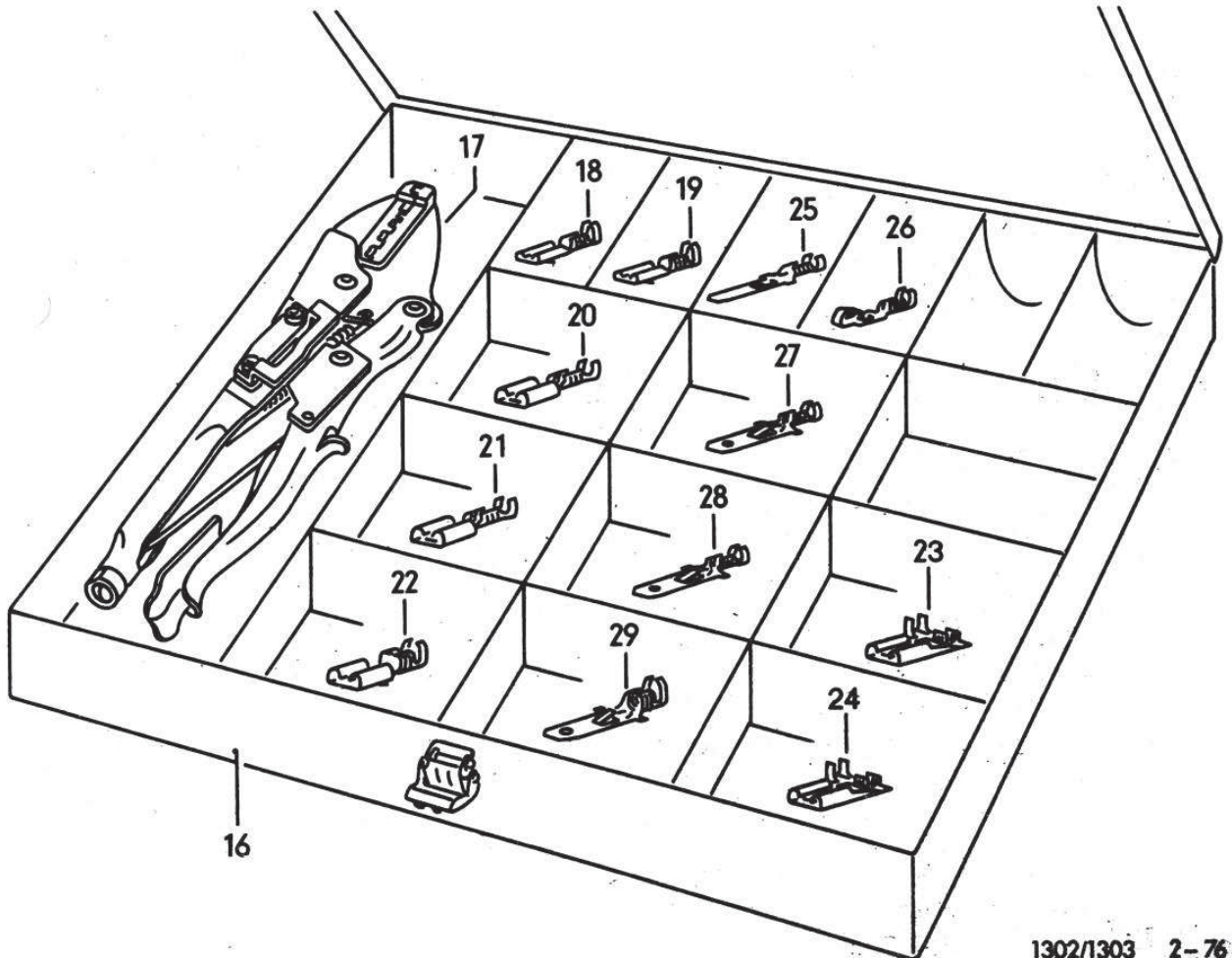
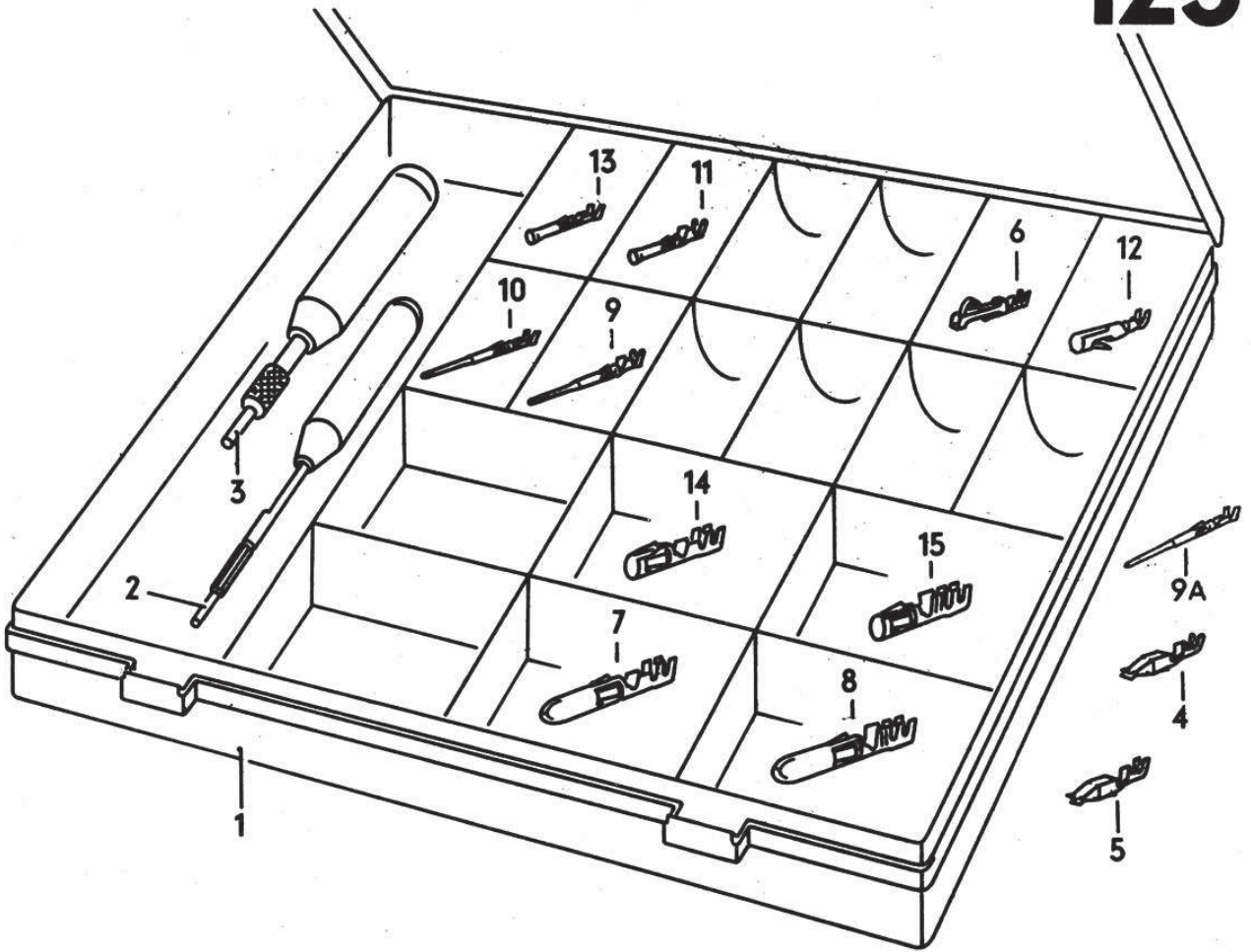

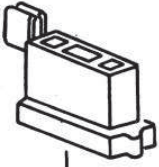

1

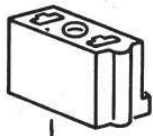

2



2A



3



4

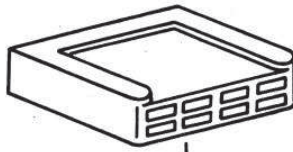

5

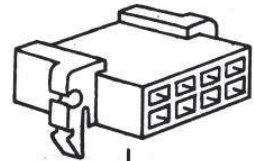

6

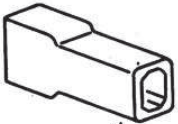

7



9



8



8A

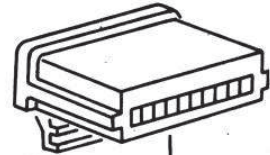

10

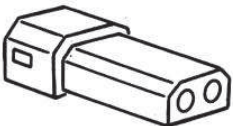

11

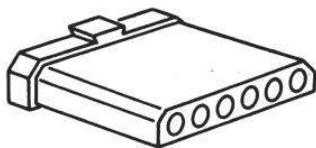

12

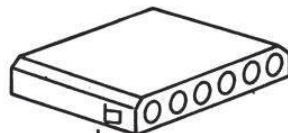

13

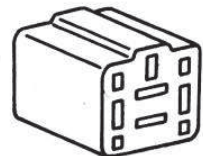

14

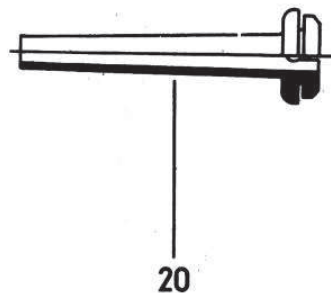
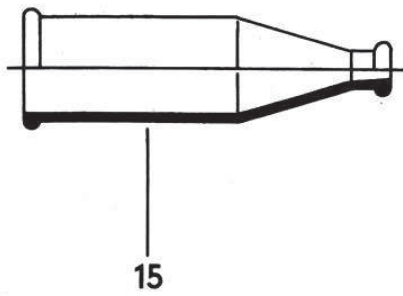
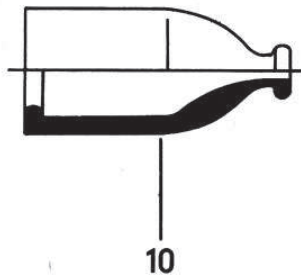

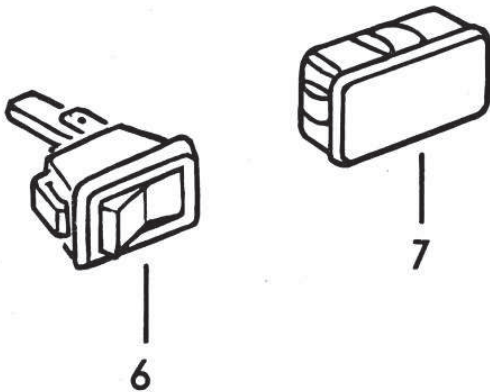
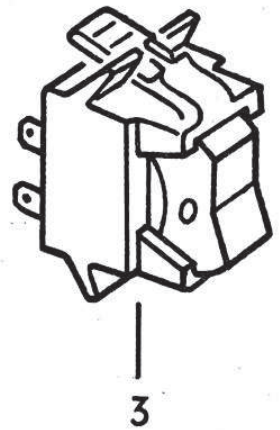
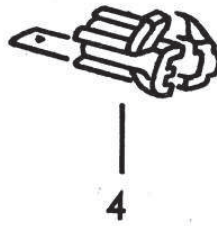
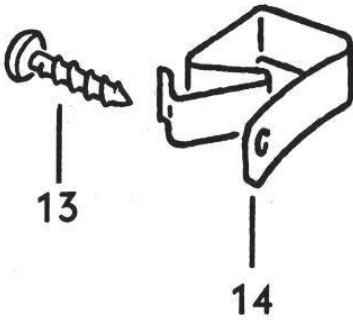
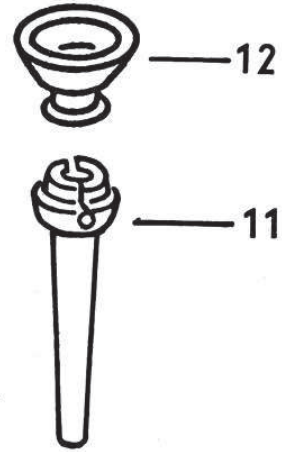
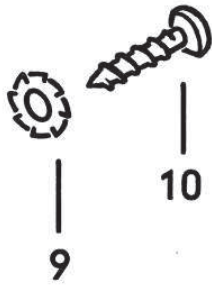
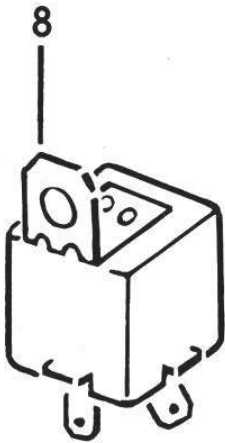

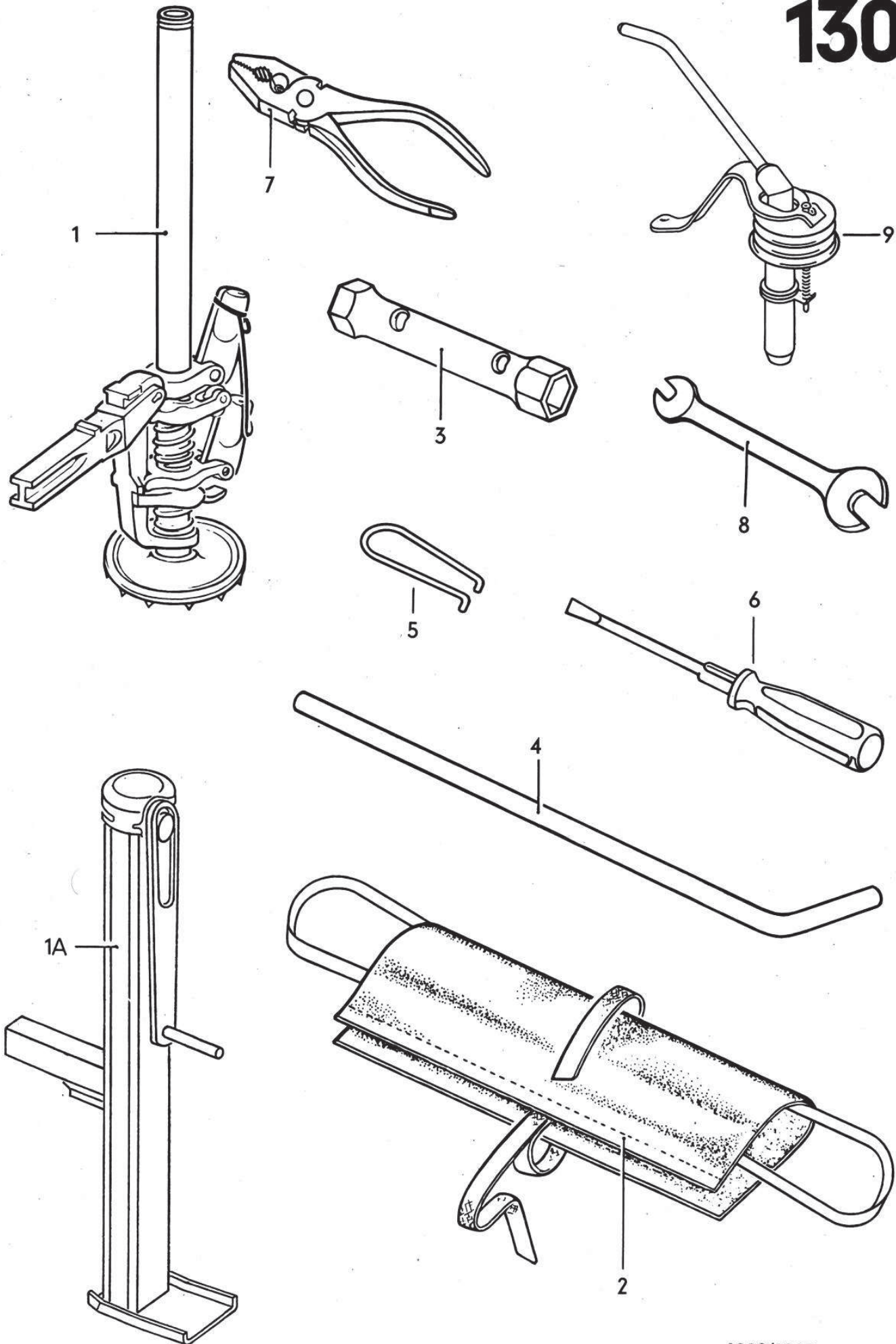

Ihr V.A.G Partner:/Your V.A.G dealer:/Votre agent
V.A.G:/Il Suo partner V.A.G:/Su concesionario V.A.G:/
uw V.A.G dealer:

Superbeetles.nl
VWkever.com



000.7340.81.89

Nachdruck, auch auszugsweise, nur mit besonderer Genehmigung
des Zentralbereichs Ersatzteile der Volkswagenwerk AG
gestattet.

May not be reproduced in whole or in part without the express
consent of the Central Parts Division of the Volkswagenwerk AG.

Reproduction, même partielle, interdite sans l'autorisation
expresse de la Division Pièces de Rechange de la
Volkswagenwerk AG.

Riproduzione, anche parziale, vietata senza speciale autorizzazione
del Settore centrale Servizio ricambi della Volkswagenwerk AG.

Cualquier réimpresión, aunque sea en extracto, sólo podrá
hacerse bajo la especial autorización de la Division
Central de Repuestos de la Volkswagenwerk AG.

Nadruk, ook gedeeltelijk, alleen toegestaan met speciale
goedkeuring van het Centrale Onderdelenmagazijn van de
Volkswagenfabriek.

Printed in Germany 12/1983.